

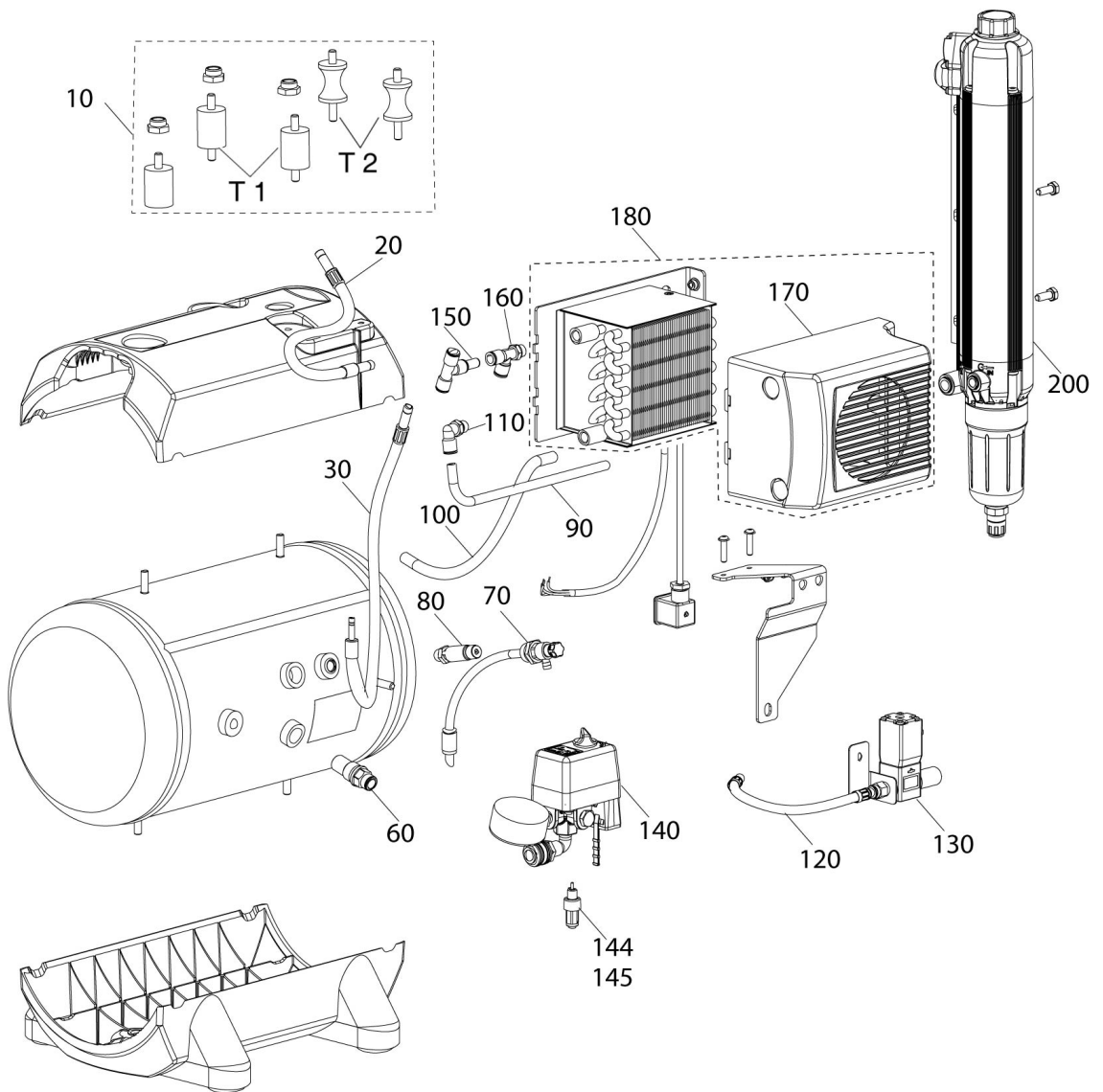

Item no.	Description	Order-No.
10	fan cover	5280-120-07
20	fan blade	5280-120-06
30	Air guide 2 cyl.	5280-120-05
31	Air guide 1 cyl.	5180-120-05
40	Capacitor 25 μ F	9000-104-93
41	Capacitor 20 μ F	9000-104-91
50	Cylinder	5180-110-00E
60	Sleeve	5180-981-00
70	Piston	5180-140-00E
80	Insert for intake filter	5180-982-00
90	Filter cover	5180-100-07E
160	Crankcase housing cover	5180-100-10
200	Compressor unit Tornado 1, 230 V	5180-100-50E
201	Compressor unit Tornado 2, 230 V	5280-100-50E

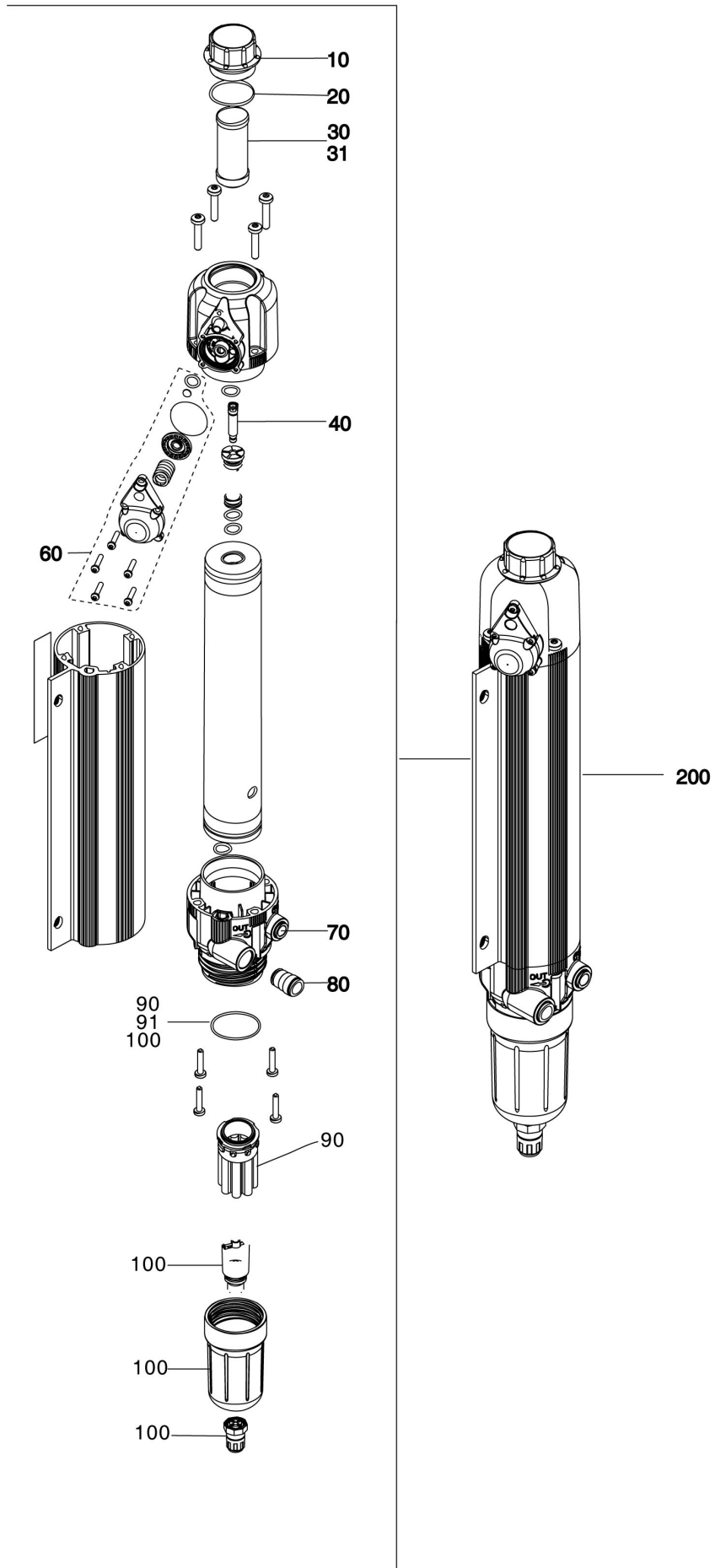

Item no.	Description	Order-No.
10	Shock absorber set	5180-982-50
20	Pressure hose	5180-002-00
20	Pressure hose 390 mm D=10 plug	4252-001-00
30	Pressure hose 460 mm	5272-001-00
60	Non return valve	5150-041-00
70	Cut Off Valve R1/4"	5150-008-50
80	Safety Valve R 1/4 0-10 Bar	9000-326-11
90	hose 6 x 2 x 10	9000-317-25
100	hose 8x2x12	9000-317-47
110	L Joint	9000-310-020
120	Pressure hose 390 mm D=10 plug	4252-001-00
130	Solenoid valve	9000-303-87
140	Pressure switch	5180-011-00E
144	Relief valve with brown ram installed until December 2011	9000-301-77
145	Relief valve with black ram installed from December 2011	9000-301-73
150	Shaped joint 10 mm, double plug	9000-313-01
160	T-Joint	9000-310-016
170	Cooler cover	5180-300-01
180	Cooling element	5180-310-50E
200	Membran Dryer	1650-980-00



Item no.	Description	Order-No.
10	Cover screw	1610-100-02
20	O-Ring 38 x 2.5	9000-401-21
30	Fine Filter for Dry Air System	1610-121-00
31	Sterile Filter for Dry Air System	1640-981-00
40	Jet set	1650-981-00
60	Upperpart membranecover	1650-983-00
70	Quick coupling M10	9000-310-083
80	Quick coupling M12	9000-310-084
90	Sinter Filter for Membrane Drying Unit	1650-101-00
91	O-ring	9000-401-62
100	Condensate drain	1650-982-00
200	Membran Dryer	1650-980-00