

CASTELLINI S.p.A.
Via Saliceto, 22
40013 CASTEL MAGGIORE
BOLOGNA (ITALY)
Tel (int. code) + 051700877
Fax (int. code) + 051701056
E mail: castellini@castellini.com

INSTRUCTIONS USE AND MAINTENANCE HANDBOOK

INSTRUCTIONS FOR THE INSTALLATION

Puma Evo

family

Medical Device for Dentistry

385 . 2E . L06

Summary

| | Page |
|---|-------------|
| Part I - Instructions use and maintenance handbook | 3 |
| Important notice | 4 |
| Setting-up procedures | 5 |
| Maintenance and revisions | 7 |
| Informations about conformity by "Puma Evo" dental equipment at CEI EN 60601-1-2 Norms - 2001 Edition | 8 |
| Technical data equipment | 10 |
| Unit identification label | 11 |
| Medical devices applies to the unit - Unit operations..... | 13 |
| Pictures and descriptions | 14 |
| Foot control functions..... | 19 |
| Chair movements | 20 |
| Autosteril/Time Flushing System..... | 22 |
| Separate supply system | 24 |
| Suction systems (<i>optional</i>)..... | 25 |
| Conversion of the "Puma Evo" unit from right-handed to left-handed configuration (<i>only for ambidextrous dental units</i>)..... | 26 |
| Disinfection and sterilization | 27 |
| Equipment sanitization schedule | 29 |
| Routine maintenance | 30 |
| Routine maintenance program..... | 33 |
| Products to be used with the Castellini dental unit | 34 |
| Part II – Operating lamp "Luna"..... | 35 |
| Technical data..... | 36 |
| Pictures and descriptions - Replacement of the bulb..... | 37 |
| Focusing of the "Luna" operating light - Cleaning of the optical parts - Pantograph arm regulation | 38 |
| Overall dimensions | 39 |
| Part III – Operating instruments | 40 |
| "Threesteril" Syringe..... | 41 |
| "Multisteril 2 Titanium" Syringe..... | 43 |
| "Cleanair 2000" - "Cleanlight 2000" Turbine | 45 |
| "Hi-Power 2 Ceramic" – "Titanium Gold 2" - "Titanium Gold 2 Miniature" Turbine | 49 |
| "Implantor 2" and " Implantor 2L" Micromotor..... | 53 |
| "Piezosteril 5" - "Piezolight 5" Scaler handpiece | 56 |
| "Leda" Polymerizing Lamp..... | 59 |
| Part IV – Instructions for the installation | 61 |
| Essential requirements..... | 62 |
| Permitted environmental conditions for transport and storage..... | 63 |
| Installing the chair and the unit..... | 64 |
| Installing the right-hand unit..... | 67 |
| Installing the dental unit (<i>only ambidextrous units</i>)..... | 68 |
| Installing the scialytic lamp post(<i>only ambidextrous units</i>)..... | 77 |
| Installing the scialytic lamp post and levelling (<i>model for right-hand dental unit</i>)..... | 78 |
| Safety covers | 79 |
| Replacing the lamp of the negatoscope for intraoral X-Rays..... | 82 |
| Adjusting the tension of the levers on the instrument tray model S.P.R.I..... | 83 |
| Adjusting the working pressures | 84 |
| Overall dimensions | 85 |
| Unit hydraulic systems | 88 |
| Unit electric systems..... | 90 |
| Part V – Scheduled maintenance program - Servicing - Warranty conditions | 93 |
| Scheduled maintenance and servicing | 94 |
| Servicing | 95 |
| Warranty conditions | 96 |
| Forms for periodic checks (1 ÷ 10 Years)..... | 97 |
| Appendix I – Certifications | |



Puma Evo

***PART I* - INSTRUCTIONS USE AND MAINTENANCE HANDBOOK**

IMPORTANT NOTICE

This unit is a medical device for dental treatment conforming to EEC Directive 93/42 - MEDICAL DEVICES - (see enclosed certification of compliance) and with CEI EN 60601-1 standard (General standard for the safety of electromedical equipment).

It is intended to be used by dentists only, who may avail themselves of the assistance of authorized personnel.

We prescribe to read the instructions contained in the users' manual carefully before using the unit.

Furthermore, before using any of the devices connected to the dental unit, **we prescribe to** read the instructions attached to each single device carefully.

The instructions for installing the device and the instructions for technical service and repair are held by the "CASTELLINI AUTHORISED" TECHNICIAN IN POSSESSION OF A VALID LICENCE.

The Manufacturer will not be held responsible for the safety, reliability, or performance of the equipment in the event of civil or penal proceedings if:

- a) the essential environmental requirements as stated in the "Table on Compliance of Installations, Premises and Supply" are not met;
- b) assembly, additions, adjustments, re-settings, repairs are not performed by **"AUTHORISED CASTELLINI TECHNICIANS" IN POSSESSION OF A VALID CASTELLINI IDENTIFICATION CARD;**
- c) any medical devices other than those authorised by Castellini itself or devices that fail to meet the compatibility parameters specified by Castellini S.p.A. are connected to Castellini equipment;
- d) unauthorised modification, arbitrary tamperings, incorrect maintenance operations are carried out or if non-original spare parts and/or components are used;
- e) the equipment is not used in compliance with the instructions for use (as set out in the use and maintenance manual) or if it is used for purposes other than those for which it is designed;
- f) the power, water and compressed air supply, the water drainage system and the air extraction system (where applicable) do not comply with the conditions stated in the use and maintenance manual (see "preparing for installation" paragraph and equipment installations plan, scale 1:1 code F2210587 *(for ambidextrous version)* and code F2210B588 *(for right-hand version)*) and comply with the country legal provisions;
- g) scheduled technical maintenance is not performed at the times indicated;
- h) the user does not undertake all routine maintenance work and does not comply with the directions and rules in this use and maintenance manual.

Failure to comply with the above conditions automatically voids the guarantee terms, and can endanger the safety requirements defined under 93/42 EEC Norm, transferring full responsibility for safety and EEC mark compliance for the product on to those responsible for carrying out the operations described above.

DENTAL CARE SETTING: rules and recommendations

Besides complying with the requisites provided by local laws for health care facilities, the room should:

- be at least 2.50 m in length (optimal: 3.30 m) on its shorter side;
- have washable flooring capable of withstanding shocks and chemical agents, e.g. porcelain stoneware, with no gaps between the tiles and, if possible the surface where the walls and floor meet should be rounded to facilitate cleaning;
- have walls covered up to h. 2.00 m with washable materials resistant to chemical agents;
- have lighting provided by two ceiling fixtures with a double fluorescent tube, daytime light 5500°K, covered by alveolar grids, arranged longitudinally over the chair, so that the long sides are parallel;
- be free of non-sanitary curtains, upholstery, furniture and furnishing complements, ornamental plants.

Before installing the dental unit: the principal of the Surgery must verify that the plumbing for water supply and drainage, air supply lines, centralised suction lines (where applicable) and electrical system all meet requirements. He/she must provide for any necessary work to be done, following the instructions shown on the installation layout on a scale of 1:1 code F2210587 (*for ambidextrous model*), code F2210B588 (*for right-hand model*), which is supplied on request prior to installation, and the guidelines provided in the table "Conformity of Equipment, Environment and Supply Systems".

SETTING-UP PROCEDURES

Once the equipment is installed, the following operations must be performed before it may be used:

- Sterilization of instruments (see part "Operating Instruments").
- Sterilization or disinfection of all sterilizable parts supplied non-sterilized and disinfection of upholstery and any parts normally coming into contact with patients (see par. on cleaning, disinfection and sterilization).
- **Performance of a spray pipes disinfecting cycle with a contact time (TC) of 10 mins (see Autosteril and Time-Flushing paragraph).** (see section on Autosteril and Time-Flushing).
- Application of disposable protections where required.
- Check that the burrs and tips are securely fitted into the instruments (see part "Operating Instruments").

USING SAFELY: rules and recommendations

To ensure that the equipment is used safely, the user must abide by the set standards of hygiene and professional diligence.

The following points should also be kept in mind:

- **during use:** dust and fragments of material from the patient's mouth or the device being used may be thrust into the surrounding environment (organic and inorganic particles, metal dust, liquids, potentially infected fluids and biological materials):

Personnel must duly protect their eyes, breathing passages, mouth and skin

by wearing safety glasses, face shields, masks and disposable gloves.

Operate the suction system at high speed in all operations likely to result in a discharge of materials, dust and aerosols to minimise their dissemination.

- During use, materials and microorganisms coming from a patient may penetrate into the waterlines and be expelled into the next patient and into the environment. The passive systems of protection installed in this equipment (No-retraction system, Barrier Effect, etc.) minimise the risk but cannot eliminate it completely:

We recommend performing a spray pipes disinfecting cycle with a contact time (TC) of 10 min at the start of each working day and after use on each patient.

- the instruments have exposed tips and sharp parts (burrs and other rotating instrument attachments, scaler tips etc.): take care to **avoid accidental cuts and punctures;**
- **after use: Remove** the aforesaid parts from the instruments;

Do not leave sharp and/or pointed parts mounted on the equipment when it is left unattended;

It is mandatory to sterilize the cord-attached instruments or their removable invasive parts, after washing and disinfecting the surfaces (see specific instructions). Sterilization must take place in a steam autoclave at 135°C, 2.1 bars (sterilization requisites also prescribed by Italian Law, Health Minister's Decree of 28.09.1990, art. 4);

It is mandatory to regularly carry out the sanitization procedures described in this manual in the paragraph on "cleaning, disinfection, sterilization";

- it is not advisable to use drinking water to supply the dental unit since it may lead to the formation of a biofilm in the waterlines and thus facilitate germ proliferation inside the unit itself.

It is recommended to supply the unit exclusively with dedicated liquids (Isotonic Saline Solution or It.Ph. Purified Water) using the Separate Supply system.

The Principal of the Dental Surgery is responsible for ensuring that the equipment, environment and water supply comply with the basic requisites shown in the table below:

TABLE OF CONFORMITY OF EQUIPMENT, *Environment, Water Supply*

| ITEM | ESSENTIAL REQUIREMENTS |
|--|---|
| <input type="checkbox"/> Premises | a) protected from risk of explosion, non pressurized b) temperature between 10 °C and 40 °C c) Relative humidity between 30 % and 75 % d) Air pressure between 700 hPa and 1060 hPa (700 ÷ 1060 mbar) |
| <input type="checkbox"/> Electrical installation | a) compliance with regulations concerning electrical installations in premises used for medical purposes. All power and water supply installations must comply with the country legal provisions. b) Single-phase mains current, 230 V ± 10% - 50/60 Hz ± 10 % frequency |
| <input type="checkbox"/> Electrical power supply | Adequate for power requirements, as specified on the appliance's rating information plate Single-phase power 230 V - 50/60 Hz Maximum allowed variation on electrical power supply: ± 10 %. Max absorbed power 1,45 kVA The unit is fitted with a terminal board for connection to a permanent power supply system. Upstream from the unit have to be installed a differential, bipolar switch for at least 16 A - 250 V with differential operating time current $I\Delta N = 0,03$ A The electrical wiring of the room and the heart connection must comply with the current regulations. The addition of an air-compressor will require a power supply and safety fuse that must be independent from the unit. |
| <input type="checkbox"/> Water supply | Compliance with the country's legal provisions on drinking water |
| <input type="checkbox"/> Water treatment plant | Compliance with the country's legal provisions on drinking water |
| <input type="checkbox"/> Water supply | Drinking water for domestic use, duly filtered and decalcified, for mouth rinse cup and cuspidor a) hardness: 15÷-20 °F (French degrees) b) pressure: 300÷500 kPa (3 ÷5 bars) c) flow: ≥ 3 l/min at 450 kPa (4.5 bars) Should the pressure be lower than 300 kPa (3 bars), install a device upstream from the dental unit to ensure the necessary pressure (autoclave). Should the pressure exceed 500 kPa (5 bars), install a suitable pressure-reducing device upstream from the dental unit. The water supply line must be fitted with an isolating valve. N.B.: To avoid the risk of contaminating the water supply as a result of the possible backflow of liquid from the dental unit, after irrigating tips have come into contact with the patient or chemical agents, instruments may be supplied using ONLY one of the following systems: 1 - Solely with liquid contained in the separate tank installed in the dental unit; the separate supply system option must always be selected (see section on "Separate supply system" in the user instructions). 2 - With mains water, after a dental water supply system conforming to standard CEI EN 1717 has been installed upstream from the dental unit to guarantee the physical separation of mains water and instrument sprays (e.g. "WEK" Metasys or equivalent). Before the mounting of the unit: WE PRESCRIBE TO clean thoroughly all pipes to prevent impurities from fouling the unit's water/air circuits, and to bleed extensively the water supply pipe so that no air bubbles remain in the system. |
| <input type="checkbox"/> Compressed air plant | The compressor must be installed in a well ventilated room and not in close proximity of heat sources or exhaust air from the vacuum system. |
| <input type="checkbox"/> Compressed air supply | a) Compressed air pressure between 550 kPa and 700 kPa (5,5 ÷ 7 bar) b) Capacity in excess of or equal to 50 l/min at 400 kPa (4 bar) c) Dew point: less or equal to 10 °C The compressor air supply line must be fitted with an isolating valve. |
| <input type="checkbox"/> Vacuum system | The pipework system must be installed if you intend connecting the unit to a centralized suction system. For a single dental unit it is sufficient to connect the aspirator to the unit through the appropriate tube supplied. The vacuum suction system must discharge the exhaust air outside to atmosphere. Air flow rate 300 l/min. Vacuum value 10 kPa (0,1 bar) |
| <input type="checkbox"/> Waste water line | We recommend a waste line slope of 1 cm for each metre of distance from the unit to the main waste. A "p" trap must be installed on the drain line outside the unit. |

MAINTENANCE AND REVISIONS

The dental patient chair, dental unit (including all the tools and devices connected to it, with the exception of high speed drills), operating lamp, x-ray equipment, compressor and any other device manufactured by Castellini S.p.A. that forms an independent unit must undergo the scheduled annual maintenance operations (except where otherwise indicated in the part on "Scheduled Maintenance Operations" in this Manual) by technicians carrying a valid Castellini identification card, 365 days after installation, regardless of whether they have actually been used or not.

High speed drills manufactured by Castellini S.p.A. must undergo the scheduled annual maintenance operations performed by qualified technicians authorised by Castellini (except where otherwise stated in the part on "Scheduled Maintenance Operations" in this Manual).

The owner of the equipment is responsible for booking the services of the Castellini technician at all times.

The high speed drill must be returned to Castellini S.p.A. three years after installation to be reconditioned at the manufacturing plant.

Subsequently, high speed drills should be reconditioned every three years, in addition to undergoing the above described scheduled annual maintenance operations.

CIRCUIT DIAGRAM, LISTS OF COMPONENTS, CALIBRATION INSTRUCTIONS

Castellini S.p.A. undertakes to provide on request circuit diagrams, lists of components, calibration instructions or any other information that may be required by qualified technicians authorized by Castellini and in possession of a valid professional licence to repair those parts of the equipment that may be repaired.

Castellini S.p.A. reserves the right to modify the products at any moment without notice.

ATTENTION

**- This unit complies with the EMC 89/336 EEC Directive, according with the CEI EN 60601-1-2 Standard.
During the working, this unit will not cause radio interference to the electric network (*)**

(*) See chapter: "INFORMATIONS ABOUT CONFORMITY BY "Puma Evo" DENTAL EQUIPMENT AT EEC CEI EN 60601-1-2 NORMS - 2001 EDITION".

SCRAPPING

If scrapped, the equipment must be disposed of in accordance with the provisions of applicable legislation.

The materials used to construct the equipment do not constitute a hazard for humans or animals in the event of contact or exposure.

For disposal of the amalgam separator (if present), strictly follow the instructions and warnings given in the section "ACCESS TO AMALGAM SEPARATOR".

INFORMATIONS ABOUT CONFORMITY BY "Puma Evo" DENTAL EQUIPMENT AT CEI EN 60601-1-2 NORMS - 2001 EDITION

Annex A

| The "Puma Evo" unit is suitable for use in the specified electromagnetic environment. The purchaser or user of the "Puma Evo" unit should assure that it is used in an electromagnetic environment as described below: | | |
|--|------------|--|
| Emission test | Compliance | Electromagnetic Environment |
| Radiated and conducted RF emission | Class B | The "Puma Evo" unit is suitable for use in domestic establishments directly connected to the low voltage power supply network which supplies buildings used for domestic purposes |
| CISPR 11 | Group 1 | The "Puma Evo" unit uses RF energy only for its internal function. Therefore, the RF emission is very low and not likely to cause any interference in nearby electronic equipment. |
| Harmonic emissions | Complies | The "Puma Evo" unit is suitable for use in establishments directly connected to a public low voltage power supply network. |
| Voltage fluctuations/ flicker emissions CEI EN 61000-3-3 | Complies | The "Puma Evo" unit is suitable for use in establishments directly connected to a public low voltage power supply network. |

Annex B

| The "Puma Evo" unit is suitable for use in the specified electromagnetic environment. The purchaser or user of the "Puma Evo" unit should assure that it is used in an electromagnetic environment as described below: | | | |
|--|---|--|-----------------------------|
| Immunity Test | CEI EN 60601-1-2 Test level | Compliance level | Electromagnetic Environment |
| Electrostatic discharge (ESD) CEI EN 61000-4-2 | 6 kV contact 8kV air | CEI EN 60601-2 Test level | Residential/Hospital |
| Radiated RF CEI EN 61000-4-3 | <u>Non-life-supporting Equipment</u> 3 V/m 80 MHz to 2,5 GHz | CEI EN 60601-1-2 Test level | Residential/Hospital |
| Conducted Rf CEI EN 61000-4-6 | <u>Life-supporting equipment</u> 10 V/m 80 MHz to 2,5 GHz <u>Non-life-supporting equipment</u> 3 V 150 kHz to 80 Mhz <u>Life-supporting equipment</u> 3 V (outside ISM band) 10 V (inside ISM band) | CEI EN 60601-1-2 Test level CEI EN 60601-1-2 Test level | |
| Electrical fast transient/burst CEI EN 61000-4-4 | 2 kV for power supply lines 1 kV for input/output lines > 3 m | CEI EN 60601-1-2 Test level | Residential/Hospital |
| Surge CEI EN 61000-4-5 | 1 kV differential mode 2 kV common mode | CEI EN 60601-1-2 Test level | Residential/Hospital |

(see next →)

| | | | |
|--|--|--------------------------------|----------------------|
| Voltage dips, short in interruptions and voltage variations on power supply input lines CEI EN 61000-4-11 | 0% U _n for 0,5 cycles 40% U _n for 5 cycles 70% U _n for 25 cycles 0% U _n for 5 s | CEI EN 60601-1-2 Test level | Residential/Hospital |
| Power frequency (50/60 Hz) magnetic field CEI EN 61000-4-8 | 3 A/m | CEI EN 60601-1-2 Test level | Residential/Hospital |

Annex C

Recommended Separation Distance for non-LIFE SUPPORTING EQUIPMENT

| RF Source | Typical Rated Power (W) | Distance (m) |
|---|-------------------------|--------------|
| microcellular phone CT1, CT2, CT3 | 0,01 | 0,4 |
| DECT cellular phone, wireless information technology equipment (modems, LANs) | 0,25 | 2 |
| cellular phone, hand-held (USA) | 0,6 | 3 |
| cellular phone, hand-held (e.g. GSM and NMT, EUROPE; DECS 1800) | 2 8 | 6 11 |
| walkie-talkie (rescue, police, fire, maintenance) | 5 | 9 |
| cellular phone, bag | 16 | 16 |
| mobile radio (rescue, police, fire) | 100 | 40 |
| <p>For transmitter using frequencies below 800 MHz, the DISTANCE can be estimated using Equation A:</p> $d = 4\sqrt{P}$ <p>For transmitters using frequencies between 800 MHz and 2 GHz, the DISTANCE can be estimated using Equation B:</p> $d = 2.3\sqrt{P}$ <p>where P is the rated power of the trasmitter in watt (W) according to the transmitter manufacturer.</p> | | |

TECHNICAL DATA EQUIPMENT

UNIT

**MEDICAL DEVICE CLASS IIa By 93/42 EEC DIRECTIVE
ELECTRO MEDICAL EQUIPMENT CLASS I - TYPE B By CEI EN 60601-1 Standard
THE EQUIPMENT CANNOT BE USED WHEN FLAMMABLE ANESTHETIC MIXTURES CONTAINING AIR OR OXIGEN OR NITROUS OXIDE ARE PRESENT**

DEGREE OF PROTECTION AGAINST WATER INFILTRATION: **IPX0**

POWER SUPPLY
 MAXIMUM POWER INPUT (Unit+chair+suction system working together) 1450 VA
 MAINS VOLTAGE 230 V~
 SINGLE-PHASE A.C AT 50 Hz
 INTERMITTENT OPERATION (Refer to the use specifications)

WATER SUPPLY (See note in "TABLE OF EQUIPMENT CONFORMITY") DRINKING WATER
 PRESSURE 300 ÷ 500 kPa (3 ÷ 5 bar)
 MAXIMUM CONSUMPTION 3 l/min at 450 kPa (4.5 bar)
Should the pressure be lower than 300 kPa (3 bars), install a device upstream from the dental unit to ensure the necessary pressure (autoclave).
Should the pressure exceed 500 kPa (5 bars), install a suitable pressure-reducing device upstream from the dental unit.

The water inlet MUST BE fitted with a cut-off valve.

AIR SUPPLY
 PRESSURE 550 ÷ 700 kPa (5,5 ÷ 7 bar)
 CONSUMPTION 50 l/min at 400 kPa (4 bar)

VACUUM
 AIR FLOW RATE ≥300 l/min
 VACUUM VALUE ≤ 10 kPa (0.1 bar)

UNIT WEIGHT 90 kg
UNIT + MOTOR CHAIR WEIGHT 225 kg
UNIT + OPERATING LIGHT + MOTOR CHAIR WEIGHT 238 kg

ADDITIONAL WEIGHT ON THE INSTRUMENT TRAY OF THE DENTAL UNIT (with self-balancing of the arm): **1 kg**
MAXIMUM ADDITIONAL WEIGHT ON THE INSTRUMENT TRAY OF THE DENTAL UNIT (w/o self-balancing of the arm): **2 kg**

"DAMA" MOTOR CHAIR

**MEDICAL DEVICE CLASS I - By 93/42 EEC DIRECTIVE
ELECTRO MEDICAL EQUIPMENT CLASS I TYPE B - By CEI EN 60601-1 Standard
THE EQUIPMENT CANNOT BE USED WHEN FLAMMABLE ANESTHETIC MIXTURES CONTAINING AIR OR OXIGEN OR NITROUS OXIDE ARE PRESENT**

POWER SUPPLY VOLTAGE 230 V~
 SINGLE-PHASE A.C. at 50/60 Hz
 POWER OF OPERATION COMMAND 24 V
 INTERMITTENT OPERATION 1 min of work
 14 min of rest
 135 kg



WHOLE WEIGHT
 HEIGHT FROM THE POINT OF SEAT

"DAMA" for "Puma Evo"
right-hand version
 min 36 cm
 max 79 cm

"DAMA" for "Puma Evo"
ambidextrous version
 min 41 cm
 max 84 cm

BACKREST HEIGHT FROM THE FLOOR

"DAMA" for "Puma Evo"
right-hand version
 min 37 cm
 max 80 cm

"DAMA" for "Puma Evo"
ambidextrous version
 min 42 cm
 max 85 cm

MAX. INCLINATIONS

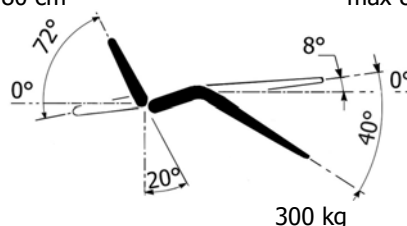

MAX LIFTING CAPABILITY

UNIT



Mark of Conformity to 93/42 ECC Directive "MEDICAL DEVICE", equipped by correspondent number to the NOTIFIED ORGANIZATION (BSI - Notified Body number), authorized to issue the Conformity Certificate



IDENTIFICATION LABEL

2005 **year of production (UNI EN 980)**



SYMBOL CORRESPONDING TO PART APPLIED TYPE B as per CEI EN 60601-1:
It indicates the degree of protection against direct and indirect contacts.

SN

SERIAL NUMBER OF THE UNIT (UNI EN 980)

Through this number may be recognized the year and the month of production. The first two pictures indicate the year other one letter indicated the month of production (for example 05A = January 05).

TYPE

COMMERCIAL DENOMINATION OF THE UNIT

V

CONNECTION VOLTAGE TO THE MAINS

~

ALTERNATE CURRENT

Hz

MAINS FREQUENCY IN HERTZ

kVA

MAXIMUM POWER IN KILOVOLTAMPERE ABSORBED FROM THE UNIT



Symbol to draw attention about further information written on "USE AND MAINTENANCE HANDBOOK"

CONTINUOUS OPERATION DUTY-TYPE OF PARTS SPECIFIED

(according to the following user instructions):

- TURBINE AND SCALER 20 min work
 10 min rest
- MICROMOTORS 5 min work
 25 min rest
- SYRINGE 10 s work
 5 min rest
- POLYMERIZING LIGHTS 60 s work
 13 min rest
- ASPIRATOR
(with working tips) 10 min work
 20 min rest
- "DAMA" chair 1 min work
 14 min rest



Symbol released from RAEE Directive (Dir. 2002/96/ECC) signed applicable legislation of the Country.

It indicate that, when the equipment will be scrapped, it will be destroyed in differential way, according to the overwrite Directive.

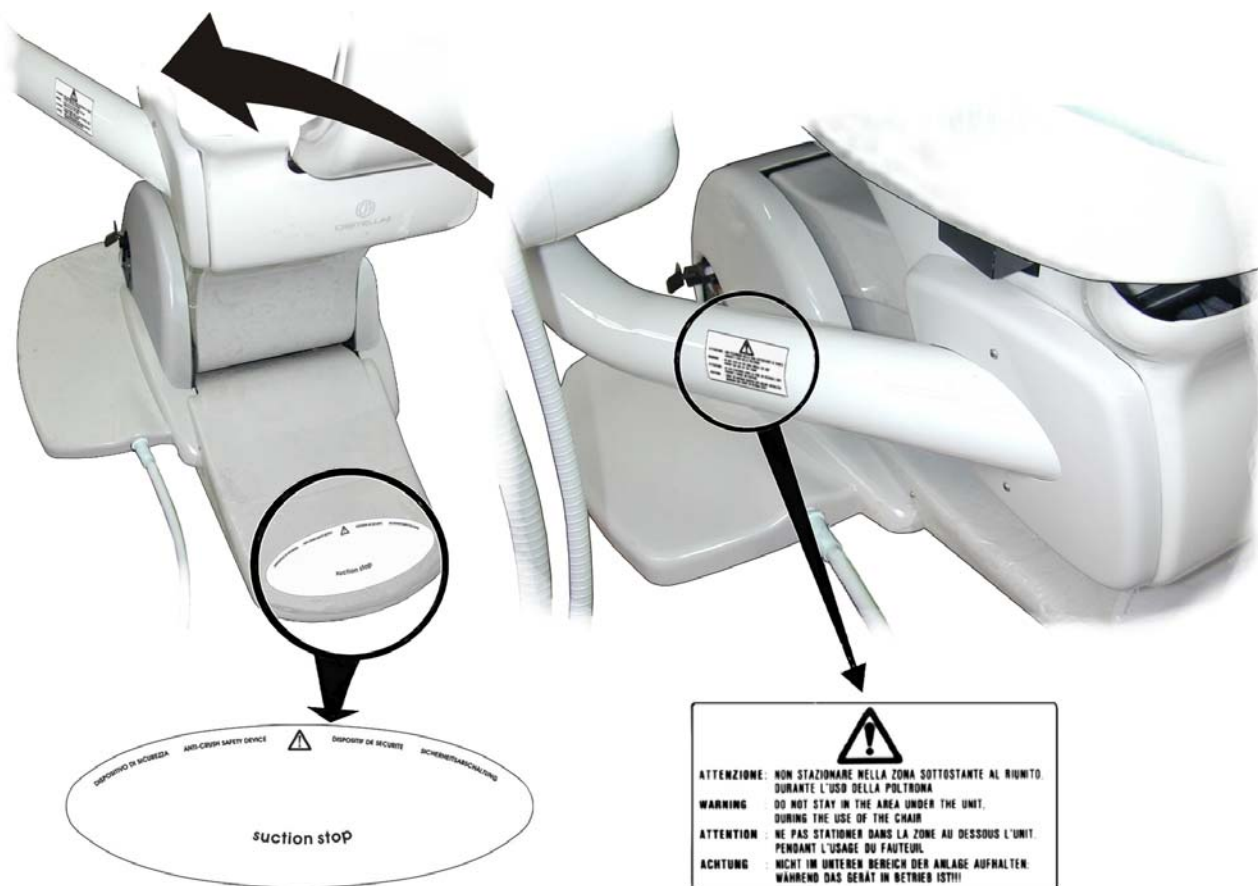

Chair anti-crush safety system/ Suction Stop device

Warnings for chair lowering

- ATTENZIONE:** **DISPOSITIVO DI SICUREZZA ANTI-SCHIACCIAMENTO**
- WARNING:** **ANTI-CRUSH SAFETY DEVICE**
- ATTENTION:** **DISPOSITIF DE SECURITE ANTI-ECRASEMENT**
- ACHTUNG:** **SICHERHEITSABSCHALTUNG**
- ATENCION:** **DISPOSITIVO DE SEGURIDAD ANTIATRAPE**
- ATTENTIE:** **VERPLETTERINGSBEVEILIGING**

If the chair meets with an obstacle while being lowered, the pressure on the base plate will trigger the automatic safety system: the downward movement will stop immediately and the chair will rise a few centimetres to free the obstacle.

Another automatic stop system controls the backrest lowering function.

When the chair is stationary, pressing on the base plate will activate the dental unit suction stop device.

The assistant's tray is also fitted with an anti-crush safety feature.

If the chair backrest interferes with the handle of the aforesaid tray as it returns to an upright position, the chair must stop immediately and lower itself a few centimetres.

- ATTENZIONE:** **NON STAZIONARE NELLA ZONA SOTTOSTANTE IL RIUNITO, durante l'uso della poltrona**
- WARNING:** **DO NOT STAY IN THE AREA UNDER THE UNIT, during the use of the chair.**
- ATTENTION:** **NE PAS STATIONER DANS LA ZONE AU DESSOUS L'UNIT, pendant l'usage du fauteuil**
- ACHTUNG:** **KEINE GEGENSTÄNDE UNTER DIE ANLAGE STELLEN während der Behandlungsstuhl arbeitet.**
- ATENCION:** **NO COLOCAR NINGUN OBJETO DEBAJO DEL EQUIPO durante el funcionamiento del sillón**
- ATTENTIE:** **BEGEEF U NIET ONDER DE BEHANDELUNIT, als de stoel in gebruik is.**

MEDICAL DEVICES APPLIES TO THE UNIT

The dental units "Puma Evo" may be completed with the following devices:

- "DAMA" dental CHAIR:
- "LUNA" operating light.
- SURGICAL SUCTION single-surgery UNIJET model or, alternatively, setup for centralized suction systems:
 - Centralised liquid ring suction system;
 - Centralised air type "C" suction system;
 - Centralised suction system with "DÜRR COMBI CAS 1" type amalgam separator device;
- Suction cannulas: bearing EC mark of conformity with Dir. 93/42 EEC, sterilizable or disposable
 - rigid mist cannula with 15.7 - 16.2 mm-diameter connector
 - rigid blood/saliva ejector cannula with 10.7 - 11 mm-diameter connector
 - flexible blood/saliva ejector cannula with 6.0 - 6.5 mm-diameter connection
- "ASSISTANT'S TRAY" unit from 4-WAY, including one of the following supplementary instruments, plus 2 suction tubes:
 - 2 suction canulas.
 - 1 syringe model THREESTERIL (*alternative options*)
 - 1 curing lamp "LEDA" model (*alternative options*).
- DENTIST TABLE with the following instruments (max. 4): "Puma Evo":
- DENTIST TABLE with the following instruments (max. 5): "Puma Evo 5"
- ABLATOR handpiece model:

| | | |
|--|----------------|------------------|
| | PIEZOSTERIL 5, | |
| | PIEZOLIGHT 5 | (alternatively); |
- SYRINGE model:

| | | |
|--|---------------------------|---------------------------|
| | MULTISTERIL 2 TITANIUM F, | |
| | MULTISTERIL 2 | (<i>alternatively</i>), |
| | MULTISTERIL 2L | (<i>alternatively</i>); |
| | THREESTERIL | (<i>alternatively</i>) |
- ELECTRIC MICROMOTOR model:

| | | |
|--|---------------|---------------------------|
| | IMPLANTOR 2L, | |
| | IMPLANTOR 2 | (<i>alternatively</i>); |
- *- CAMERA FOR DENTAL INSPECTIONS model:

| | | |
|--|-----------|-----------------------------|
| | VIDEORCAM | (<i>only by request</i>); |
|--|-----------|-----------------------------|
- TURBINE model:

| | | |
|--|---------------------------|------------------|
| | CLEANAIR 2000, | |
| | CLEANLIGHT 2000 | (alternatively), |
| | HI-POWER 2 CERAMIC | (alternatively), |
| | TITANIUM GOLD 2 | (alternatively), |
| | TITANIUM GOLD 2 MINIATURE | (alternatively); |

* See "VIDEOR" handbook.

CASTELLINI firm doesn't authorize the application of other devices unnamed in this list.

UNIT OPERATIONS

MAIN SWITCH

The unit is provided with a combined main switch, positioned in the lower part of the chair (Pict. 4 - part. **4.1**), which activates or disactivates au together (position **I** or position **0** of the lever) the electric supply, the water supply and the compressed air supply, which are all necessary to operate the unit.

WE RECOMMEND turning off the aforesaid main switch each day, before switching off for the night and before breaks lasting a few hours or more.

WE RECOMMEND turning off the main switch before each technical repair or maintenance that requires the access to the inner parts of the units protected by covers.

The Castellini S.p.A. Company is not responsible for any damages to person or things, caused by the failure to perform the operation above described.

CONTROLS

The controls panel on the doctor's table has direct controls described in pictures 2B.

The controls panel on the assistant's table has direct controls described in pictures 3B.

The foot controls are described on the pages: "FOOT CONTROLS FUNCTIONS", other controls are indicated at the Cpt. "FOOT CONTROL FUNCTIONS"

OPERATIVE INSTRUMENTS

The operative instruments must be activated through the foot control (see "FOOT PEDAL FUNCTIONS").

WARNING:

- The movements of the instruments table, of the assistant table, and of the light must be done using the handles on the tables and on the light.

PICTURES AND DESCRIPTIONS

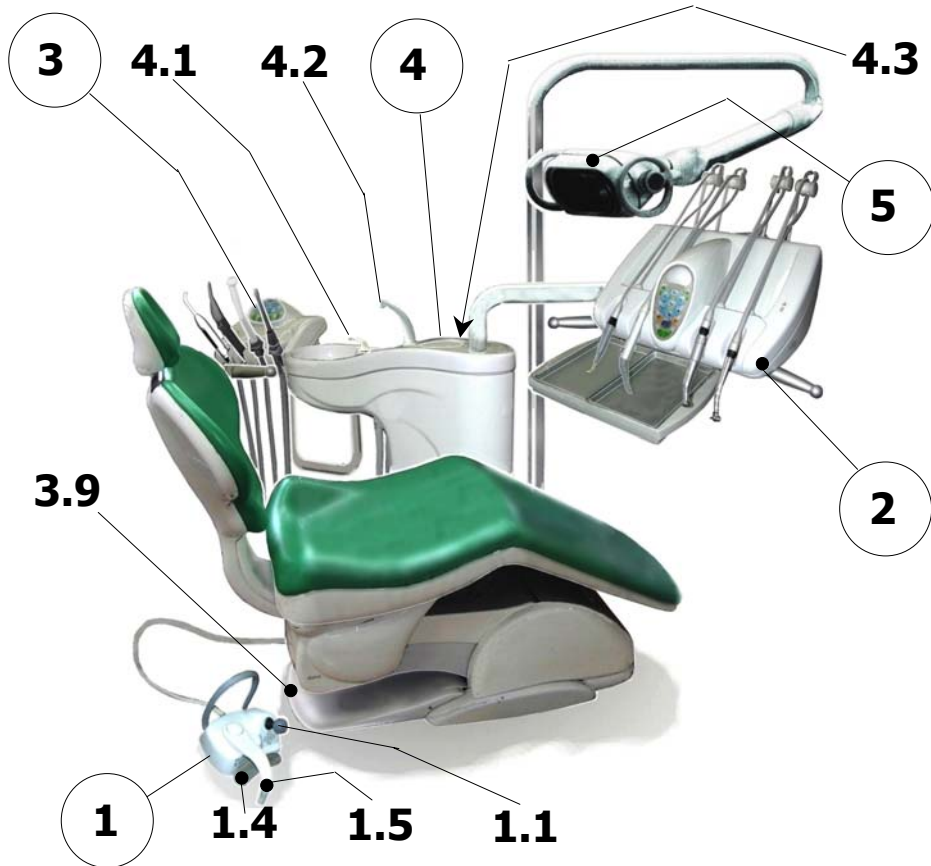

Pict. 1 - "Puma Evo" unit (S.P.R.I. table version) + "DAMA" chair

"Puma Evo" and "Puma Evo" Unit (S.P.R.I. and HANGING CORDS Dentist's table version) (Picts. 1 and 1A)

- 1** - ELECTRIC FOOT CONTROL.
- 1.1** - Chair movement/ instrument function selection control. (*by request*).
- 1.4** - Air spray and chip air to instruments on /memorised chair position recall control.
- 1.5** - Instruments/operating lamp on control.
- 2** - DENTIST'S TABLE.
- 3** - ASSISTANT'S TABLE.
- 3.9** - Base plate controlling the anti-crush safety system and "SUCTION STOP" system.
- 4** - WATER UNIT.
- 4.1** - Spout for water to cuspidor.
- 4.2** - Jet for water to the bowl.
- 4.3** - Holder-instruments bowl for AUTOSTERIL System.
- 5** - "LUNA" OPERATING LAMP (*only if required*).

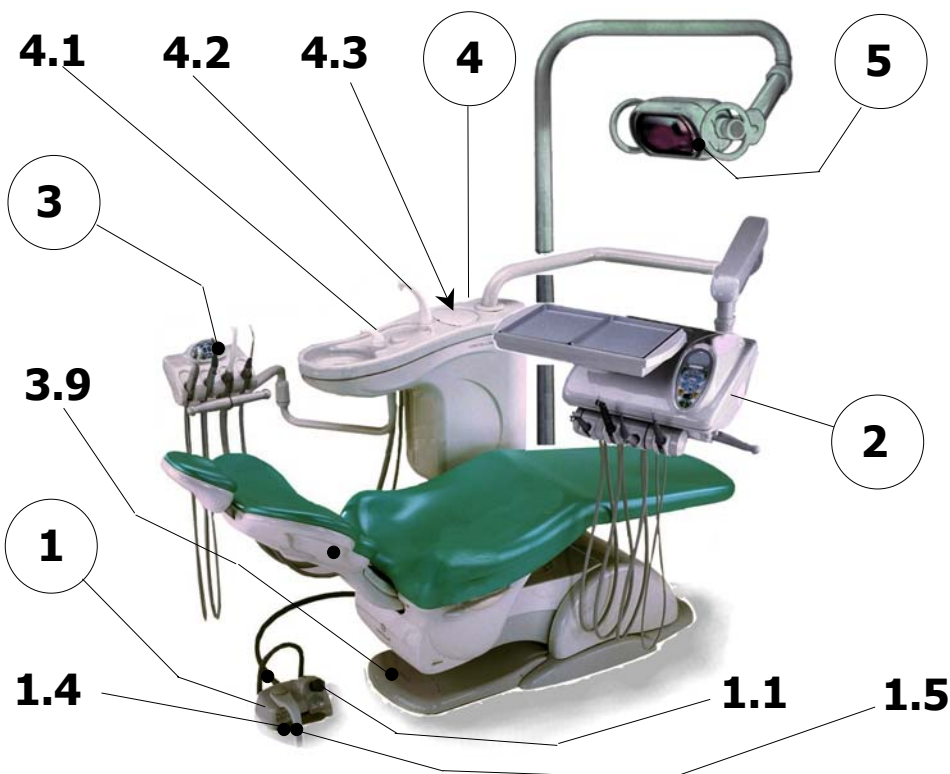

Pict. 1A - "Puma Evo CP" unit (HANGING TUBES table version) + "DAMA" chair

Dentist's table and control panel (Picts. 2A, 2B and 2C)



Pict. 2A – Dentist's table S.P.R.I. version

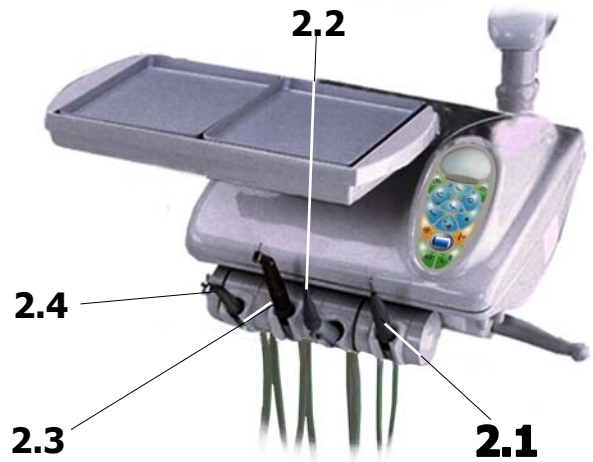

Pict. 2B – Dentist's table HANGING CORDS version

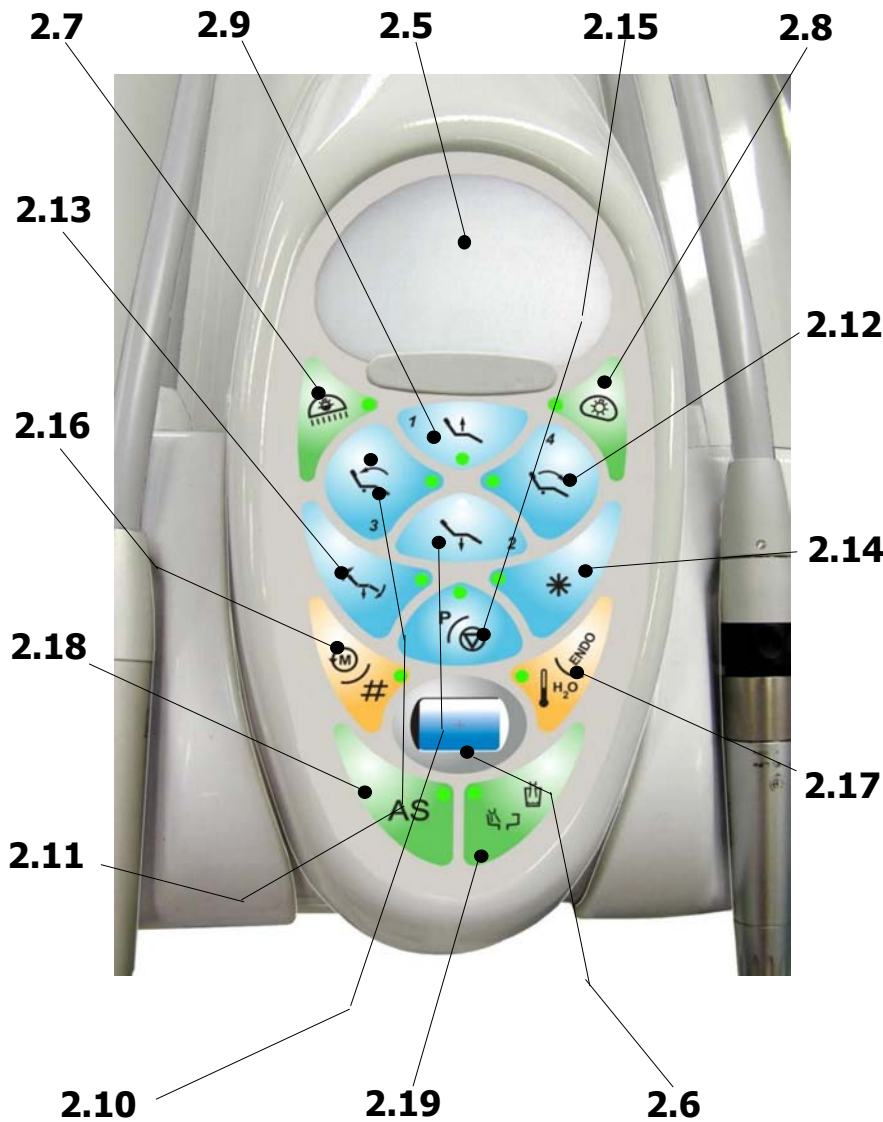

Pict. 2C – Control panel

- 2.1** - Scaler handpiece.
- 2.2** - Syringe.
- 2.3** - Micromotor.
- 2.4** - Turbine.
- 2.5** - X-Ray viewer.
- 2.6** - Motor rpm and scaler power display.
- 2.7** - ON/OFF scalytic lamp pulse control (*).
- (* **N.W.:** Pushing control for 1 sec. to lighting the pilot light intermittently; then push it again to obtain 3 regulation steps: HIGH – NORMAL – LOW.
- 2.8** - ON-OFF X-ray viewer light.
- 2.9** - Chair up control / Position **1** recall control.
- 2.10** - Chair down control / Position **2** recall control.
- 2.11** - Backrest down control / Position **3** recall control.
- 2.12** - Backrest up control / Position **4** recall control.
- 2.13** - Automatic reset direct control.
- 2.14** - Rinse position recall direct control.
- 2.15** - Stop all chair movements/recall memorised chair positions.
- 2.16** - Electric micromotor reverse-speed control and assistant call button when operating instruments are in rest position.
- 2.17** - Control for turning on the heater to supply water to the cup and syringe and ENDO control for ablator and micromotor.
- 2.18** - Control for Time-Flushing/Autosteril system.
- 2.19** - Control for water to glass/ bowl.

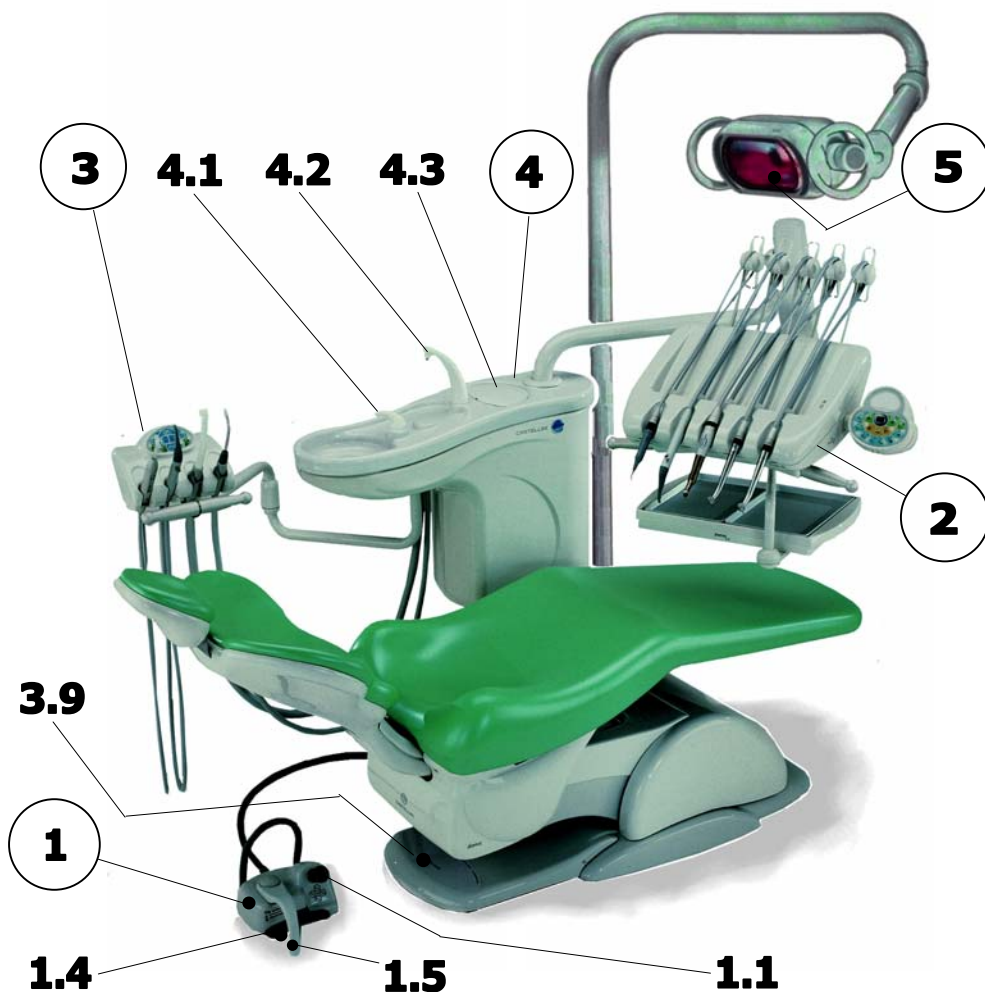

"Puma Evo 5" Unit (5 holder-instruments table version) (Picts. 1B and 2D)

- 1** - ELECTRIC FOOT CONTROL.
- 1.1** - Chair movement/ instrument function selection control. (by request).
- 1.4** - Air spray and chip air to instruments on /memorised chair position recall control.
- 1.5** - Instruments/operating lamp on control.
- 2** - DENTIST'S TABLE.
- 3** - ASSISTANT'S TABLE.
- 3.9** - Base plate controlling the anti-crush safety system and "SUCTION STOP" system.
- 4** - WATER UNIT.
- 4.1** - Spout for water to cuspidor.
- 4.2** - Jet for water to the bowl.
- 4.3** - Holder-instruments bowl for AUTOSTERIL System.
- 5** - "LUNA" OPERATING LAMP (only if required).

Pict. 1B – "Puma Evo 5" unit (5 holder instruments table version) + "DAMA" chair

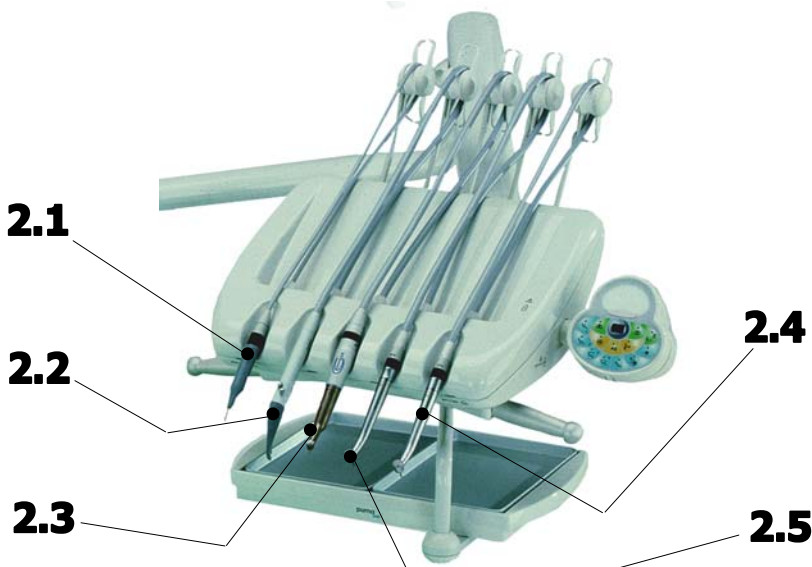

- 2.1** - Scaler handpiece.
- 2.2** - Syringe.
- 2.3** - Micromotor.
- 2.4** - Turbine.
- 2.5** - Additional turbine (only if required).

Pict. 2D – 5 holder-instruments table version

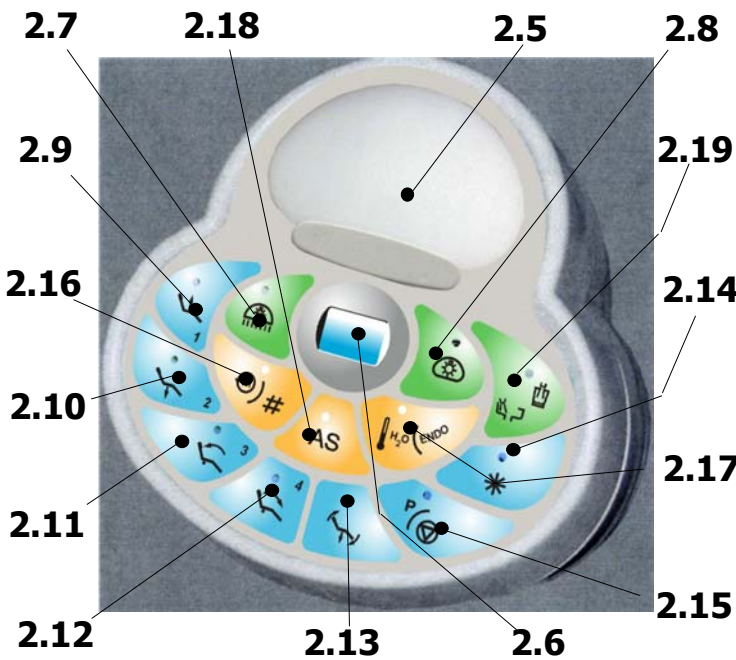

5 instruments-holder table control panel (Pict. 2E)

- 2.5 - X-Ray viewer.
- 2.6 - Motor rpm and scaler power display.
- 2.7 - ON/OFF scalytic lamp pulse control (*).
(* **N.W.:** Pushing control for 1 sec. to lighting the pilot light intermittently; then push it again to obtain 3 regulation steps: HIGH – NORMAL – LOW.
- 2.8 - ON-OFF X-ray viewer light.
- 2.9 - Chair up control / Position 1 recall control.
- 2.10 - Chair down control / Position 2 recall control.
- 2.11 - Backrest down control / Position 3 recall control.
- 2.12 - Backrest up control / Position 4 recall control.
- 2.13 - Automatic reset direct control.
- 2.14 - Rinse position recall direct control.
- 2.15 - Stop all chair movements/recall memorised chair positions.
- 2.16 - Electric micromotor reverse-speed control and assistant call button when operating instruments are in rest position.
- 2.17 - Control for turning on the heater to supply water to the cup and syringe and ENDO control for ablator and micromotor.
- 2.18 - Control for Time-Flushing/Autosteril system.
- 2.19 - Control for water to glass/ bowl.

Pict. 2E – "PUMA EVO 5" instruments-holder table control panel

2.21 - (rpm x 1000) Electric micromotor speed control.

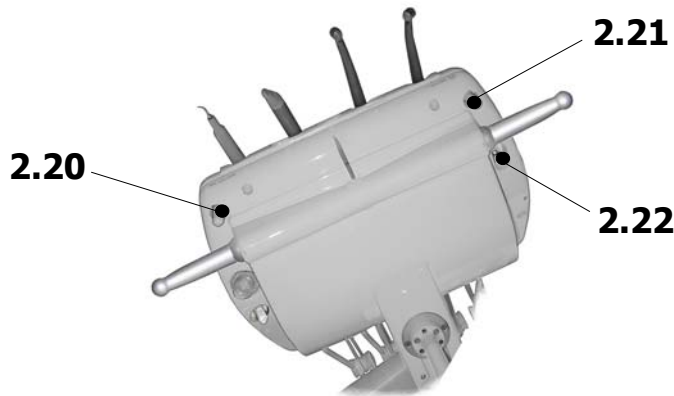

Assistant's table and controls panel (Picts. 2C, 3A and 3B)

- 2.20 - Scaler power control (**POWER**).
- 2.22 - Lever for selecting liquid supply to instruments.



Pict. 3A – 4 instruments assistant's table

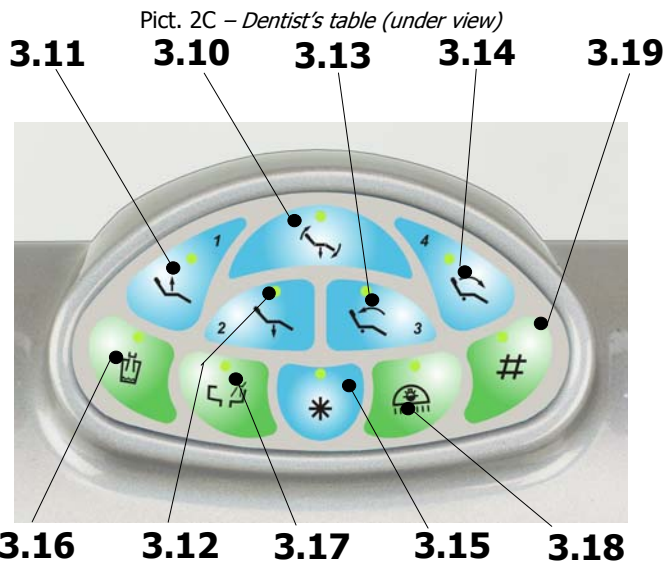

Pict. 2C – Dentist's table (under view)

- 3.1 - Additional syringe (*only if required*).
- 3.2 - Large aspiration typ.
- 3.3 - Small aspiration typ.
- 3.4 - Polymerizing light handpiece (*only if required*).
- 3.10 - Automatic reset direct control.
- 3.11 - Chair up control.
- 3.12 - Chair down control.
- 3.13 - Backrest down control.
- 3.14 - Backrest up control.
- 3.15 - Rinse position recall direct control.
- 3.16 - Control for water to glass.
- 3.17 - Control for water to bowl.
- 3.18 - ON/OFF scalytic lamp pulse control (*).
(* **N.W.:** Pushing control for 1 sec. to lighting the pilot light intermittently; then push it again to obtain 3 regulation steps: HIGH – NORMAL – LOW
- 3.19 - Assistant call button (*it goes on only when operating instruments are in rest position*).

Pict. 3B – Assistant's table controls panel

"Puma Evo Cart" Unit (Picts. 1C and 2E)



- 1** - ELECTRIC FOOT CONTROL.
- 1.1** - Chair movement/ instrument function selection control. (by request).
- 1.4** - Air spray and chip air to instruments on/ memorised chair position recall control.
- 1.5** - Instruments/operating lamp on control.
- 2** - SUPPORTING INSTRUMENT'S TABLE.
- 2.1** - Scaler handpiece.
- 2.2** - Syringe.
- 2.3** - Micromotor.
- 2.4** - Turbine.
- 3** - ASSISTANT'S TABLE.
- 3.9** - Base plate controlling the anti-crush safety system and "SUCTION STOP" system.
- 4** - WATER UNIT.
- 4.1** - Spout for water to cuspidor.
- 4.2** - Jet for water to the bowl.
- 4.3** - Holder-instruments bowl for AUTOSTERIL System.
- 5** - "LUNA" OPERATING LAMP (only if required).

Pict. 1C - "Puma Evo Cart" Unit + "DAMA" Chair

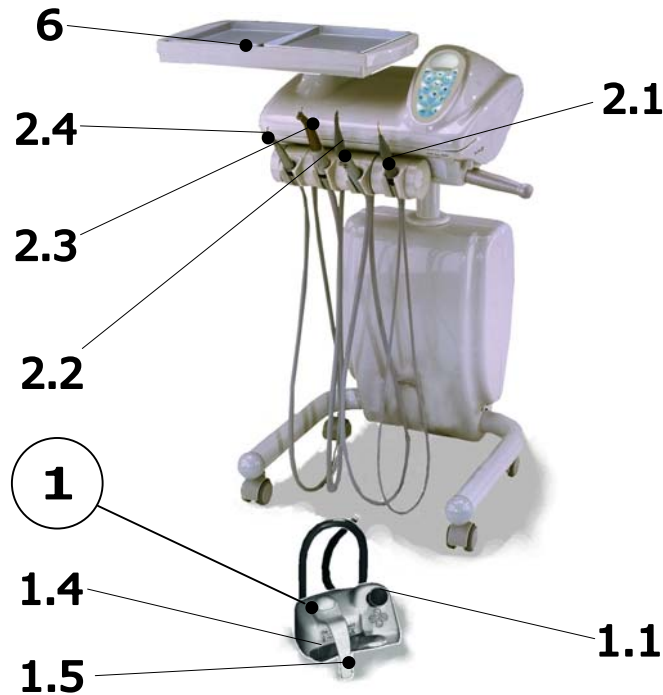

Pict. 2E - "Puma Evo Cart" Unit

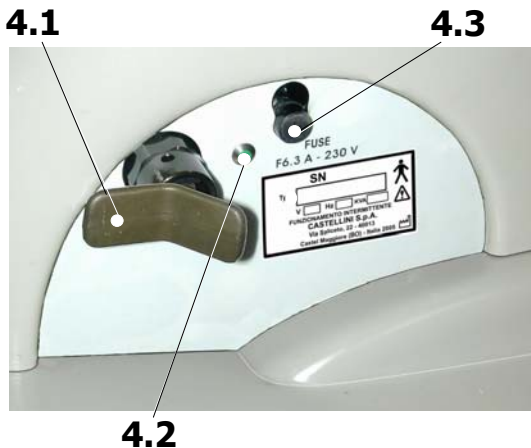

Connection box (Pict. 4)

- 4.1 - Main switch.
- 4.2 - ON lamp.
- 4.3 - F 6.3 A - 230 V power supply line fuse.

Pict.4 – Connection box

FOOT CONTROL FUNCTIONS (Pict. 5)

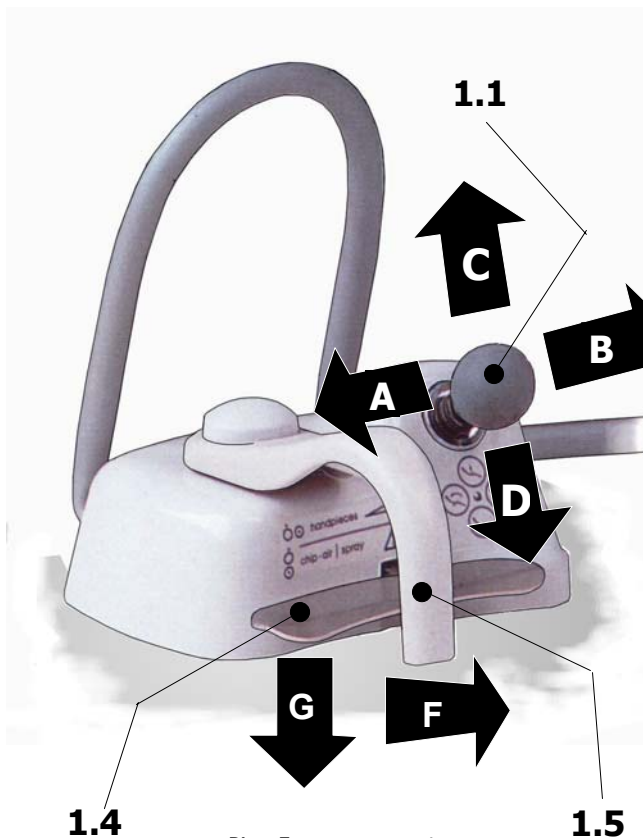

Pict. 5 – Foot control

CHAIR CONTROLS

Move the lever control (1.1) in the direction marked with **C** in the figure to lift the chair seat and in the opposite direction to lower it.

Turn the control knob (1.1) in the direction marked with **A** to lower the back and in the opposite direction, marked with **B**, to return to its upright position.

Pressing the lever (1.4) in the direction indicated by **G**, with the instruments at rest, and subsequently moving the control (1.1) in one of the 4 directions shown, will call up one of the 4 memorised work programs

The reset position can be recalled by pressing the lever (1.4) in the direction marked **G**, with instruments on stand-by, and subsequently turning the lever (1.5) in direction **F** to the end of its stroke.

INSTRUMENTATION CONTROLS

By extracting an instrument from the handpiece holder on the tray and rotating the lever (1.5) in the direction marked **F**, one obtains the following functions:

- Activation and adjustment of the turbine or air-powered or electric micromotor speed;
- Activation of the scaler handpiece.

By pressing the lever (1.4) in the direction marked **G** and simultaneously turning the lever (1.5) one enables the handpiece spray function (only when the instrument has been extracted).

CASTELLINI recommends using the spray when using micromotors with turning speeds higher than 20,000 rpm.

- By pressing the lever (1.4) in the direction marked **G**, without moving the lever (1.5) one obtains either the CHIP-AIR effect (a blast of air is issued from the turbine or micromotor to clean the operating field), (only when the instrument has been extracted).
- By moving the control (1.1) in direction **A** one enables/disables the electric micromotor turning direction inverter (only when the instrument has been extracted).

OPERATING LAMP CONTROL: with the chair and instruments on stand-by, by turning the lever (1.5) in direction **F** to the end of its stroke and holding it in position for approx. 1 second one enables/disables the work light.

Attention!: In the event of visible damage to the outer case of the foot control and/or control elements, do not use the equipment and contact the authorised service centre.

CHAIR MOVEMENTS

DIRECT CONTROL MOVEMENTS

RAISE - LOWER CHAIR / RECLINE-- UPRIGHT BACKREST



The movement controls (2.9, 2.10, 2.11 and 2.12 - pict. 2B) control the chair raising and lowering and backrest reclining and return functions. The chair will continue moving as long as the pushbutton is pressed (pushbutton LED on) and will stop immediately on its release (LED off).

MEMORISING CHAIR WORK POSITIONS

The chair can memorise positions set by the User: rinse, reset and 4 work positions.

- Use the movement controls (2.9, 2.10, 2.11 and 2.12) to take the chair to the desired position;



- Press the control (2.15) and keep it pressed for at least 1 sec. (the control LED will flash)

- Press the control you wish to associate to the chair position 2.9, 2.10, 2.11 2.12, 2.13, 2.14.

- Once memorisation has taken place the pushbutton LED (2.15) will go off..

RECALLING STORED POSITIONS

ATTENTION: before activating position recall, ensure that the assistant's tray does not interfere with the movements of the backrest.

WORK POSITIONS



- Press the Programme/STOP button (2.15) (LED on button lights).

- Within one second from pressing the Programme/STOP button press the button with the required position number (LED on button lights). The chair adopts the memorised position (at the end of the movement the two LEDs switch off).

- Any chair control key stops all automatic movements in progress.

N.W.: Also pressing the foot control lever (see chapter "FUNCTION OF PEDAL BOARD"), will call up one of the 4 memorised work programs.

RESET



- By pressing the Reset button (2.13 – pict. 2B) the memorised position is recalled (if the operating lamp is on it will switch off automatically). The position allows patients to get in and out of the chair with greater ease.

- Any chair control key stops the automatic movement in progress.

N.B.: It is also possible to use the foot control to recall the reset position (see "FOOT CONTROL FUNCTIONS" paragraph).

RINSE



- Press the Rinse button (2.14) (LED on button lights). This function moves the backrest only. The movement stops when the memorised position is reached (the LED remains lit)

- By pressing the button again (2.14) the backrest returns to the position it was in prior to the rinse movement (when the chair reaches the initial position the Led switches off).

- Any chair control key stops the automatic movement in progress.

SAFETY SYSTEMS: SELF-DIAGNOSIS AND AUTOMATIC LOCK

The chair is fitted with a self-diagnosis system for particular faults, with automatic lock and fault indication features.

When a key is pressed, if the self-diagnosis system detects a fault, the following error indications may appear:

| | INDICATION | REASON |
|-----------|---|---|
| 1) | <i>All leds flash except P/S.</i> | <i>Ophthalmic lock switch enabled or instrument enabled</i> |
| 2) | <i>Alternate flashing of backrest recline/upright leds</i> | <i>Assistant Tray handle switch enabled</i> |
| 3) | <i>Simultaneous flashing of backrest recline/upright leds</i> | <i>Backrest safety switch enabled</i> |
| 4) | <i>Simultaneous flashing of raise/lower leds</i> | <i>Chair safety switch enabled</i> |
| 5) | <i>Raise led flashes if the raise key is pressed</i> | <i>Raise chair limit stop</i> |
| 6) | <i>Lower led flashes if the lower key is pressed</i> | <i>Lower chair limit stop</i> |
| 7) | <i>Recline led flashes if the recline key is pressed</i> | <i>Backrest recline limit stop</i> |
| 8) | <i>Upright led flashes if the upright key is pressed</i> | <i>Backrest upright limit stop</i> |

AUTOSTERIL - TIME FLUSHING SYSTEM

* **AUTOSTERIL: system for decontaminating** dental unit waterlines with a timed flow of liquid containing a chemical agent that kills spores, viruses, fungi and bacteria, period of contact and rinse with mains water or dedicated liquid supplied from an independent reservoir

The result varies according to the length of exposure and the product used and is achieved at the end of the contact time. The final rinse removes product residues and leaves the last rinse liquid in the waterlines.

* **TIME-FLUSHING: sanitization** of dental unit waterlines with a system that flushes out the waterlines with the liquid selected for the instrument sprays (mains water or dedicated liquid supplied separately)

AUTOSTERIL and TIME FLUSHING are not designed to deliver liquids during treatment on patients. The cycles must be run while the equipment is not in use.

The section entitled "Products to be used with Castellini Dental Units" indicates the specific disinfectant product to be used for Autosteril cycles and the dedicated liquid for the Separate Supply system.



CAUTION:



Always check what kind of liquid is contained in the tank, both before carrying out decontamination cycles and resuming normal use

PREPARATION

Before carrying out Autosteril or Time-Flushing cycles:

- disconnect the Turbine, Micromotor, Scaler handpieces and open the flow regulators in the tubing terminals all the way
- insert the tubing terminals in their receptacles in the water delivery unit (Pict. 6)

CAUTION: to treat the internal tubing of the Syringe (THREESTERIL model only), place the ring provided over the water button. When flow from the other instruments stops, remove the ring to stop flow.

Note: the cycles may also be performed with the handpieces connected to the tubings, as long as care is taken to remove burrs, rotary instruments and Scaler tips before inserting to instruments in their receptacles

1 - AUTOSTERIL

Carry out the preparatory steps described above:

- position the liquid selection lever on H₂O (**2.8** - pict. 6)
- Prepare the disinfectant solution in the tank, following the manufacturer's directions. Then connect the tank to the fitting provided (see: "Separate Supply System")

- position the liquid selection lever (**2.8** - pict. 6) on



- press the start button (**2.18** - pict. 2B). Warning: make sure that the liquid is discharged from the instruments
 - when the flow of disinfectant stops (after about 1.5 minutes) **wait** until the planned contact time (5 or 10 minutes depending on the level of treatment desired) has lapsed
 - **rinse out the waterlines by carrying out a Time-Flushing cycle (see below)**
- Once the cycle is completed, lubricate the rotary instruments and run them for a few instants

2 – TIME-FLUSHING (sanitization or rinsing after Autosteril)

Carry out the preparatory steps described above or activate at the end of the Autosteril contact time:

2a) Time-Flushing (or Autosteril rinse) with mains water

- position the liquid selection lever on H₂O (**2.8** - pict. 6)



- press the start button (**2.18** - pict. 2B). Make sure that the liquid is discharged from the instruments
- when the flow stops (after about 1.5 minutes), reposition tubings and instruments on the handpiece holders

2b) Time-Flushing (or Autosteril rinse) with dedicated liquid

- position the liquid selection lever on H₂O (**2.8** - pict. 6)
- insert a bottle of dedicated liquid (see "Separate Supply System")
- position the liquid selection lever (**2.8** - pict. 6) on



- press the start button (**2.18** - pict. 2B). Make sure that the liquid is discharged from the instruments
- when flow stops, reposition the instruments on the handpiece holders

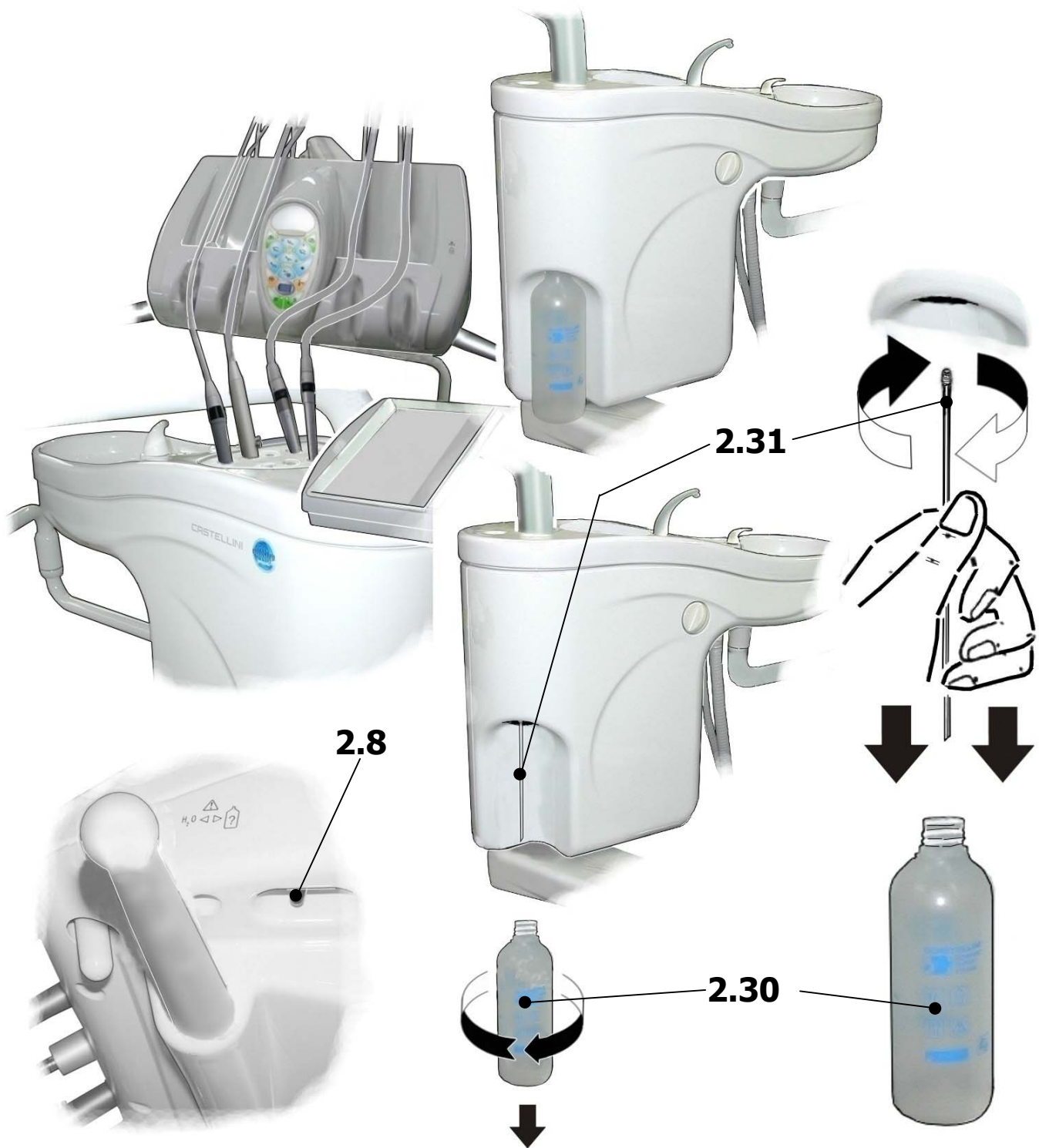

Pict. 6 – AUTOSTERIL - TIME FLUSHING SYSTEM

SEPARATE SUPPLY SYSTEM

The dental unit may supply the dental instrument sprays from two different sources:

- normal supply with mains WATER, provided that it is supplied by a system guaranteeing the physical separation between the water supply and instrument supply lines, in conformity with standard EN 1717
- Separate Supply from an independent tank, either sterilizable or disposable (**2.30** in Pict. 6);

We strongly suggest to supply always the instruments with dedicated liquid from the separate supplying system on the unit.

the tank and intake tube (**2.30** and **2.31** in Pict. 6) may be removed and sterilized in an autoclave at 135 °C, 210 kPa (2.1 bars) for 20 minutes. The tank is also used for Autosteril/Time Flushing depollution (see Autosteril/Time Flushing). For the separate supply, you may use a liquid poured into the tank provided or else Rinsing Agents in disposable containers which may be connected to the dental unit instead of the tank: Purified Water P.S. or Isotonic Saline Solution. Note: The Rinsing Agents allowed for use with the Separate Supply System are listed in the paragraph on "Products to be Used with the Castellini Dental Unit".

SELECTING THE SUPPLY SOURCE

The control for selecting the supply source is a lever on the side of the Dental Instrument table (**2.8** - Pict. 6)::

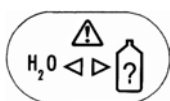

- lever positioned on H_2O = mains supply tap water
- lever positioned on: = separate supply from independent tank

FILLING / REPLACING THE LIQUID IN THE TANK

Separate sterilizable, reusable tank

- position the selector lever on H_2O :
- disconnect the sterilizable tank from its screw coupling by turning it anti clockwise
- remove the intake tube by turning it anti clockwise;
- sterilize the tank and tube in an autoclave for 20 min. at 135 °C - 210 kPa (2.1 bars)
- pour the liquid chosen into the sterilized tank
- wearing sterile gloves and avoiding all contact with surrounding surfaces, screw the sterilized tube back into place
- reconnect the tank, lifting it up around the intake tube, and screw it firmly into place.
- Shift the selector lever into position
- Replace the bottle at least once in a year



AUTOClaveABLE BOTTLE
CODE N5000096

Disposable container of Rinsing Agent

- position the selector lever on H_2O ;
- disconnect the tank or empty disposable container by turning it anti clockwise;
- remove the intake tube by turning it anti clockwise and sterilize it in an autoclave for 20 min at 135 °C - 210 kPa (2.1 bars);
- wearing sterile gloves and avoiding all contact with surrounding surfaces, screw the sterilized tube back into place
- open a new container of Rinsing Agent by removing the cap;
- directly connect the container, lifting it up around the intake tube, and screw it firmly into place.
- Shift the selector lever into pos H_2O .



PURIFIED WATER
1 Litre BOTTLE
CODE N500P064



SALINE SOLUTION
1 Litre BOTTLE 1
CODE N500P066

CAUTIONARY



WARNING:



before using the spray on the patient, check the type of liquid contained in the tank

After using Physiological Solution or Isotonic Saline Solution, immediately rinse out the circuits with a Simple flushing cycle (see Autosteril/Time-Flushing) or by running the sprays with tap water for a few seconds. Do not blend different products. Before pouring a new product into a tank:

- remove and rinse out the tank to eliminate residues of the previous product
- pour tap water into the tank and connect it back in place
- carry out a Time-Flushing cycle with the separate supply system (see paragraph on "Autosteril/Time Flushing") to rinse out the circuit
- remove and empty the tank, then fill it with the liquid chosen according to the directions provided. Alternatively, use disposable containers of a Rinsing Agent.

SUCTION SYSTEMS (optional)

ATTENTION: Suction system cannulas are not provided with the unit. We recommend the use of cannulas that conform to Directive 93/42 EEC, bearing a CE mark only.

Single-surgery type "S" suction

This type of suction requires the single-surgery suction motor housed in a special box and a kit composed of the following parts, mounted inside the unit:

- Air liquid separator for drainage of aspirated liquids(type CS1 DÜRR);
- Tube for blood ejector cannula;
- Tube for mist cannula;
- Filter for aspirated liquids.

Arrangement for type "C" centralised air suction

This arrangement requires a kit for the connection of the unit to a centralised suction system, composed of the following parts assembled inside the unit:

- Air liquid separator for drainage of aspirated liquids(type CS1 DÜRR);
- Pneumatic solenoid valve for suction selection;
- Tube for blood ejector cannula;
- Tube for mist cannula;
- Filter for aspirated liquids.

Arrangement for "LC"centralised liquid ring suction

This arrangement requires a kit for connecting the unit to a centralised suction system, composed of the following parts assembled inside the unit:

- Pneumatic solenoid valve for suction selection;
- Tube for blood ejector cannula;
- Tube for mist cannula;
- Filter for aspirated liquids.

Suction with "DÜRR COMBI CAS 1" amalgam separator device

The use of amalgam separator devices in single-surgery and centralised suction systems makes it possible to separate and collect amalgam residues in the liquid, as well as perform air/liquid separation.

The system is fitted with a highly efficient centrifuge amalgam separator, with separate treatment of the two types of drainage from the unit:

- 1) surgical suction drainage, consisting in a little water, approximately 100 ml/min with a high concentration of amalgam residues;
- 2) cuspidor drainage, consisting in a heavier water flow (3 l/min) with a low concentration of amalgam residues.

The system assures the separation of 95% of amalgam, in compliance with current international legislation.

"DÜRR CS1" type systems on the other hand are aspirated liquid/air separators and partial separators of the solid residues of amalgam present only in the liquids aspirated through the suction pipes.

All systems are provided subject to request and assembled inside the unit.

Arrangement for centralised mod. "DÜRR VSA" suction system

This arrangement includes the housing inside the unit body, of a kit of components for connection to a single-surgery or centralised suction system, composed of:

- pneumatic solenoid valve for selecting suction to the cannulas.
- collector for drainage liquids from cuspidor and cup, with solenoid valve for the activation of the aspiration system for the liquid drainage, and filter for the treatment of solid residues.

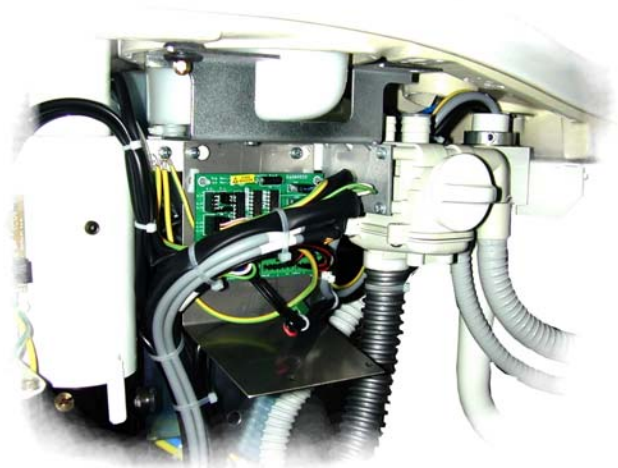

CENTRALISED "LC" SUCTION"

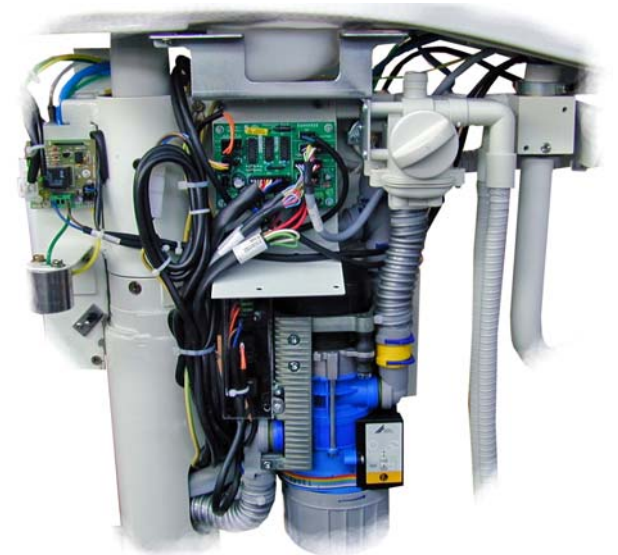

DÜRR COMBI CAS 1

CONVERSION OF THE "Puma Evo" UNIT FROM RIGHT-HANDED TO LEFT-HANDED CONFIGURATION
(only for ambidextrous dental units) (Picts. 9A, 9Abis, 9B, 9Bbis, 9C, 9D and 9E)

The ambidextrous version of the "Puma Evo" unit is fitted with a manual mechanical system for the transformation of work layouts for both right- and left-handed dentists. The operations required for the abovementioned conversion consists in 5 quick and easy steps that can be performed by surgery staff:

Step 1 – Positioning the unit and dismantling seat upholstery.

Position the chair approximately halfway up its height stroke and take the backrest to a completely upright position, then switch off the main switch. Dismantle the seat upholstery (9.1 - pict. 9A) by detaching the two rear Velcro fasteners and sliding it forward.

ATTENTION:

- remove the filler terminal on the cuspidor of the water delivery unit (Pict. 9A bis);
- It is recommended to remove the suction terminals from the assistant's tray and disconnect the corresponding tubes from the unit body in order to prevent hindrances during the conversion manoeuvre

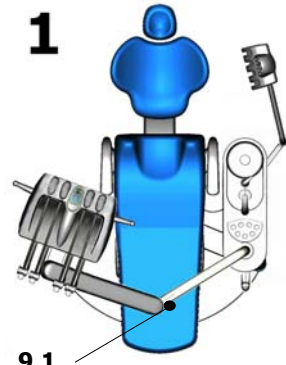

Pict. 9A - Step1

Step 2 – Releasing the unit.

Fold the front metal part of the seat (leg-rest) back toward the backrest (9.2 – pict. 9B). Disengage the anti-rotation stoppers by pulling the knobs (9.4 and 9.5) and, at the same time, exerting a partial rotation of the arm (9.3) and unit body in order to keep the pins unlocked.



Pict. 9A bis – Disassembling the filler

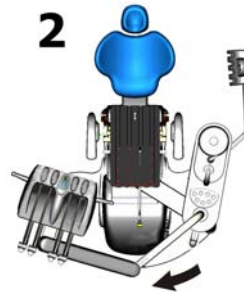

Pict. 9B - Step 2

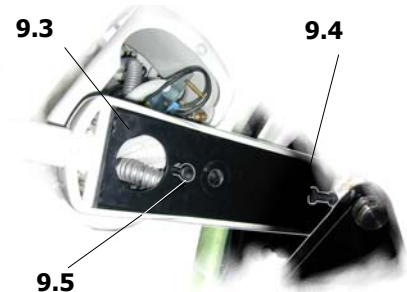

Pict. 9B bis – Stopper releasing

3

Step 3 – Instrument tray rotation.

Position yourself in the centre of the chair and pull the unit body towards you. When the unit body is halfway along the chair, take the instrument tray to the opposite side to the plumbing unit taking care to keep the arms in to avoid the unit from toppling over. (see pict. 9C).

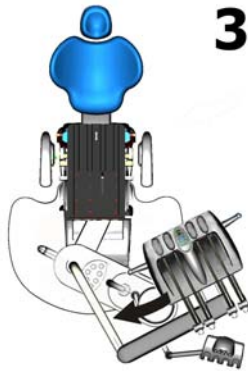

Pict. 9C - Step 3

Step 4 – Rotating and locking the plumbing unit.

Complete the rotation of the unit body taking it to the end of its stroke (Pict. 9D) and ensure that the stopper pins (9.4 and 9.5) are inserted into their seats. The pivot of hydric (9.5) return automatically into their seat rotating the group up to the maximum opening towards the outside. Reposition the suction terminals in their seats and then insert the connectors at the other end of the tubes into the plumbing unit body.

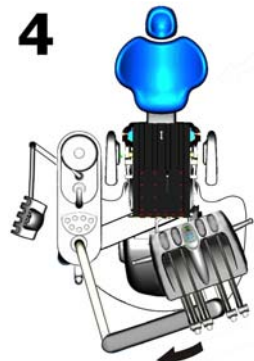

Pict. 9D - Step 4

Step 5 – Assembling chair upholstery and positioning trays.

Rotate the instrument tray taking it to a position in which it will not hinder the reassembly of the seat upholstery, and then fold the front part of the seat (legrest) outwards. Reassemble the seat upholstery (Pict. 9E) repeating the operations indicated in Step 1 in reverse order. Fit the cup filler back in place. Reposition the dentist's and assistant's instrument trays in the respective working areas.

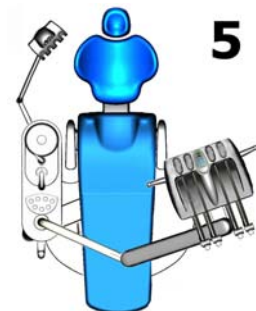

Pict. 9E - Step 5

DISINFECTION AND STERILIZATION

Procedures and program for sanitizing the equipment

ATTENTION: Always wear protective gloves when performing cleaning and disinfecting operations.

The products that can be employed with the unit are listed in the "Products for use with dental unit" paragraph and must be used according to product instructions.

Upholstery – cleaning: For a protective, sanitising cleansing treatment use "*ST-Surface Treatment Castellini*": apply directly on the surface to be treated and spread evenly with a soft cloth. Then remove residues with a dry cloth.

Surfaces – cleaning:
 - disinfection: - Clean and decontaminate with Castellini **STER 1 PLUS**.
 - Disinfect using ethyl alcohol 70% apply using a cloth, rub in until absorption.

- WATERLINES SUPPLYING SPRAYS

- cleaning: Flushing - Time Flushing with mains water (see Chap. on Autosteril / Time Flushing)

- decontamination: Autosteril cycle with chemical sterilant (see Chap. on Autosteril / Time Flushing).

- **Flexible shields** Inside tray, handpiece rests, Autosteril/Time Flushing holders:

- cleaning: - clean and decontaminate with **STER 1 PLUS** Castellini according to the instructions provided.

WARNING: contact with silicone materials for interocclusal records may cause irreparable damage to flexible shields and instrument cords

- disinfection: - disinfect using ethyl alcohol 70%
 - in an autoclave with steam for 20 min at 135 °C - 210 kPa (2.1 bars)

- sterilization: - *to bleach flexible protections*

- maintenance: - prepare a solution with 0.1÷ 0.5 % Active Chlorine, such as **AMUCHINA** Chlorine Oxidant diluted 10% in water or commercial Bleach diluted 10 % in water;

- Allow the parts to be bleached to soak for 1 – 2 hours;

- Remove and rinse thoroughly.

Note: immediately after treatment the part may become temporarily darkened but after a few hours of exposure to the air it will spontaneously regain its natural surface color.

This treatment also has a disinfectant effect.

WARNING: In contact with acids, the liquid releases a toxic gas (Chlorine). Irritant. Rinse the treated materials thoroughly before reusing them

Ceramic bowl

- cleaning: - domestic scale removing cleanser applied with a soft sponge (non-abrasive);

- Tray handles

Tank and hose for separate supply

Cover of Autosteril tub

- cleaning: - cleaning and sanitizing with **STER 1 PLUS** Castellini

- disinfection: - disinfect using ethyl alcohol 70% vol.

- sterilization: - in an autoclave with steam for 20 min at 135 °C - 210 kPa (2.1 bars)

- Compressed air filter ampoules (General air filter and HPA filter)

- cleaning: - clean with a neutral liquid detergent (e.g. neutral Shampoo) and warm water.

WARNING: THE MATERIAL OF THE AMPOULES IS NOT ALCOHOL RESISTANT!

- HPA filtering cartridge for compressed air

- sterilization: - in an autoclave with steam for 20 min at 135 °C - 210 kPa (2.1 bars)

SURGICAL SUCTION SYSTEM**- Suction tubes**

- cleaning and sanitizing: - aspirate the diluted solution of **STER 3 PLUS**, according to the instructions provided; then replace the disposable cannulas or rinse out and sterilize the reusable cannulas.

- Cannulas connectors

- cleaning: - Clean and decontaminate using Castellini **STER 1 PLUS**.
- disinfection: - Disinfect using ethyl alcohol 70% vol.
- sterilization: - The cannula connectors are disconnected from their respective hoses and sterilised in a steam autoclave for 20 min at 135° C – 210 kPa (2.1 bar)

- Suction system filter

- cleaning: - clean and sanitize the CONDUITS (see "**Suction tubes**");
- activate the suction system by raising a cannula;
- while the suction is on, remove the pressure plug (**13.2** – Pict. 13);
- dispose of the residues and wash the filter under running water.

OPERATING LIGHT:**INSTRUMENTS:**

- see the instructions for each instrument in Parts "**LUNA**" *operating lamp* and *Operating Instruments* – in this manual.

EQUIPMENT SANITIZATION SCHEDULE

START OF THE WORKING DAY

- ◆ **TIME-FLUSHING** cycle, simple flushing with tap water;
- ◆ Application of sterilized Flexible Protections;
- ◆ Application of disposable covers for the Chair and Dental Unit;
- ◆ Insertion of **VF CONTROL PLUS** tablet in the filter of the suction system.



VF CONTROL PLUS
 Package containing 120 Tablets CODE N500PP80
 Package containing 240 Tablets CODE N500PP79

AFTER EACH PATIENT

- ◆ **AUTOSTERIL** waterline decontamination cycle
- ◆ Sterilization of sterilizable instruments (lubrication of Turbines and Micro-motor handpiece before and after treatment with **DAILY OIL**)
- ◆ Sterilization of Flexible Shields
- ◆ Cleaning of suction hoses with **STER 3 PLUS** (3 measuring capfuls in 1 litre of hot water)
- ◆ Cleaning and disinfecting of contaminated surfaces with **STER 1 PLUS and ETHYL ALCOHOL 70%**
- ◆ Change of disposable covers



DAILY OIL
 SPRAY W/ QUICK COUPLING CODE L0000945
 SPRAY W/ QUICK COUPLING CODE L0000946
 SPRAY WITH SCREW CONNECTION CODE L0000950
 SPRAY WITH SCREW CONNECTION CODE L0000951



STER 1 PLUS
 1 Lt CODE N500P089
 Package with six 1Lt Bottles CODE L0000813

END OF THE WORKING DAY

- ◆ **AUTOSTERIL** waterline decontamination cycle
- ◆ Sterilization of sterilizable instruments (lubrication of Turbines and Micro-motor handpiece before and after treatment with **DAILY OIL**)
- ◆ Sterilization of Flexible Shields
- ◆ Sterilization of Separate Supply Tank
- ◆ Elimination of disposable covers
- ◆ Clean and disinfect contaminated surfaces with **STER 1 PLUS and ETHYL ALCOHOL 70%**
- ◆ Sanitizing protective detergent of Dental Chair surfaces and Stool Upholstery use **ST-Surface Treatment**
- ◆ Cleaning of surgical suction CONDUITS with **STER 3 PLUS** (3 measuring caps in 1 liter of hot water)
- ◆ Cleaning of Suction System FILTER
- ◆ Cleaning of cuspidor drain FILTER
- ◆ Sterilisation of cuspidor water spout, cup filler, cuspidor, dentist's tray handles and handpiece protection (all removable and autoclaveable)



STER 3 PLUS
 1 Lt CODE N500P071
 Package with six 1Lt Bottles CODE L0001293



ST-Surface Treatment
 Bottle 400 ml
 CODE N500P150



MONTHLY

- ◆ Replace cartridge of **HPA FILTER** (if present)
- ◆ Cleaning of **AMALGAM SEPARATOR** filter (if present)
- ◆ Note: see instructions for replacing the amalgam collector;
- ◆ Cleaning of **GLASS FRONT** and **REFLECTING MIRROR** of the Operating Light.



cartridge HPA
 CODE H4200025

ROUTINE MAINTENANCE

procedures and maintenance to be performed by Dental Surgery Personnel

Routine checks and maintenance ensure that the equipment preserves its functional and safety features and are the user's responsibility.

In addition to routine maintenance, periodic scheduled maintenance must be performed by a Castellini Service Center, which must be called by the user at the intervals indicated in the Chapter on Schedule Technical Maintenance.

PROCEDURES

CHECK ON CRUSH-PREVENTION SYSTEMS (Pict. 10)

1 - Check on chair lowering anti-crush safety system (Pict. 10A - 1)

- Activate the chair lowering control and simultaneously press the safety base plate; the chair should come to an immediate stop and rise a few centimetres

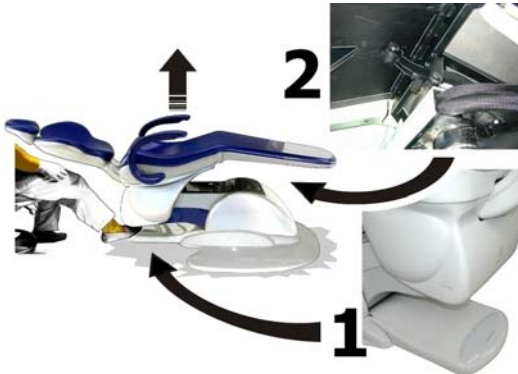

Pict. 10A – Chair lowering anti-crush safety system

2 - Check on backrest reclining anti-crush safety system (Pict. 10A - 2)

- Activate the backrest recline control and simultaneously block its way; the backrest should immediately stop moving



Pict. 10B – Assistant's tray anti-crush system

3 - Check on Assistant's Tray anti-crush system (Pict. 10B)

- Activate the backrest raising control and simultaneously lift the handle of the assistant's tray; the backrest should come to an immediate halt and move down a few centimetres

Should any of these systems fail to perform efficiently, contact the Castellini Service Dept.

GENERAL AIR FILTER (Pict. 11)

Il Filtro generale dell'aria ha la funzione di trattenere le polveri e separare la condensa dell'alimentazione pneumatica. Il livello del liquido condensato non deve raggiungere l'elemento filtrante (11.1).

Per scaricare la condensa:

- portare la poltrona all'altezza massima;
- spegnere il riunito con l'interruttore generale;
- porre un recipiente sotto il filtro;
- svitare la valvola di scarico (11.2) e scaricare la condensa.

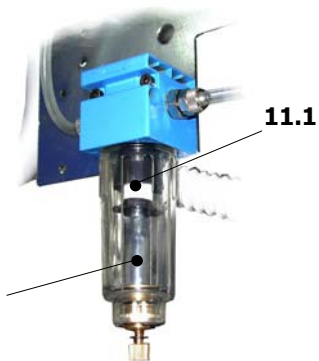

Pict. 11 – General air filter

ATTENZIONE: l'ampolla trasparente NON RESISTE ALL'ALCOOL!

SOSTITUIRE l'elemento filtrante una volta all'anno
(chiamare l'Assistenza Tecnica).

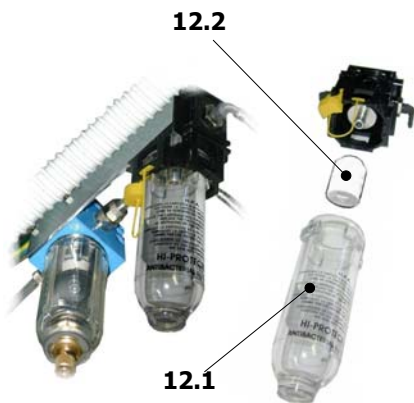

Pict. 12 – HPA filter

HPA FILTER (Optional) (Pict. 12)

The HPA filter has the function of trapping air-borne bacteria. The internal cartridge is autoclaveable:

- raise the chair to max. height;
- shut off the main switch of the dental unit;
- operate the syringe to release the air pressure;
- unscrew the transparent ampoule with your hands; (11.1)
- pull out the cartridge (11.2) and sterilize it in an autoclave at 135 °C 210 kPa (2.1 bars) for 20 min.

DO NOT USE DRY STERILIZERS.

- re-insert the sterilized cartridge by applying pressure and screw the ampoule back in place, tightening it all the way.

WARNING: the ampoule is NOT ALCOHOL RESISTANT!

REPLACE the cartridge once a year.

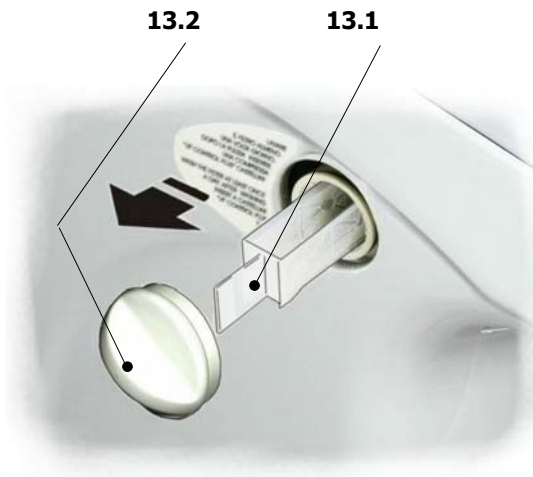

SUCTION SYSTEM FILTER (Pict. 13)

Keep the suction filter (13.1) clean and free of residues according to the cleaning directions provided in the chap. on Cleaning, Disinfection and Sterilization.

After cleaning, place one or two VF Control plus - sanitizing antifoaming tablets inside the filter.

CAUTION: wear protective gloves
Always operate with the suction system on (tube raised).

Pict. 13 - Suction system filter

WATER FILTERS (Pict. 15A)

- (under responsibility of dental surgery personnel)

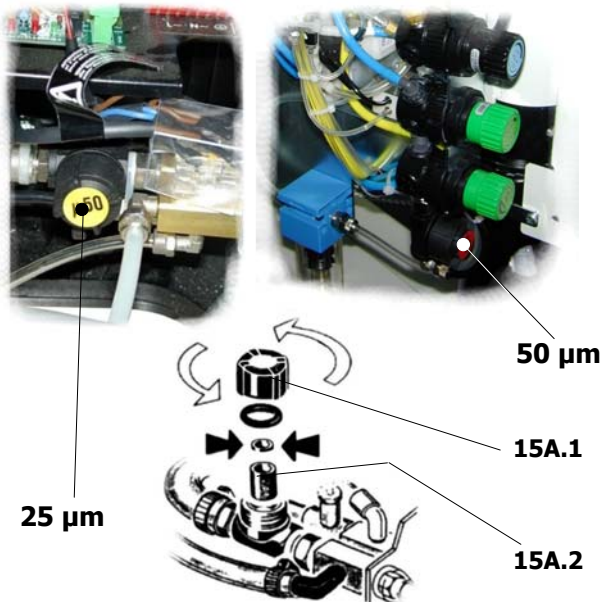

Each dental unit has two water filters: a general filter in the base of the chair (50 µm, with a **yellow** label), and a filter for the instruments in the Water Supply Unit (25 µm, with a **red** label).

In the event of a decrease in pressure or in water flow and in any case at least once a year, clean or replace the filtering elements:

- shut off the water supply to the dental unit
- shut off the main switch of the dental unit
- use the syringe to release residual pressure
- unscrew the cap (15A.1) and take out the filtering element (15A.2)
- replace the filtering element or clean it with either compressed air or water.

Pict. 15A – Water filters

WATER FILTER FOR HANDPIECES SPRAY (Pict. 15B)

In the inner part of the holder–instruments table is placed a water filter for the spray liquids of the operating instruments (about 50µm).

In case of pressure or water flow reduction of sprays to the handpieces, **and once at six months** thereafter, clean or substitute the filtering element:

- stop the hydric power of the unit;
- close the main switch;
- activate the syringe to discharge the remaining pressure;
- unscrew the cap (15B.1) and pull out the filtering element (15B.2);
- substitute the filtering element or clean it with compressed air or water.

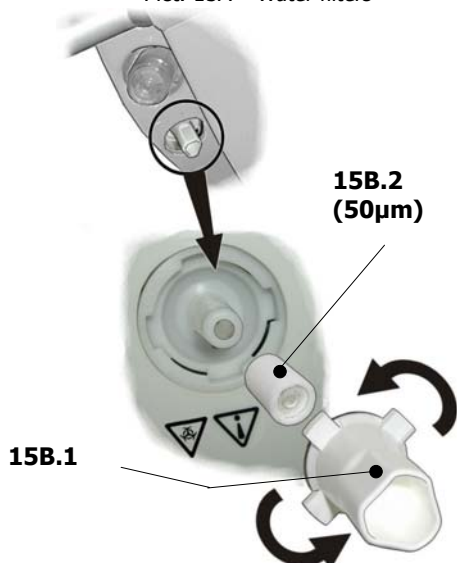

Pict. 15B – Water filter for handpieces spray



Pict 15C - Turbine condensation filter

TURBINE CONDENSATION FILTER (Pict. 15C)

Should you observe a significant increase in the build up of condensation inside the filter (15C.1 – Pict. 15C) situated beneath the dental unit instrument tray, remove the cover (15C.2) by turning it clockwise about a ¼ of a turn, replace the filtering element (15C.3) and eliminate the liquids present.



The filtering element must be replaced for the first time within a year of the date shown on the cover and at least once a year thereafter.



WARNING DANGER OF BACTERIAL CONTAMINATION!

The liquid condensate inside the cover must be handled and disposed of by personnel wearing disposable gloves and eye protection and always in compliance with Sanitary Regulations for the disposal of Waste associated with a High Biological Hazard.

LUBRICATION OF SEALS



Pict. 16A - Lubrication of seals

Use protective paste: "S1 Castellini – Protettivo per O-ring" (Pict. 16A).

Directions: wear protective gloves, apply small quantities of paste on your fingertips and spread a fine layer of paste over the part to be lubricated directly with your fingers.

SUCTION FILTER CAP (Pict. 16B)

Clean and sanitize the conduits with **STER 3 PLUS** according to the directions provided

- raise a tube to keep the suction system on;
- take off the filter cap (13.2 - Pict. 13);
- lubricate the inner surface of the cap as shown in the picture;
- fit the cap back onto the filter;

CAUTION: wear protective gloves

ALWAYS OPERATE WITH THE SUCTION SYSTEM ON (TUBE RAISED).



Pict. 16B - Suction filter cap

SUCTION CANNULA HOSE CONNECTION (Picts. 16C – 16D)

- raise a cannula to maintain suction
- remove the cannula body from its hose connection
- lubricate the O-Ring shown by arrow A
- lubricate the (red) (B) gasket by Vaseline
- insert a VF Control plus tablet inside the hose connection before fitting each cannula back in place

WARNING: wear protective gloves. always perform this operation with the suction on (cannula raised).

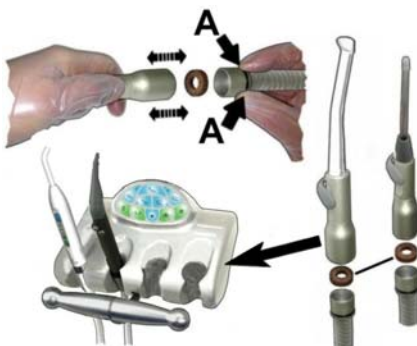

Pict. 16C – Suction cannula hose connection

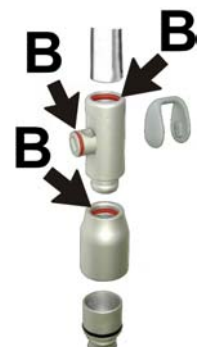

Pict. 16D – Suction cannula body connection

DENTAL INSTRUMENTS

see specific instructions in Part - Operating Instruments- of this manual.

OPERATING LIGHT

see the specific instructions in Part – Operating Lamp- of this manual.

ROUTINE MAINTENANCE PROGRAM

The manufacturer notes that all routine maintenance and sanitation of the dental unit must be performed EXCLUSIVELY with the products (lubricants included) specified by Castellini. It is forbidden to use any products other than those explicitly named in this manual and in the "Protocol for Hygiene and Maintenance of the Dental Unit".

The Manufacturer warns that any failure to comply with the above prescription will be considered improper use in contradiction with the manufacturer's directions and as a result will compromise the essential safety requisites.

DAILY

- ◆ Lubricate TURBINE with **DAILY OIL**
- ◆ Lubricate MICRO-MOTOR HANDPIECE according to the handpiece manufacturer's directions
- ◆ Lubricate AIR MICRO-MOTOR with **DAILY OIL**
- ◆ Lubricate FILTER CAP of the Suction System with protective paste **S1 – Protettivo per O-Ring**
- ◆ Empty out condensation from GENERAL AIR FILTER

Note: the Turbine, Micro-motor handpiece and Air Micro-motor must also be lubricated before and after autoclave sterilization cycles



DAILY OIL

SPRAY W/ QUICK COUPLING
CODE L0000945
SPRAY W/QUICK COUPLING
CODE L0000946
SPRAY WITH SCREW CONNECTION
CODE L0000950
SPRAY WITH SCREW CONNECTION
CODE L0000951

WEEKLY

- With **S1 – Protective for O-Ring, lubricate**
- ◆ O-Ring of quick coupling of TURBINE (if present)
 - ◆ O-Ring of coupling of MICRO-MOTOR HANDPIECE
- Connectors of internal section of SYRINGE

With **Vaseline, lubricate**

Red gaskets



PROTECTIVE PASTE S1

50 g CODE N500LP89

MONTHLY

- ◆ Check CRUSH-PREVENTION SAFETY systems of the Chair.

YEARLY

- ◆ Replace filtering element of GENERAL AIR FILTER
- ◆ Replace cartridge of **HPA** FILTER (if present)
- ◆ Replace the (separate supply system) bottle at least once in a year
- ◆ **CONTACT SERVICE CENTER for Scheduled Technical Maintenance**

PRODUCTS TO BE USED WITH THE CASTELLINI DENTAL UNIT

RINSING AGENTS FOR SEPARATE SUPPLY SYSTEM



- * **ISOTONIC SALINE SOLUTION** - OGNA S.p.A. 1000 ml disposable bottle to be connected to dental unit.
- * **PURIFIED SOLUTION P.S.** - OGNA S.p.A. 1000 ml disposable bottle to be connected to dental unit.
- * **PHYSIOLOGICAL SOLUTION** – Pharmaceutical product that may be used in the separate supply tank following sterilization of the latter in an autoclave.

PRODUCTS FOR AUTOSTERIL SYSTEMS



- * **Ster4Spray** - Chemical Powder Sterilizer.

USE FOR AUTOSTERIL: in solution, following the indications on the label (16 – 20 grams of product in 1 litre of hot water 35 - 40 °C). The solution must be used after 15 minutes and within 24 hours.

Disinfecting efficacy at different contact times: **2 minutes** (low), **5 minutes** (intermediate) **10 minutes** (high)

ATTENTION: Do not use the solution to supply instrument sprays.



Ster4Spray
200 g CODE N500P140

PRODUCTS FOR SANITIZING THE MEDICAL DEVICE

- * **ETHYL ALCOHOL AT 70%** - Solution 70 % (70 parts Ethyl Alcohol + 30 parts Distilled Water)

To be prepared on the spot by the user.

Note: in the "Guidelines of Conduct for Health Personnel for Controlling HIV infections", Ministry of Health 6 April 1989, this substance is listed among the high-grade disinfectants effective against the HIV virus: "Ethyl Alcohol and Isopropyl Alcohol (...) deactivate HIV in a few minutes. They are not effective on bacterial spores. Alcohol is most effective at a concentration of 70%: higher or lower concentrations are less effective".

- * **STER 1 PLUS Castellini** – Decontaminant for surfaces of Castellini Medical Devices for dentistry. 1000 ml bottle
- * **STER 3 PLUS Castellini** – Concentrated sanitizing liquid for cleaning the Surgical Suction System - 1000 ml bottle
- * **ST-Surface Treatment Castellini** – Sanitizing protective detergent for Dental Chair and Stool Upholstery – 400 ml bottle
- * **VF CONTROL PLUS Castellini** – Sanitizing anti-foaming tablet for surgical suction circuits
Formats SMALL (240 1.7 g tablets) and MAGNUM (120 2.4 g tablets) - Use: in the suction system filter and in each suction cannula.
- * **AUTOCLAVEABLE TANK** for separate supply system
- * **PROTECTIVE SHIELDS:**
Disposable covers for Chair headrest, backrest and seat
Disposable adhesive cover for Control Panel
Flexible autoclaveable shields for Instrument Tray, Handpiece Holder, Autosteril receptacles

PRODUCTS FOR MAINTENANCE

- * **DAILY OIL Castellini** – Lubricating spray for daily turbine maintenance - Format: 200 ml cylinder
- * **S1 Castellini - Protettivo per O-Ring** – Protective silicone paste - Format: 20 g. tube
- * commercial **VASELINE**
- * **SODIUM HYPOCHLORITE 5 ÷6% of Active Chlorine (commercial bleach) – DILUTED BEFORE USE**
USE: to bleach flexible shields, 10% solution to be prepared by user on the spot (1 part bleach + 9 parts water)
- * **AMUCHINA Electrolytic Chlorine Oxidizer – DILUTED BEFORE USE**
USE: to bleach flexible shields, 10% solution to be prepared by user on the spot (1 part bleach + 9 parts water)



Puma Evo

PART II – OPERATING LAMP “LUNA”

TECHNICAL DATA

MEDICAL DEVICE CLASS I - by 93/42 EEC Directive

ELECTRO-MEDICAL EQUIPMENT CLASS I TYPE B - By CEI EN 60601-1

THE EQUIPMENT CANNOT BE USED WHEN FLAMMABLE ANESTHETIC MIXTURES CONTAINING AIR OR OXIGEN OR NITROUS OXIDE ARE PRESENT

POWER SUPPLY

| | |
|---|-------------|
| MAXIMUM POWER INPUT | 75 W |
| VOLTAGE TO THE BULB | 12 V DC |
| HALOGEN BULB WITH AXIAL FILAMENT (OSRAM HALO STAR 64450S) | 12 V - 75 W |

CONTINUOUS OPERATION

continuous

LIGHTING PARAMETER

| | |
|-------------------------------------|------------|
| LIGHTING AT 70 cm (I position) | 20000 lux |
| COLOR POINT PROJECTION at 20000 lux | 4000 K |
| LIGHT PROJECTION at 70 cm | 20 X 10 cm |

OPERATING LIGHT RANGE

| | |
|---|-------|
| VERTICAL TRANSLATION (to the "Y" axis) | 87 cm |
| "X" AXIS ROTATION | 280° |
| "Z" AXIS ROTATION | 60° |
| "Y" AXIS ROTATION | 120° |
| ARTICULATED ARM ROTATION AS TO SUPPORT POLE | 350° |
| SUPPORT POLE ROTATION AS TO THE UNIT | 140° |

MAXIMUM WHOLE WEIGHT

| | |
|--------------|-------|
| UNIT VERSION | 13 kg |
|--------------|-------|

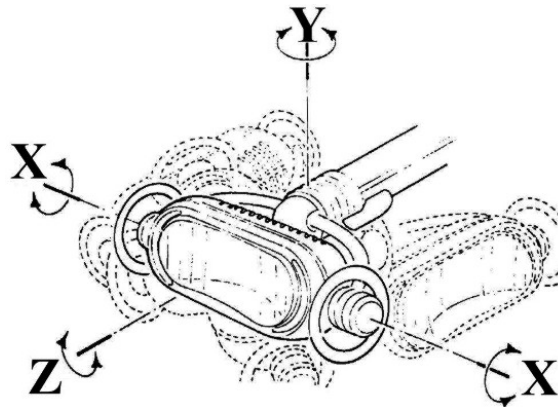

Operating light head rotation axes

PICTURES AND DESCRIPTIONS

(Pict. 1)

- 1 - Operating handle
- 2 - Operating light head
- 3 - Self-balanced pantograph arm

Warning!

- Do not use the lamp if the front glass or the external head casing are visibly damaged or if unusual noises and/or vibrations are produced. Contact an authorised technical service centre.
- For the movement of the light use the handles (1.1) only.



Pict. 1 - "LUNA" operating lamp"

REPLACEMENT OF THE BULB

(12 V - 75 W HALOGEN type HALO STAR 64450S OSRAM) - (Pict. 2)

Before executing this operation, it's necessary to take away the electric current from the unit:

- Bring the head (1.2 – pict. 1) in an accessible position for the operator, and orientate it up, as shown in the picture.
- Wait some minutes for the frontal glass cooling and hold it by hand, unscrewing the fixing screws (2.1) as to whole loosening: these screws go down without fall.
- After taking away the frontal glass, wait some minutes, and then be sure that the internal parts are cold to make any operations, because the whole lighting group reaches high temperatures during the operation.
- Unthread the lighting cover (2.3) from its guide (2.4), loosen the security dowels (2.5), using the hexagon wrench supplied, and take away the halogen bulb (2.6).
- Replace the old bulb with an identical one **avoiding to touch with the fingers the new bulb for not shorten the lenght** (to insert it into the bulb support, use, for protection, the plastic case of the wrapping).
- Screw the security dowels (2.5) and take away the plastic case.
- After inserting again the lighting cover (2.3) in its guide (2.4), mount the frontal glass in its side and screw the fixing screws (2.1), keeping it by a hand.

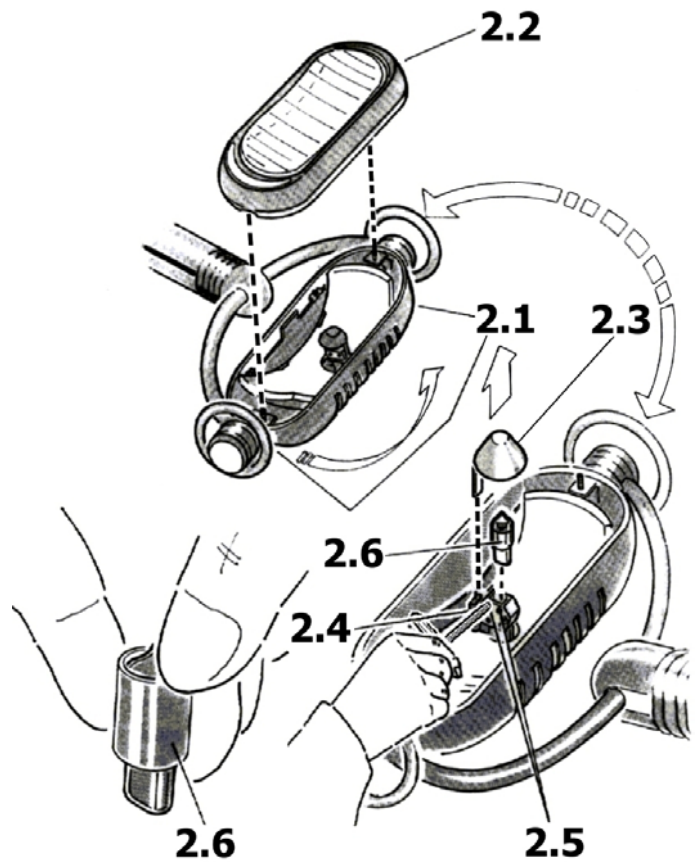

Pict. 2 - Replacement of the bulb

FOCUSING OF THE "LUNA" OPERATING LIGHT

(Pict. 3)

The focusing of the "Luna" operating light (Pict. 3), is carried out by Castellini S.p.A, and the replacement of the bulb **doesn't** modify it;

In case of necessity, operate as follow:

-Switch on and rotate the operating light head to the floor and project the lighted beam perpendicularly upon a white drawing sheet 70 cm about far from the frontal glass.

-By means of a screwdriver adjust screws (3.1 - 3.2 - 3.3), which are accessible through the back slots, so as to the lighted image becoming a rectangular pattern 20 x 10 cm about.

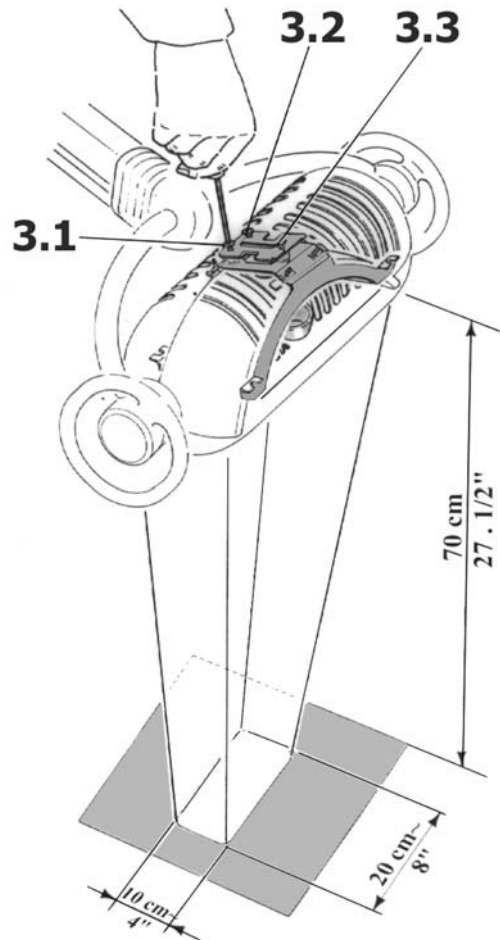

Pict. 3 – Focusing of the operating light

CLEANING OF THE OPTICAL PARTS

Clean periodically the mirror and the frontal glass to prevent any luminosity level dropping.

This operation must be carried out when head is cold.

Use only ethyl denatured alcohol.

Dry surfaces carefully before switching on the operating light.

PANTOGRAPH ARM REGULATION

(Pict. 4)

Whenever the head wouldn't stay in the position you desired, it would be necessary to repeat the regulation of pantographed arm self-balancement:

- Do place the head as shown in the picture.
- Unthread along the self-balanced arm the 2 rubber foldings (4.1).
- Unscrew and take away the 4 fixing screws (4.2) and remove the arm covering (4.3).
- Screwing coupling box (4.4, with a screwdriver or a pin) you shall increase it's spring tension; unscrewing coupling box, you'll decrease spring tension.
- Finally, you have to replace both arm covering that rubber foldings.

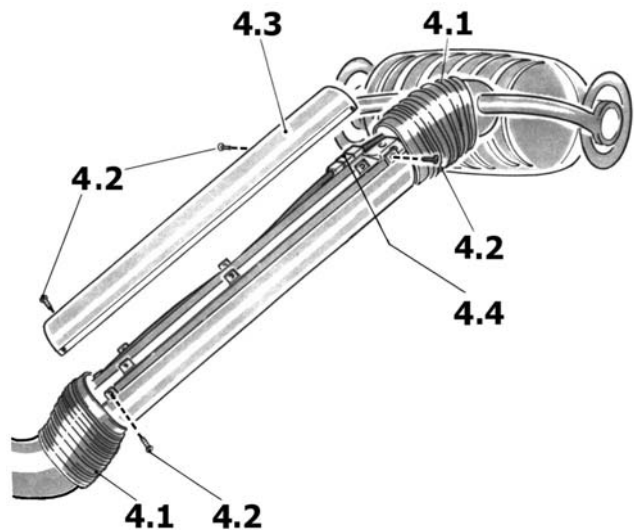

Pict. 4 - Pantograph arm regulation

"LUNA" operating light

versione applicata al riunito
 an dem Anlage aufgesetzte Ausführung
 modelo aplicado a l'equipo dental

unit body fitting version
 version appliqué a l'unit
 behandelunitversie

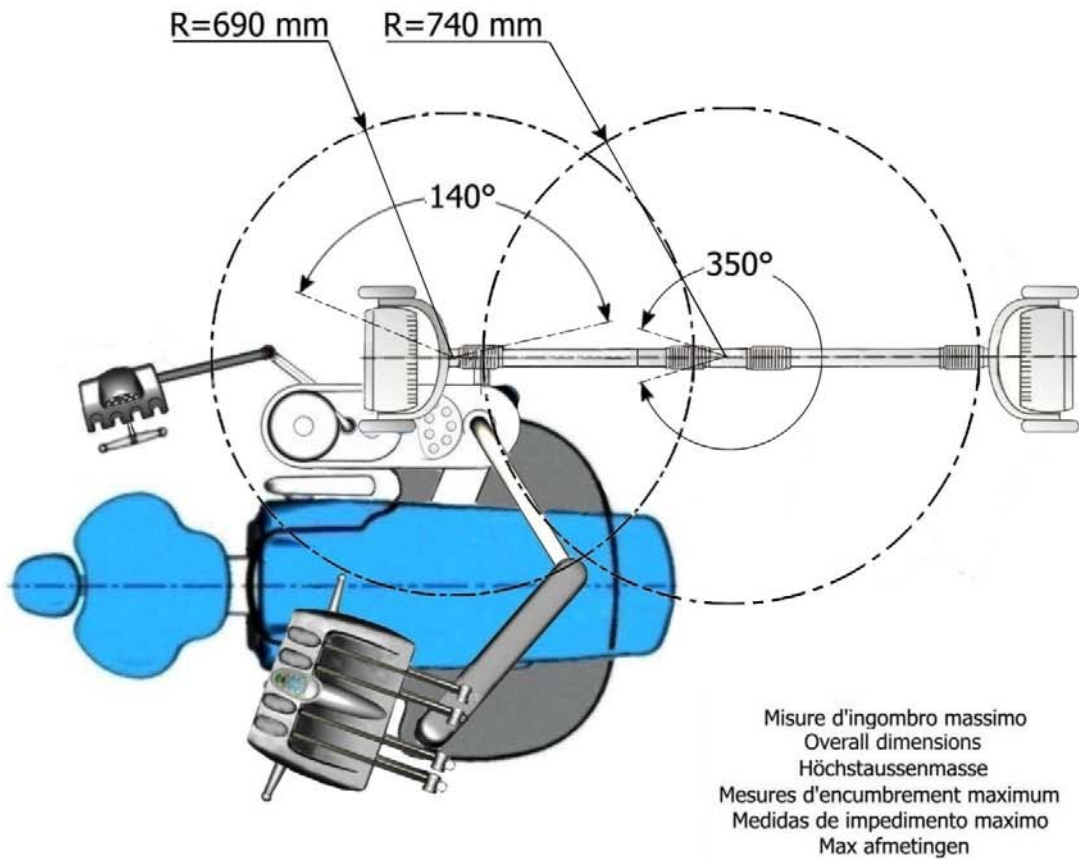
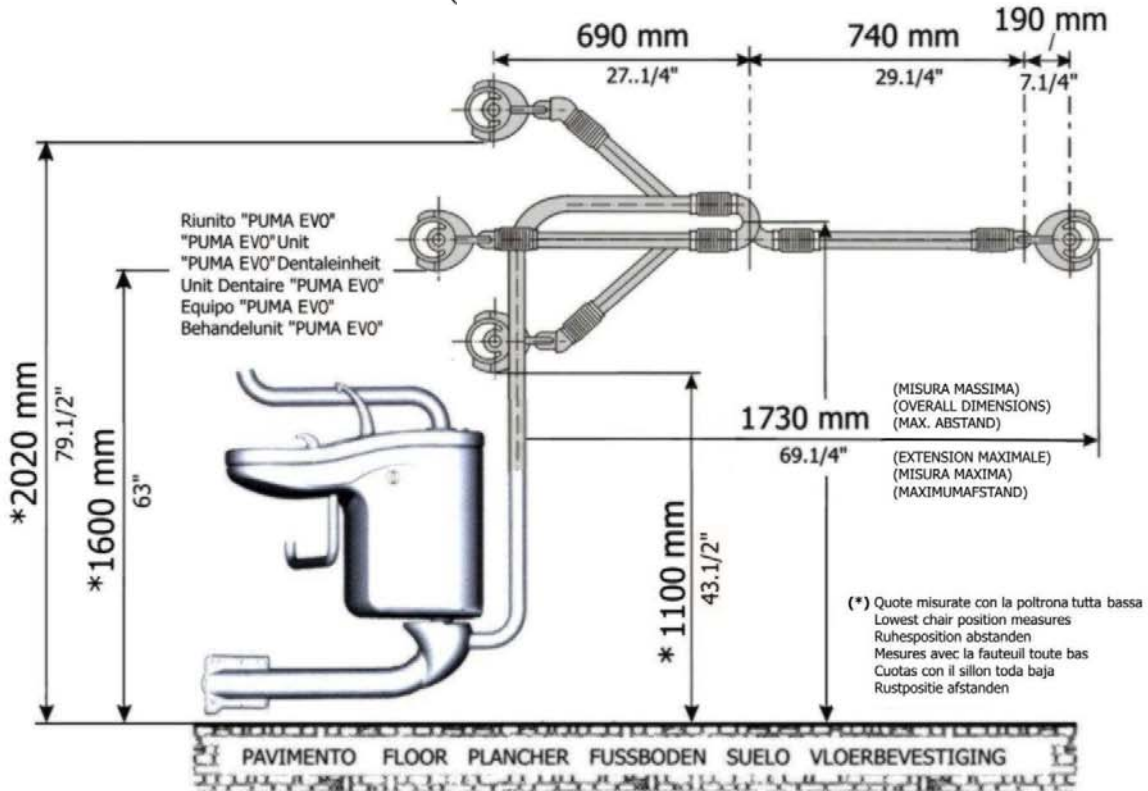

PAGE WITHOUT TEXT



Puma Evo

***PART III* – OPERATING INSTRUMENTS**

"THREESTERIL" SYRINGE

GENERAL SPECIFICATION

The Threesteril syringe is available just in the three ways (cold) model. It allows supply of either water, air or spray (i.e. water and air simultaneously) by pressing control **A (water)**, **B (air)** or **A and B together (spray effect)**. pict. 1. Air supply may be adjusted according to the pressure applied on control B. The nozzle may be rotated.

Warning!

Before every use, check that the nozzle and the external casing are correctly fitted onto the syringe body.

Do not use the instrument if it is visibly damaged. Contact an authorised technical service centre.

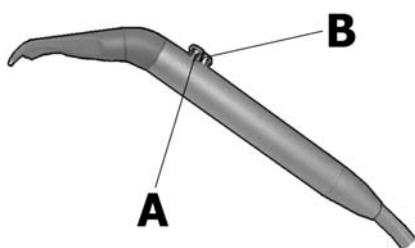

Pict. 1 – Overall view

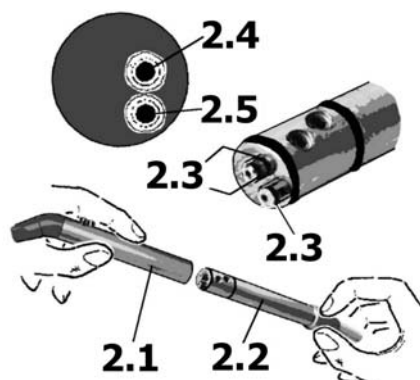

Pict. 2 – Connection to the unit

CONNECTION TO THE UNIT

The inner body of the Threesteril syringe is already connected to the unit. Fit the outside body paying attention not to press A and B controls (Pict. 1) and rotating slowly into the position that allows a complete fitting until it clicks.

The dental equipment has been set by Castellini S.p.A. to supply water and air with correct pressure for the syringe:

air pressure: min: 330 kPa (3.3 bar) - max: 460 kPa (4.6 bar)
measured in position (2.5 - pict. 2)

water pressure min: 90 kPa (0.9 bar) - max: 140 kPa (1.4 bar)
measured in position (2.4 - pict. 2)

Do not exceed in any case these pressure ranges.

USING SAFELY: rules and recommendations

To ensure that the equipment is used safely, the user must abide by the set standards of hygiene and professional diligence.

The following points should also be kept in mind:

- During use, dust and fragments of material from the patient's mouth or the device being used may be thrust into the surrounding environment (organic and inorganic particles, metal dust, liquids, potentially infected fluids and biological materials):

PERSONNEL MUST DULY PROTECT THEIR EYES, BREATHING PASSAGES, MOUTH AND SKIN by wearing safety glasses, face shields, masks and disposable gloves.

Operate the suction system at high speed in all operations likely to result in a discharge of materials, dust and aerosols to minimise their dissemination.

N.B.: it is not advisable to use drinking water to supply the dental unit, since it may lead to the formation of a biofilm in the waterlines and thus facilitate germ proliferation inside the unit itself.

It is recommended to supply the unit exclusively with dedicated liquids (Isotonic Saline Solution or I.P.Purified Water) using the Separate Supply system.

SERVICING

It is indispensable to supply the syringe with air and water conveniently filtered. Regular maintenance of the filters in the unit and draining the condensate from the compressor tank is therefore recommended.

Grease O-rings (2.3 - pict. 2) with silicon lubricant S1 once a week. Wearing protective disposable gloves, apply a small amount of S1 on fingers and lubricate by it.

CLEANING, DISINFECTING, STERILIZING

Warning! The instrument is supplied not sterile.

Before use sterilize according to the above specifications.

Use gauze or cotton soaked in surgical alcohol to clean and disinfect syringe exterior.

Don't soak the syringe directly in solution. Don't use an ultrasonic cleaner.

In case of irregular water output, clean nozzle using the proper wire provided.

Only the outside cover of the syringe (nozzle and handle together (2.1 - pict. 2) may be removed, just pulling it away from the inside body (2.2 - pict. 2), which remains connected to the hose) and **sterilized in water steam autoclave or chemiclave up to 135 °C, 210 kPa (2.1 bar) for 20 min.**

In order to maintain a proper level of hygienic safety autoclave after the use on each patient.

Don't remove the nozzle from the handle for sterilisation purpose.

Remove the outside cover of the syringe from autoclave immediately after the cycle.

Warning! Pay attention not to press A and B controls (Pict. 1) when removing and fitting again the outside cover.

When fitting the outside cover rotate slowly into the position that allows a complete fitting until it clicks.

Warning! Check the autoclave periodically according to the manufacturer's prescriptions! Temperature exceeding the above stated limit may damage the handpiece!

- Before carrying out the "TIME FLUSHING" disinfection cycle, you must place the plastic ring (4.1) on the body of the syringe and above the water control (as shown in Pict. 4) to allow flow of the liquid for disinfecting the handpieces.
- Whenever you note an appreciable decrease in the flow of water to the syringe, **and in any case at least once every six months, you must replace the filter (50µ)** (part 15B.2 - pict. 5) situated in the lower part of the instrument tray

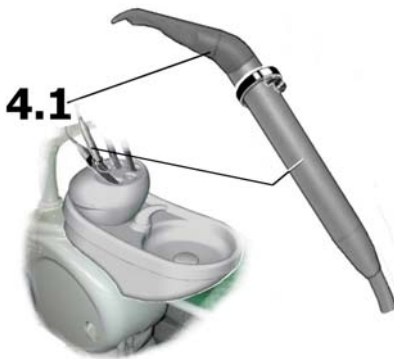

Pict. 4 – Disinfecting

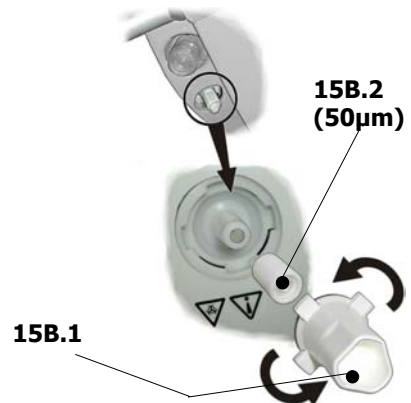

Pict. 5 – Water filter

(see **"Part I – Instructions for Use and Maintenance – Routine Maintenance**). If a supplementary "Threesteril" syringe is present in the assistant's tray, whenever you note an appreciable decrease in the flow of water to the syringe **you must replace the filter** (part 5.1 – pict. 6) installed inside the dental unit body (see "Part IV – Instructions for Installation – Removal of Protective Coverings); **this filter must in any case be replaced at least once a year.**

TROUBLESHOOTING

- In the event of a **poor delivery of air and/or water, do not try to adjust** the pressure controls on the unit. It is possible to clean the water duct on the nozzle by means of the supplied steel wire. If a result is not achieved, ask for Technical Assistance.
- In the event of water **continuous leakage**, turn the main switch of the unit off and ask for Technical Assistance.

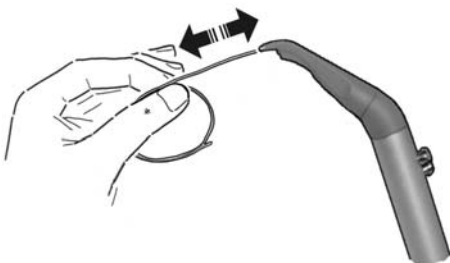

Pict. 3 – Cleaning of the tip

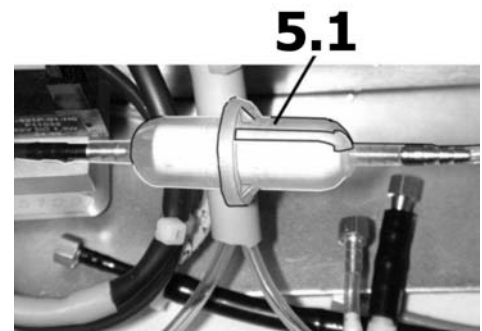

Pict. 6 – Water filter (only for additional syringe)

"MULTISTERIL 2 TITANIUM" SYRINGE

GENERAL SPECIFICATION

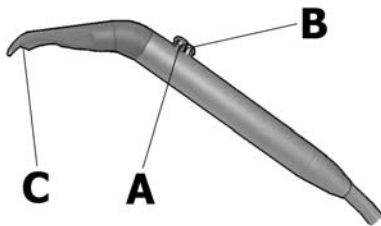

Pict. 1 – Overall view

The "Multisteril 2 Titanium" syringe is available in three models: cold, warm and warm with an integrated device for lighting the operating area. It allows supply of either water, air or spray (i.e. water and air simultaneously) by pressing control **A (water)**, **B (air)** or **A and B together (spray effect)**. See pict. 1.

Air supply may be adjusted according to the pressure applied on control B.

The nozzle may be rotated. It holds the bulb and the fiber optics (**C** - pict. 1) for lighting the operating field when requested,

The warm syringe has to be subjected to **intermittent operation** as follows: 10 s work, 5 min stand-by.

Warning! Before using the syringe be sure that nozzle and outside cover are correctly fitted on the syringe body.
Don't use the syringe if it is visibly damaged. Contact an authorized technical service centre.

CONNECTION TO THE UNIT

The "Multisteril 2 Titanium" syringe needs specific supply circuits for air, water and power: therefore it can be fitted only on specifically arranged dental units. Its eventual connection to not originally arranged units must be carried out by skilled personnel, authorised by Castellini S.p.A.

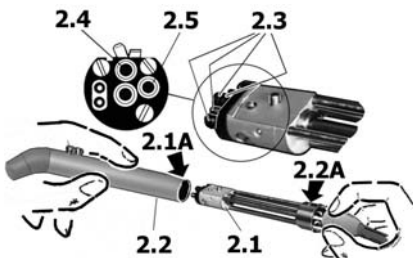

Pict. 2 – Connection to the unit

The dental equipment has been set by Castellini S.p.A. to supply water and air with correct pressure for the syringe:

air pressure: min 330 kPa (3.3 bar) max 460 kPa (4,6 bar)
measured in position 2.5 - pict. 2;

water pressure: min 90 kPa (0.9 bar) max 140 kPa (1.4 bar)
measured in position 2.4 - pict. 2

Do not exceed in any case these pressure ranges.

After having fitted the syringe on its hose, tighten ring (**3.1** - pict. 3).

INTEGRATED LIGHTING DEVICE

The bulb will light on as soon as the syringe is lifted from the dental unit table; at the same time a jet of air will flow to remove the generated heat. Light will remain on till the syringe is placed on the unit table again.

The bulb must be supplied with max 3.5 Vdc.

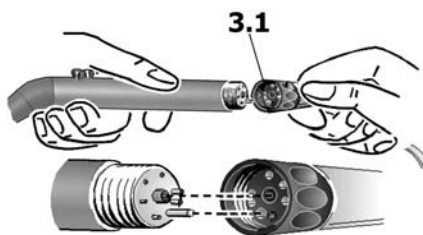

Pict. 3 – Attachment to the unit

REPLACING THE BULB (Pict. 4)

Remove the nozzle (**5.1**) from the syringe outer body just pulling it off and, by means of a pointed device, remove the bulb (**5.2**).

Fit the new bulb into position coupling the two contacts with the socket contacts: the bulb fits properly only in this position.

Don't touch the bulb with bare hands. If this occurs, clean it with cotton and alcohol. **N.B.: The bulb life is approximately 50 hours**

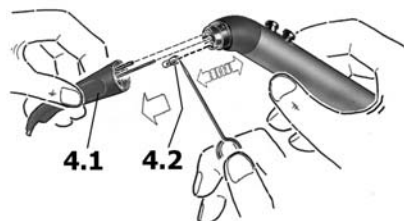

Pict. 4 – Replacing the bulb

USING SAFELY: rules and recommendations

To ensure that the equipment is used safely, the user must abide by the set standards of hygiene and professional diligence. The following points should also be kept in mind:

- During use, dust and fragments of material from the patient's mouth or the device being used may be thrust into the surrounding environment (organic and inorganic particles, metal dust, liquids, potentially infected fluids and biological materials):

PERSONNEL MUST DULY PROTECT THEIR EYES, BREATHING PASSAGES, MOUTH AND SKIN by wearing safety

glasses, face shields, masks and disposable gloves. Operate the suction system at high speed in all operations likely to result in a discharge of materials, dust and aerosols to minimise their dissemination. N.B.: it is not advisable to use drinking water to supply the dental unit, since it may lead to the formation of a biofilm in the waterlines and thus facilitate germ proliferation inside the unit itself; It is recommended to supply the unit exclusively with dedicated liquids (Isotonic Saline Solution or I.P.Purified Water) using the Separate Supply system.

SERVICING

It is indispensable to supply the syringe with air and water conveniently filtered. Regular maintenance of the filters in the unit and draining the condensate from the compressor tank is therefore recommended.

Grease O-rings (2.3 - pict. 2) with silicon lubricant S1 once a week. Wearing protective disposable gloves, apply a small amount of S1 on fingers and lubricate by it.

CLEANING, DISINFECTING, STERILIZING

ATTENTION: The instrument is supplied not sterile.

Before use sterilize according to the following specifications.

Use gauze or cotton soaked in ethyl alcohol at 70% to clean and disinfect syringe exterior.

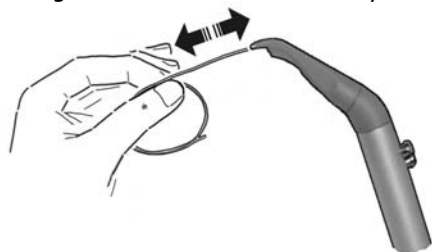

Pict. 5 – – Surgical application tip

Don't soak the syringe directly in solution. Don't use an ultrasonic cleaner. Clean fibre-optics terminal with alcohol-soaked cotton.

In case of irregular water output, clean nozzle using the proper wire provided.

Only the outside cover of the syringe (nozzle and handle together (2.1 - pict. 2) may be removed, just pulling it away from the inside body (2.2 - pict. 2), which remains connected to the hose) and sterilized in water steam autoclave up to 135 °C - 210 kPa (2.1 bar) for 20 min.

In order to maintain a proper level of hygienic safety autoclave after the use on each patient.

Don't remove the nozzle from the handle for sterilisation purpose.

Remove the outside cover of the syringe from autoclave immediately after the cycle.

Warning! Pay attention not to press A and B controls (Pict. 1) when removing and fitting again the outside cover.

When fitting the outside cover make sure that inner slot (2.1A) is in line with screw (2.2A - Pict. 2). The outside cover must be inserted all the way.

Important! The nozzle (4.1 - Pict. 4) must be removed from the syringe body only when replacing the bulb.

Warning! Check the autoclave periodically according to the manufacturer's prescriptions!

Temperature exceeding the above stated limit may damage the handpiece!



6.1

The traditional tip (4.1 – pict.. 4) may be replaced, (*subject to request*) with the surgical application tip (6.1 – pict.. 6) by simply pulling it off the handle

TROUBLESHOOTING

- In the event of a **poor delivery of air and/or water**, do not try to adjust the pressure controls on the unit. It is possible to clean the water duct on the nozzle by means of the supplied steel wire (Pict. 5). If a result is not achieved, ask for Technical Assistance.

- In the event of water continuous **leakage from the syringe nozzle**, turn the main switch of the unit off and ask for Technical Assistance.
- In the event of **water leakage from the connection to the hose**, check that coupling ring (3.1 - Pict. 3) is correctly tightened.
- In the event of **heating device failure**, ask for Technical Assistance.

Warning! The syringe nozzle may reach **excessive temperature** if the cooling air is not supplied simultaneously when lighting the bulb on because of a device failure on the unit. In this event, turn the light off by means of the control on the unit and ask for Technical Assistance.

"CLEANAIR 2000" - "CLEANLIGHT 2000" TURBINE

GENERAL SPECIFICATIONS

| | Testina Standard | Testina miniature |
|----------------------------------|-------------------------------|-------------------------------|
| Speed | 340.000 ÷ 366.000 giri/min | 380.000 ÷ 420.000 giri/min |
| Air working pressure (handpiece) | 240÷260 kPa (2.4÷2.6 bar) | 260÷280 kPa (2.6÷2.8 bar) |
| Water pressure | 37 ÷ 40 lt/min | 30 ÷ 33 lt/min |
| Air delivery | 70÷140 kPa 0.7÷1.4 bar) | 70÷140 kPa (0.7÷1.4 bar) |
| Burr stem diameter | 1.590 ÷ 1.600 mm (ISO 1797-1) | 1.590 ÷ 1.600 mm (ISO 1797-1) |
| Max burr length | 26 mm | 19 mm |
| Min burr lock length | 11.7 mm | 11.2 mm |
| Max burr diameter | 2 mm | 2 mm |
| Classification: | IIa (93/42 EEC Directive) | |

Note: The rotation velocity measurement unit SI is "rad/sec".

$$1 \text{ rad/sec} = \frac{\pi}{30} \text{ RPM}$$



WARNING!

- High speed handpiece!
- An excessive pressure may damage the tooth!
- Cool the operating area conveniently!
- Stop the turbine immediately if the cooling media don't flow!
- Do not use burs with dimensions exceeding the above mentioned limits!
- Do not use worn or damaged burs! Handle burs with care wearing protective gloves!
- Castellini does not supply the burs for the turbines and handpieces and PRESCRIBES the use of only burs (or other similar tools) that bear the EC mark of conformity with EEC Directive 93/42.
- Before every use, check that the burr is correctly locked in the gripper (see section "BURR LOCKING").
- The burr release button becomes very hot if it is pushed while the turbine is running. Pay the greatest attention not to push it unintentionally against the Patient's oral cavity.
- Do not use the instrument if it is visibly damaged or if unusual noises and/or vibrations are produced. Contact an authorised technical service centre.
- For the use of this instrument the rubber dam must be applied on the patient.

The high speed air turbine has to be subjected to intermittent operation: 20 min work, 10 min stand-by.

USING SAFELY: rules and recommendations

To ensure that the equipment is used safely, the user must abide by the set standards of hygiene and professional diligence.

The following points should also be kept in mind:

- During use, dust and fragments of material from the patient's mouth or the device being used may be thrust into the surrounding environment (organic and inorganic particles, metal dust, liquids, potentially infected fluids and biological materials):

PERSONNEL MUST DULY PROTECT THEIR EYES, BREATHING PASSAGES, MOUTH AND SKIN by wearing safety glasses, face shields, masks and disposable gloves. Operate the suction system at high speed in all operations likely to result in a discharge of materials, dust and aerosols to minimise their dissemination.

N.B.: it is not advisable to use drinking water to supply the dental unit, since it may lead to the formation of a biofilm in the waterlines and thus facilitate germ proliferation inside the unit itself; **It is recommended to supply the unit exclusively with dedicated liquids** (Isotonic Saline Solution or I.P.Purified Water) using the Separate Supply system.

HANDPIECE CONNECTIONS

Handpieces without fiber optics

-handpiece with four ways coupling - ISO 9168

Handpieces with fiber optics

-handpiece with four ways plus two electric contacts coupling



Pict. 2 – Driving Air Pressure

REGULATING DRIVING AIR PRESSURE (Pict. 2)

Connect the fitting with the pressure gauge between the tubing and handpiece or between the tubing and faston. Operate the high-speed handpiece and check pressure. The standard-head and miniature-head handpieces can be interchanged without adjusting pressure.

Driving air pressure range:

Screw-coupling handpieces: 240÷250 kPa (2.4÷2.5 bar) per testina standard
260÷280 kPa (2.6÷2.8 bar) per testina miniature

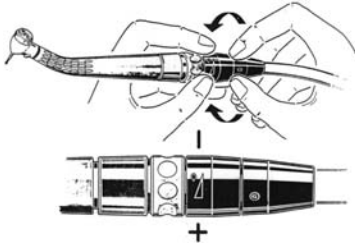

Pict 3 – Regulating spray water

REGULATING SPRAY WATER (Pict. 3)

Use the ring on the tubing coupling to control water supply.

BURR LOCKING SYSTEMS

Burr locking: screw-type with key (Pict. 4)

Fit key (2) into head, introduce bur (3) and turn knob clockwise, tightening gently -. The key can be sterilized in autoclave.

Burr locking: push-button type (Pict. 5)

Simply press down with thumb in the centre of handpiece head back cover to remove and introduce a new bur, and lift thumb to lock in place.

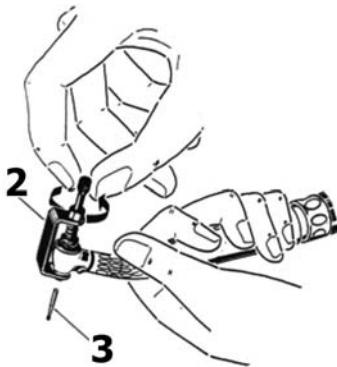

Pict. 4 – Burr locking: screw-type with key

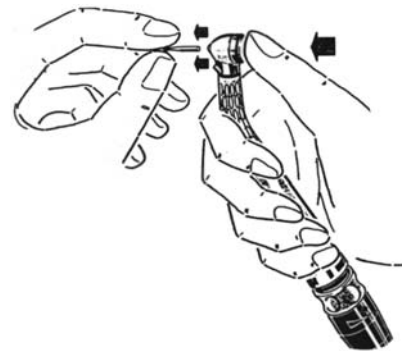

Pict. 5 – Burr locking: push-button type"



Check the correct fitting of the bur pulling it by hand.

Push bur all the way in for correct fitting. Always use burs with 1.590 - 1.600 mm standard stem (ISO 1797-1).

To prevent damage, NEVER release bur until high-speed handpiece stops turning.

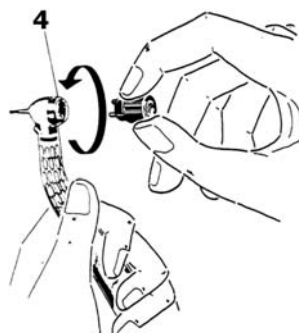

Pict. 6 – Replacing high speed handpiece rotor

REPLACING HIGH SPEED HANDPIECE ROTOR (Picts. 6 - 7)

The rotor is field replaceable. Unscrew cap of head (4) with the key (pict.5). Before fitting a new rotor, make sure that O-Rings (5) are in their correct position, i.e. in the head and cap. Now screw on cap tightly.

When replacing the rotor replace also the O-Rings and the wavy washer in the cap (Pict. 7).

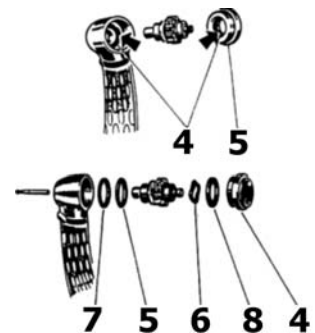

Pict. 7 – replace also the O-Rings

LIGHTING DEVICE

The halogen microlamp on the faston coupling has to be powered with a **maximum 3.5 VDC** source. NEVER touch it with bare hands. If this occurs, clean lamp with cotton wool and alcohol.

The lamp lights automatically when the high-speed handpiece is working; when it stops, the light will stay on for a set time (up to 20 s maximum).

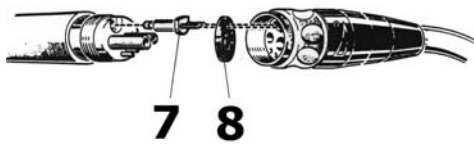

Pict. 8 - Replacing lamp screw-coupling handpieces

REPLACING LAMP

Screw-coupling handpieces (Pict. 8)

Detach handpiece from tubing, slide off seal (8) and remove lamp (7). Put in new lamp, replace seal (8) (make sure holes are properly positioned) and reconnect handpiece to tubing.

N.B.: The bulb life is approximately 50 hours

LUBRICATING HIGH SPEED HANDPIECE

Use the spray-can "DAILY OIL" to lubricate at least once daily and in the hereafter indicated circumstances the high-speed handpiece. Follow the instructions on can, remembering to apply lubricant in two short sprays. Eliminate any excess lubricant before use by operating the handpiece (hold it over cuspidor) and wiping in with gauze and cotton.



Pict. 10 – Handpiece lubrication

Do this with bur in place to prevent mechanical damage to handpiece.

In addition it is imperative to lubricate as follows:

- Before and after autoclaving
- Before and after every AUTOSTERIL disinfecting or sterilizing cycle.

Regular use of this spray lubricant assures best working order.

Proceed as shown in Pict. 10 for screw coupling

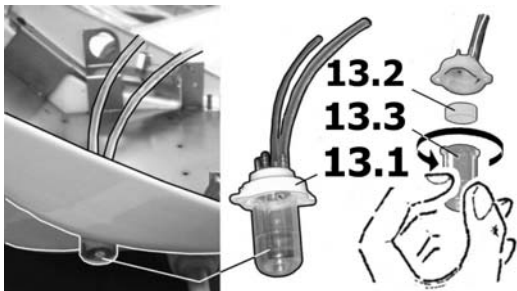

Pict. 13 – Condensation filter disassemble

Should you observe a significant increase in the build up of condensation inside the filter (13.1 – Pict. 9) situated beneath the dental unit instrument tray, remove the cover (13.2) by turning it clockwise about a ¼ of a turn, replace the filtering element (13.3) and eliminate the liquids present

the filtering element must be replaced for the first time within a year of the date shown on the cover and at least once a year thereafter

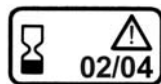

WARNING DANGER OF BACTERIAL CONTAMINATION!

The liquid condensate inside the cover must be handled and disposed of by personnel wearing disposable gloves and eye protection and always in compliance with Sanitary Regulations for the disposal of Waste associated with a High Biological Hazard.

Before replacing the cover, thoroughly wash and disinfect it. Do not use products containing denatured alcohol, since the material is not alcohol resistant.

CLEANING, DISINFECTING, STERILIZING

ATTENTION: The instrument is supplied not sterile.

Before use sterilize according to the following specifications.

Wear protective gloves! Remove the burr!

Use gauze or cotton soaked in ethyl alcohol at 70% to clean and/or disinfect handpiece exterior. **DO NOT soak handpiece directly in solution.** DO NOT use an ultrasonic cleaner.

Clean the spray nozzle after each operation: use the steel wire supplied and the syringe to blow on the nozzle. Clean fibre-optic terminals with alcohol-soaked gauze.

In order to maintain a proper level of hygienic safety handpieces must be sterilized in autoclave with water steam up to 135°C, 210 kPa (2.1 bar) for 20 min, after the use on each patient. Never sterilize handpieces in dry-heat sterilizers.

Before and after each autoclaving, lubricate handpiece and clean fibre-optic terminals. Never leave handpieces in autoclave overnight: always remove them from autoclave after each cycle.

Before and after each autoclaving, lubricate handpiece and clean fibre-optic terminals. Never leave handpieces in autoclave overnight: always remove them from autoclave after each cycle.

**Warning! Check the autoclave periodically according to the manufacturer's prescriptions!
Temperature exceeding the above stated limit may damage the handpiece!**



IMPORTANT

WE PRESCRIBE TO STOP WORKING IMMEDIATELY IN THE EVENT OF UNUSUAL NOISE, STRONG VIBRATION OR IF BUR IS NOT KEPT FIRMLY IN POSITION.

TROUBLESHOOTING

| PROBLEM | LIKELY CAUSE | REMEDY |
|--|---------------------------------|---|
| Low power on high speed handpiece; abrupt rpm loss | Irregular air pressure | Check and adjust |
| | Air leaks at tubing coupling | Tighten coupling ring or replace O-Rings if worn |
| | Blocked air way | Check tubing or replace it |
| | Handpiece needs lubrication | Lubricate repeatedly between brief runs |
| | Worn out bearings | Replace rotor assembly |
| Very noisy handpiece | Misaligned or very worn bur | Fit in new bur |
| | Worn out bearings | Replace rotor assembly |
| Defective attaching or detaching bur: key-type bur clamp | Square section of shaft rounded | Replace rotor assembly |
| | Worn key | Order new key |
| | Worn clamp | Replace clamp |
| | Not-calibrated bur diameter | Use only quality burs |
| | Curved bur | Use new bur |
| Defective attaching or detaching bur: push-button clamp | Not-calibrated bur diameter | Use only quality burs |
| | Curved bur | Use new bur |
| | Worn clamp | Replace rotor assembly |
| | Button not fully pressed down | Push the button at centre all the way |
| Defective spray | | Detach handpiece, hold tube over cuspidor and blow out air and water. N.B. Water regulator must be open |
| | Blocked nozzles | Clean handpiece: use supplied steel wire carefully so as not to ovalize nozzles. |
| No light in fibre-optic handpiece | Burned out lamp | Replace lamp |
| | Defective tube coupling | Tighten fully the handpiece tube coupling ring, or, if not enough, replace tube assembly |
| Water leaks from coupling | Loose tubing | Tighten fully coupling ring |

"HI-POWER 2 CERAMIC" – "TITANIUM GOLD 2" - "TITANIUM GOLD 2 MINIATURE" TURBINE

GENERAL TECHNICAL DATA

| | Hi-Power 2 Ceramic/ Titanium Gold 2 | Titanium Gold 2 Miniature |
|----------------------------------|--|----------------------------------|
| Speed | 350.000 ÷ 366.000 rpm | 380.000 ÷ 400.000 rpm |
| Air working pressure (handpiece) | 260 ÷ 280 kPa (2.6 ÷ 2.8 bar) | 280 ÷ 300 kPa (2.8 ÷ 3 bar) |
| Air delivery | 48 ÷ 51 lt/min | 44 ÷ 47 lt/min |
| Water pressure | 70÷140 kPa (0.7÷1.4 bar) | 70÷140 kPa (0.7÷1.4 bar) |
| Burr stem diameter | 1.590 ÷ 1.600 mm (ISO 1797-1) | 1.590 ÷ 1.600 mm (ISO 1797-1) |
| Max burr length | 26 mm | 19 mm |
| Min burr lock length | 11.7 | 11.2 |
| Max burr diameter | 2 mm | 2 mm |
| Classification: | IIa (93/42 EEC Directive) | |

Note: The rotation velocity measurement unit SI is "rad/sec". $1 \text{ rad/sec} = \frac{\pi}{30} \text{ RPM}$



Warning!:

- **High speed handpiece!**
- **An excessive pressure may damage the tooth!**
- **Cool the operating area conveniently!**
- **Stop the turbine immediately if the cooling media don't flow!**
- **Do not use burrs with dimensions exceeding the above mentioned limits!**
- **Do not use worn or damaged burrs! Handle burrs with care wearing protective gloves!**
- **Castellini does not supply the burrs for the turbines and handpieces and PRESCRIBES the use of only burrs (or other similar tools) that bear the EC mark of conformity with EEC Directive 93/42.**
- **Before every use, check that the burr is correctly locked in the gripper (see section "BURR LOCKING").**
- **The burr release button becomes very hot if it is pushed while the turbine is running. Pay the greatest attention not to push it unintentionally against the Patient's oral cavity.**
- **Do not use the instrument if it is visibly damaged or if unusual noises and/or vibrations are produced. Contact an authorised technical service centre.**
- **For the use of this instrument the rubber dam must be applied on the patient.**

The high speed air turbine has to be subjected to intermittent operation: 20 min work, 10 min stand-by.

USING SAFELY: rules and recommendations

To ensure that the equipment is used safely, the user must abide by the set standards of hygiene and professional diligence.

The following points should also be kept in mind:

- During use, dust and fragments of material from the patient's mouth or the device being used may be thrust into the surrounding environment (organic and inorganic particles, metal dust, liquids, potentially infected fluids and biological materials):

PERSONNEL MUST DULY PROTECT THEIR EYES, BREATHING PASSAGES, MOUTH AND SKIN by wearing safety glasses, face shields, masks and disposable gloves.

Operate the suction system at high speed in all operations likely to result in a discharge of materials, dust and aerosols to minimise their dissemination.

N.B.: it is not advisable to use drinking water to supply the dental unit, since it may lead to the formation of a biofilm in the waterlines and thus facilitate germ proliferation inside the unit itself; **It is recommended to supply the unit exclusively with dedicated liquids** (Isotonic Saline Solution or I.P.Purified Water) using the Separate Supply system.

HANDPIECE CONNECTION

The handpiece must be connected to its hose by means of Castellini faston coupling which has four ways plus two electric contacts coupling section.



Pict. 1 – Assembly/disassembly Castellini-faston handpiece

CASTELLINI-FASTON HANDPIECE: ASSEMBLY AND DISASSEMBLY (Pict. 1)

Screw in the faston tightly to the flexible handpiece tubing.
 Lubricate O-Rings with specific S1 lubricant. Fit the handpiece over the faston coupler check that it is firmly connected pulling it by hand while rotating it.
 To remove the handpiece, pull back and slide off by turning it gently. *Don't remove the handpiece while the burr is rotating!*



Pict. 2 - Regulating driving air pressure

REGULATING DRIVING AIR PRESSURE (Pict. 2)

Connect the fitting with the pressure gauge between the tubing and faston. Operate the high-speed handpiece and check pressure (Pict. 2).

Driving air-pressure:

260 ÷ 280 kPa (2.6 ÷ 2.8 bar) for Hi-Power 2 Ceramic e Titanium Gold 2.

280 ÷ 300 kPa (2,8÷3 bar) for Titanium Gold 2 Miniature.

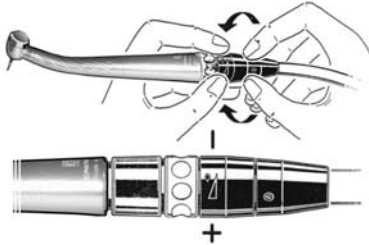

Pict. 3 - Regulating spray water

REGULATING SPRAY WATER (Pict. 3)

Use the ring on the tubing coupling to control water supply.

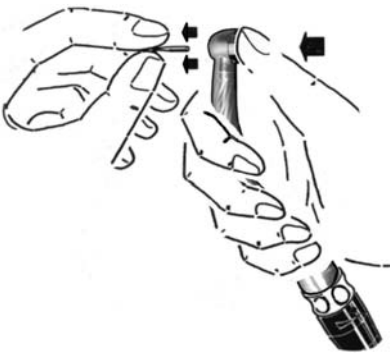

Pict. 4 - Burr locking

BURR LOCKING

Burr locking: push-button type (Pict. 4)

Simply press down with thumb in the centre of handpiece head back cover to remove and introduce a new burr, and lift thumb to lock in place.



Check the correct fitting of the burr pulling it by hand. Wear protective gloves!

Push burr all the way in for correct fitting. Always use burs with 1.590-1.600 mm standard stem (ISO 1797-1).

To prevent damage, NEVER release burr until high-speed handpiece stops turning.

REPLACING HIGH SPEED HANDPIECE ROTOR (Picts. 5 - 6)

The rotor is field replaceable. Unscrew cap of head (4) with the key (pict.5). Before fitting a new rotor, make sure that O-Rings (5) are in their correct position, i.e. in the head and cap. Now screw on cap tightly.

When replacing the rotor replace also the O-Rings and the wavy washer in the cap (Pict. 6).

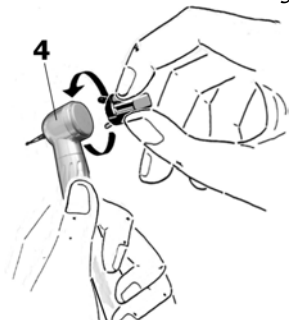

Pict. 5 - Replacing high speed handpiece rotor

LIGHTING DEVICE

The halogen microlamp on the faston coupling has to be powered with a **maximum 3.5 VDC** source. NEVER touch it with bare hands. If this occurs, clean lamp with cotton wool and alcohol.

The lamp lights automatically when the high-speed handpiece is working: when it stops, the light will stay on for a set time (up to 20 s maximum).

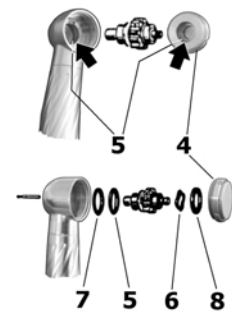

Pict. 6 - replace also the O-Rings

REPLACING LAMP (Pict. 7)

Disconnect the handpiece from faston coupling. Unscrew the front part (9) of the faston coupling and remove bulb. Put a new bulb in place and screw (9) again.

N.B.: The bulb life is approximately 50 hours

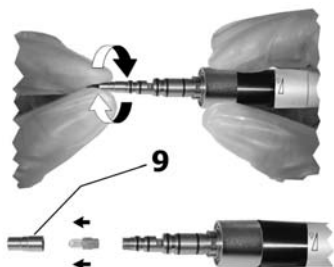

Pict. 7 - Replacing lamp

LUBRICATING HIGH SPEED HANDPIECE (Pict. 8)

Use the spray-can "DAILY OIL" to lubricate at least once daily and in the hereafter indicated circumstances the high-speed handpiece.

Follow the instructions on can, remembering to apply lubricant in two short sprays.



Pict. 8 – Handpiece lubrication

Eliminate any excess lubricant before use by operating the handpiece (hold it over cuspidor) and wiping in with gauze and cotton. Do this with burr in place to prevent mechanical damage to handpiece.

In addition it is imperative to lubricate as follows:

- Before and after autoclaving
- Before and after every AUTOSTERIL disinfecting or sterilizing cycle.

Regular use of this spray lubricant assures best working order. Proceed as shown in Pict. 8.

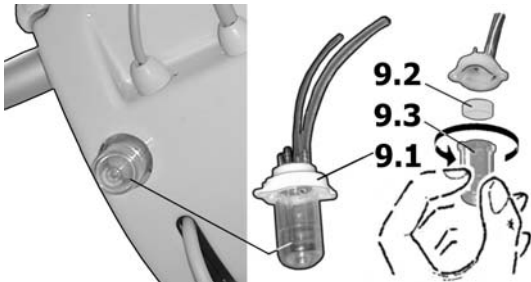

Pict. 9 - Condensation filter disassemble

Should you observe a significant increase in the build up of condensation inside the filter (9.1 – Pict. 9) situated beneath the dental unit instrument tray, remove the cover (9.2) by turning it clockwise about a ¼ of a turn, replace the filtering element (9.3) and eliminate the liquids present; **the filtering element must be replaced for the first time within a year of the date shown on the cover and at least once a year thereafter.**



WARNING DANGER OF BACTERIAL CONTAMINATION!

The liquid condensate inside the cover must be handled and disposed of by personnel wearing disposable gloves and eye protection and always in compliance with Sanitary Regulations for the disposal of Waste associated with a High Biological Hazard.

Before replacing the cover, thoroughly wash and disinfect it. Do not use products containing denatured alcohol, since the material is not alcohol resistant.

CLEANING, DISINFECTING, STERILIZING

ATTENTION: The instrument is supplied not sterile.

Before use sterilize according to the following specifications.

Wear protective gloves! Remove the burr!

Use gauze or cotton soaked in ethyl alcohol at 70% to clean and/or disinfect handpiece exterior. **DO NOT soak handpiece directly in solution.** DO NOT use an ultrasonic cleaner.

Clean the spray nozzle after each operation: use the steel wire supplied and the syringe to blow on the nozzle. Clean fibre-optic terminals with alcohol-soaked gauze.

In order to maintain a proper level of hygienic safety handpieces must be sterilized in autoclave with water steam up to 135°C, 210 kPa (2.1 bar) for 20 min, after the use on each patient. Never sterilize handpieces in dry-heat sterilizers.

Before and after each autoclaving, lubricate handpiece and clean fibre-optic terminals. Never leave handpieces in autoclave overnight: always remove them from autoclave after each cycle.

Warning! Check the autoclave periodically according to the manufacturer’s prescriptions! Temperature exceeding the above stated limit may damage the handpiece!

SERVICING THE CASTELLINI FASTON CONNECTION

Lubricate at least weekly the O-Rings with silicone lubricant S1, distributed by Castellini S.p.A. Wearing protective disposable gloves, apply a small amount of S1 on fingers and use it for lubricating.

If faston coupling leaks, replace the O-Rings: grasp them with two fingers and slide them along one side and forward to remove them. Slip on the new rings, fit them properly into the grooves and lubricate.

Important! The faston coupling **CANNOT** be sterilized in autoclave.

IMPORTANT

WE PRESCRIBE TO:

STOP WORKING IMMEDIATELY IN THE EVENT OF UNUSUAL NOISE, STRONG VIBRATION OR IF BUR IS NOT KEPT FIRMLY IN POSITION.



TROUBLESHOOTING

| PROBLEM | LIKELY CAUSE | REMEDY |
|--|---------------------------------|---|
| Low power on high speed handpiece; abrupt rpm loss | Irregular air pressure | Check and adjust |
| | Air leaks at tubing coupling | Tighten coupling ring or replace O-Rings if worn |
| | Blocked air way | Check tubing or replace it |
| | Handpiece needs lubrication | Lubricate repeatedly between brief runs |
| | Worn out bearings | Replace rotor assembly |
| Very noisy handpiece | Misaligned or very worn bur | Fit in new bur |
| | Worn out bearings | Replace rotor assembly |
| Defective attaching or detaching bur: key-type bur clamp | Square section of shaft rounded | Replace rotor assembly |
| | Worn key | Order new key |
| | Worn clamp | Replace clamp |
| | Not-calibrated bur diameter | Use only quality burs |
| | Curved bur | Use new bur |
| Defective attaching or detaching bur: push-button clamp | Not-calibrated bur diameter | Use only quality burs |
| | Curved bur | Use new bur |
| | Worn clamp | Replace rotor assembly |
| | Button not fully pressed down | Push the button at centre all the way |
| Defective spray | | Detach handpiece, hold tube over cuspidor and blow out air and water. N.B. Water regulator must be open |
| | Blocked nozzles | Clean handpiece: use supplied steel wire carefully so as not to ovalize nozzles. |
| No light in fibre-optic handpiece | Burned out lamp | Replace lamp |
| | Defective tube coupling | Tighten fully the handpiece tube coupling ring, or, if not enough, replace tube assembly |
| Water leaks from coupling | Loose tubing | Tighten fully coupling ring |
| | Worn faston O-Rings | Replace and lubricate them. |

"IMPLANTOR 2" and " IMPLANTOR 2L" MICROMOTOR



(only if request)

GENERAL TECHNICAL DATA

| | |
|--------------------------|---|
| Input | 32 VDC max |
| Max Speed | 50.000±10% rpm |
| Min Speed | 200 ±10% rpm |
| Max torque | 4 Ncm |
| Cooling | Forced air |
| Intermittent operation | 5 min work - 25 min stand-by |
| Air supply | 420 ± 20 kPa (4,2 ± 0,2 bar) at the exit of the syringe |
| Water supply | 120 ± 20kPa (1,2 ± 0,2 bar) at the exit of the syringe |
| Air cooling consumption | ~ 33 NI/min |
| Spray air consumption: | ~ 5 NI/min |
| Spray water consumption: | 35 cc/min |
| Classification: | IIa (93/42 EEC Directive) |

Note: The rotation velocity measurement unit SI is "rad/sec". $1 \text{ rad/sec} = \frac{\pi}{30} \text{ RPM}$

WARNING!

- Before every use, check that the handpiece is firmly secured to the micromotor and that the burr is correctly locked in the handpiece gripper.
- Cool the operating area conveniently!
- Only handpieces and burs (or other similar tools) EC-marked according to Directive 93/42 EEC must be used.
- Do not use the instrument if it is visibly damaged or if unusual noises and/or vibrations are produced. Contact an authorised technical service centre.
- For the use of this instrument the rubber dam must be applied on the patient.
- A cooling air stream through the hose is indispensable during the motor running.
- Do not change the technical parametrer of the functioning.

USING SAFELY: rules and recommendations

To ensure that the equipment is used safely, the user must abide by the set standards of hygiene and professional diligence. The following points should also be kept in mind:

- During use, dust and fragments of material from the patient's mouth or the device being used may be thrust into the surrounding environment (organic and inorganic particles, metal dust, liquids, potentially infected fluids and biological materials):

PERSONNEL MUST DULY PROTECT THEIR EYES, BREATHING PASSAGES, MOUTH AND SKIN by wearing safety glasses, face shields, masks and disposable gloves.

Operate the suction system at high speed in all operations likely to result in a discharge of materials, dust and aerosols to minimise their dissemination. **N.B.: it is not advisable to use drinking water to supply the dental unit**, since it may lead to the formation of a biofilm in the waterlines and thus facilitate germ proliferation inside the unit itself; **It is recommended to supply the unit exclusively with dedicated liquids** (Isotonic Saline Solution or I.P.Purified Water) using the Separate Supply system.

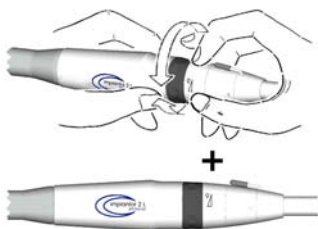

Pict. 1 – Water spray regulation

REGULATION

The input for the micromotor must be provided by the special Castellini stabilized power supply box - inside the unit - and the relative cable and wiring. To control speed or change direction of rotation, adjust the controls on the unit.

The amount of water for the spray is easily regulated by opening or closing the control on the pipe connection, as shown in pict. 1.

To cut off the spray, adjust the controls on the unit.

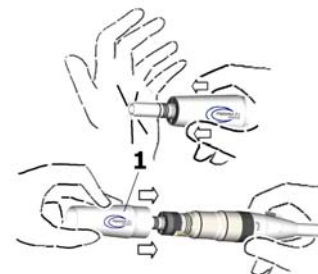

Pict. 3 – Carter disassemble

CONNECTION TO THE SUPPLY HOSE

It is advisable to take off the outside cover as shown in pict. 3. Place the motor near the hose mating the two spray tubes (the long ones) with the two steel sockets on the hose connection (pict. 4). Push the motor against the hose and screw tight the locking ring. Place cover (1) again on to the motor and push until it clicks.



Pict. 2 – Connection to the supply hose

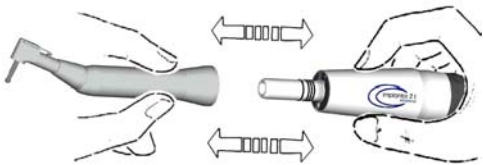

Pict. 4 - Connecting and disconnecting handpieces

CONNECTING AND DISCONNECTING HANDPIECES (Pict. 4)

Handpieces complying with ISO 3964 or INTRAmatic ® Lux type may be fitted.

Fit the handpiece over the connection stem and push until it clicks. Be sure the handpiece can swivel freely. Damaged or worn handpieces are not be used.

For disconnecting a handpiece simply pull it out, as shown on pict. 2.

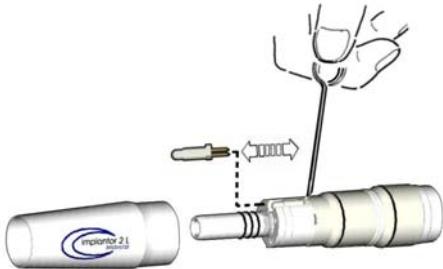

Pict. 5 - Replacing bulb

LIGHTING DEVICE

The lighting device must be supplied with max 3.5 VDC. The handpiece lights up automatically when the micromotor is running: when it stops, the light will stay on for a set time (variable to a 20 s maximum).

REPLACING BULB (Pict. 5)

Take off the outside cover and pull out the lamp with a little screwdriver or another tool. Connect the lamp as to the bottom of its seat.

N.B.: The bulb life is approximately 50 hours

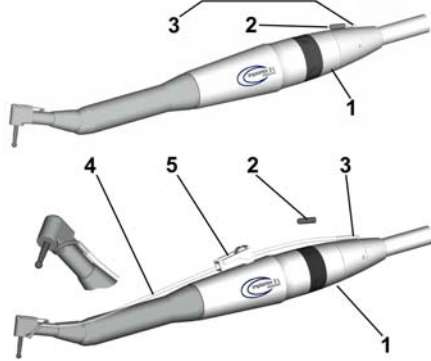

Pict. 6 - Replacing bulb

USING THE LOW-SPEED MOTOR WITH EXTERNAL COOLING FLUID (Pict. 6)

- 1) Move the ring nut (1) into the closed position;
- 2) remove the cap (2) from the connector (3) and connect one end of the tube (4) in its place;
- 3) connect the other end of the tube (4) to the external connector on the handpiece;
- 4) adjust flow by means of the regulator (5).

To switch back to the internal cooling fluid conpict.uration, disconnect the tube (4) and replace the cap (2) on the connector (3). Adjust flow with the ring nut (1).

To replace the tube (4), hold the wheel of the regulator (5) in the completely open position. Then remove the tube and replace it with a new one.

The tube (4) and regulator (5) may be sterilised in a steam autoclave at 135 °C, 210 kPa (2,1 bar) for 20 minutes. They should be autoclaved after use on each patient.

N.B.: After use of a potentially encrusting solution, we prescribe to wash the hydraulic circuit with a water flow

SERVICING

NEVER LUBRICATE THE ELECTRICAL MICROMOTOR! Pay attention that the lubrication oil for handpieces doesn't drip into the motor body.

At least once a week remove the outside cover and lubricate the two O-rings on the micromotor body and the three spray seal rings on the handpiece connection stem (pict. 2): use the specific grease S1 distributed by CASTELLINI S.p.A. Wearing protective disposable gloves, apply a small amount of S1 on fingers and lubricate by it.

Any other technical assistance to the motor must be carried out by specialized personnel, authorized by CASTELLINI S.p.A.

CLEANING, DISINFECTING, STERILIZING

ATTENTION: The instrument is supplied not sterile.

Before use sterilize according to the following specifications.

The outside cover of the motor may be cleaned and disinfected by means of cotton soaked in ethyl alcohol at 70%. Also, it may be taken off as shown in pict. 3 and sterilized in a steam autoclave up to 135 °C, 210 kPa (2.1 bar) for 20 min. **In order to maintain a proper level of hygienic safety, autoclave after the use on each patient. Clean and desinfect prior to sterilizing.**

**IMPORTANT: DO NOT AUTOCLAVE THE WHOLE MICROMOTOR!
DO NOT SOAK THE MICROMOTOR DIRECTLY IN SOLUTION!**

Warning! Check the autoclave periodically according to the manufacturer's prescriptions!

TROUBLE SHOOTING

| PROBLEM | PROBABLE CAUSE | SUGGESTED SOLUTION |
|---|---|--|
| Motor fails to rotate and no voltage at hose exit | Burnt out fuse in power supply unit | Change fuse |
| | Power supply box failure | Seek technical assistance |
| | Supply line failure | Seek technical assistance |
| Motor fails to rotate but there is voltage at hose exit | Motor is stuck | Seek technical assistance |
| | Handpiece is stuck | Remove, clean and grease handpiece. Send handpiece to manufacturer |
| Motor rotates, but speed cannot be regulated | Foot control potentiometer failure | Change potentiometer Seek technical assistance |
| | Stabilized power supply unit failure | Seek technical assistance |
| Motor run is intermittent | Supply cable failure | Change supply cable |
| | Damaged bearings | Seek technical assistance |
| Motor fails to provide sufficient power | Power supply unit failure / Motor failure | Seek technical assistance |
| The motor heats up too much | Inadequate cooling air | Seek technical assistance |
| Only the motor rotates but not the bur | Handpiece is fitted incorrectly | Remove handpiece and re-fit correctly |
| | Handpiece is broken-down | Send handpiece to manufacturer |
| | Connection joint damaged | Seek technical assistance |
| Handpiece rotates on its attachment | Handpiece is stuck | Remove, clean and grease handpiece. Send handpiece to manufacturer |
| Handpiece cannot be locked on the connection stem | Handpiece damaged | Change handpiece |
| | Latch damaged | Seek technical assistance |
| Water leakage from handpiece | Worn or damaged seal rings | Change the rings or seek technical assistance |
| Water leakage from pipe connection | Worn or damaged seal rings | Change the rings or seek technical assistance |

IMPORTANT

**WE PRESCRIBE TO:
STOP WORKING IMMEDIATELY IN THE EVENT OF UNUSUAL NOISE, STRONG VIBRATION
OR IF BUR IS NOT KEPT FIRMLY IN POSITION.**

"PIEZOSTERIL 5" - "PIEZOLIGHT 5" SCALER HANDPIECE

GENERAL TECHNICAL DATA

| | |
|------------------------|---|
| Electrical supply | 32 VDC |
| Max Input power | 15 W |
| Frequency | 25.000 ÷ 32.000 Hz |
| Intermittent operation | 20 min work – 10 min stand-by |
| Water supply | 90 ÷ 140 kPa (0,9 ÷ 1,4 bar) at the exit of the syringe |
| Classification: | IIa (93/42 EEC Directive) |

WARNING!

- Before every use check that the tip is correctly locked on the handpiece (see section "USING THE HANDPIECE").
- Cool the operating area conveniently!
- Do not use the instrument if the tip or handpiece are visibly damaged or if unusual noises and/or vibrations are produced. Contact an authorised technical service centre.
- For the use of this instrument the rubber dam must be applied on the patient. In treatment procedures with tips that do not allow application of a dam, the patient must be instructed to breathe through his/her nose during treatment.
- High frequency ultrasonic vibrations may interfere with pace-maker operation. Before treating pace-maker carriers, consult the pace-maker manufacturer.
- During the working, this unit will not cause radio interference to the electric network.

USING SAFELY: rules and recommendations

To ensure that the equipment is used safely, the user must abide by the set standards of hygiene and professional diligence.

The following points should also be kept in mind:

- During use, dust and fragments of material from the patient's mouth or the device being used may be thrust into the surrounding environment (organic and inorganic particles, metal dust, liquids, potentially infected fluids and biological materials): **personnel must duly protect their eyes, breathing passages, mouth and skin** by wearing safety glasses, face shields, masks and disposable gloves.
- Operate the suction system at high speed in all operations likely to result in a discharge of materials, dust and aerosols to minimise their dissemination.

N.B.: it is not advisable to use drinking water to supply the dental unit, since it may lead to the formation of a biofilm in the waterlines and thus facilitate germ proliferation inside the unit itself; **It is recommended to supply the unit exclusively with dedicated liquids** (Isotonic Saline Solution or I.P.Purified Water) using the Separate Supply system.

after use on each patient:

The handpiece, tips and wrench must be sterilised in a steam autoclave at 135°C, 2.1 bars, after their surfaces have been washed and disinfected (see specific instructions).

The hygienic procedures described in this manual in the section on "Cleaning, Disinfection and Sterilisation" **must be regularly implemented.**

All the operations described in this section must be carried out wearing disposable protective gloves.



Pict. 1 – Box for PIEZOSTERIL 5 sterilization

CONNECTION OF THE SCALER

The scaler must be fitted on its supply hose just by pushing it fully on the hose connector.

It's necessary to pay attention that the mating surfaces (1 and 2 - pict. 2) be clean and dry.

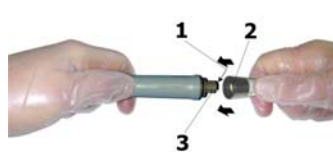

Pict. 2 – Connection to the supply hose

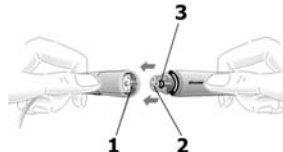

Pict. 2 – Connection to the supply hose

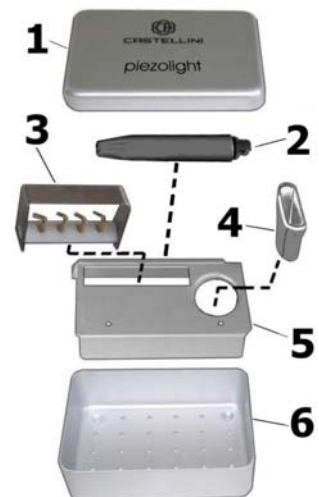

Pict. 1 – Box for PIEZOLIGHT 5 sterilization

ELECTRICAL SUPPLY

The input for the scaler must be provided by the specific power supply circuit - assembled in the unit- and the relative cable and wiring.
Adjust the controls on the unit table to control power and water flow.
Liquid delivery is adjusted via the regulator applied on the instrument coupling (Pict.3).

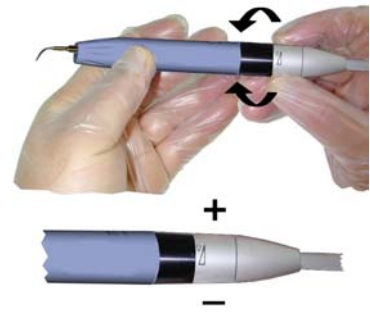

Pict. 3 – Regulation of water flow

HANDPIECE OPERATION

The scaler must be operated only with its proper tips (pict. 7), provided in the box.
The tips have to be screwed on exclusively by means of the proper dynamometric spanner, also provided in the box (4 - pict. 1).
The scaler has to be subjected to **intermittent operation** as follows: 20 min works, 10 min stand-by.
Irrigate abundantly during treatment. Do not operate in the absence of liquid.

When using specific tips for dry procedures, operate at intervals lasting no longer than 3 seconds.
Optimum performance is ensured at three quarter of maximum power. After having connected the handpiece to its hose, taking care to hold the handpiece in a vertical position. Run scaler for a few seconds with the tip held upwards until a constant spray is delivered. Water spray varies according to running power and tip.
The handpiece with tip **C1 must not** be operated perpendicularly to the tooth or from the front, but rather tangentially (as shown in pict. 6). Applying slight lateral pressure, move the handpiece back and forth as if erasing with a rubber.

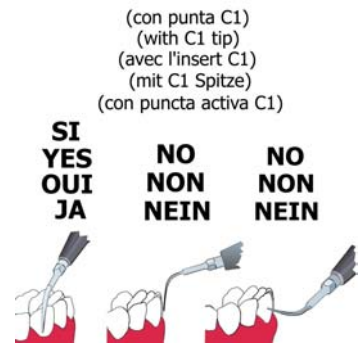

Pict. 6 – How to operate with the tips

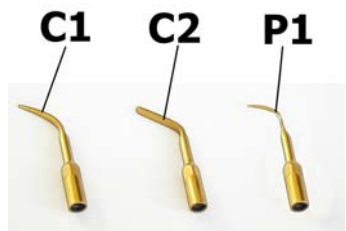

Pict. 7 - Tips provided in the box

It is thus ABSOLUTELY ESSENTIAL to replace worn or damaged tips.

DO NOT CHANGE the structure of the tips by bending or filing them!

WARNING: Do not use the handpiece on metal or ceramic fixtures. The high-frequency oscillations may damage them.

LIGHTING DEVICE (only for Piezolight 5)

The halogen bulb housed in the hose connection must be powered at a maximum of 3.5 Vdc. It must never be touched with bare hands: should this occur accidentally, clean it with a cotton wad dipped in alcohol.

To replace the bulb (pict. 4), disconnect the handpiece from the hose and, with the aid of a pointed tool, gently pry the bulb from the hose connection. Insert a new bulb, taking care to line up its contacts with those in the socket: the bulb can be fitted properly only in this position. **N.B.: The bulb life is approximately 50 hours**

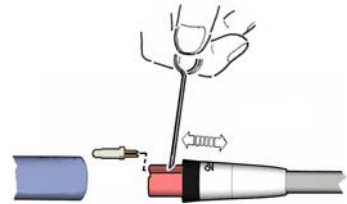

Pict. 4 – Replacement of the bulb

FITTING TIPS INTO THE PIEZOLIGHT 5

After screwing in the tip, continue turning the wrench until the arrow on the wrench itself is aligned with the notch on the front end of the handpiece (pict. 5).

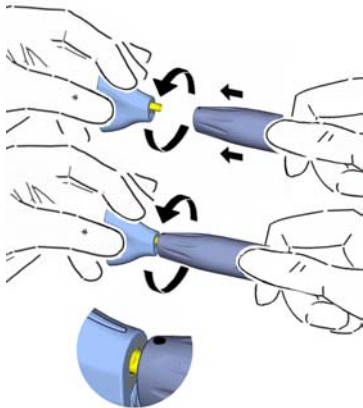

Pict. 5 – How to fit tips into the handpiece

SERVICING

It is requested a weekly lubrication of the O-ring on the water connection (3 - pict. 2), by means of the proper S1 silicon lubricant distributed by Castellini S.p.A. Wearing protective disposable gloves, apply a small amount of S1 on fingers and lubricate by it. Screw off a tip at least once a month to prevent autolocking.

CLEANING, DISINFECTING, STERILIZING

ATTENTION: The instrument is supplied not sterile.

Before use sterilize according to the following specifications. Prima Use gauze or cotton soaked in ethyl alcohol at 70% to clean and/or disinfect handpiece exterior. Do not use an ultrasonic cleaner. **Do not soak a scaler directly in solution.**

Scaler tips may be disinfected by immersion in ethyl alcohol at 70% Clean and disinfect handpiece and tips before sterilizing. Clean tips with running water before sterilizing.

The scaler must be sterilized in **autoclave** with water steam up to **135 °C 210 kPa (2.1 bar) for 20 min.** Never sterilize it in dry-heat sterilizer.

When sterilizing the handpiece, take care the tip has been removed.

Never leave a scaler in autoclave, always remove it from autoclave after each cycle.

In the same way it's possible to sterilize tips, tips-holder, spanner and the whole box.

**Warning! Check the autoclave periodically according to the manufacturer's prescriptions!
Temperature exceeding the above stated limit may damage the handpiece!**

TROUBLESHOOTING

| | |
|----------------------|--|
| Unsatisfactory power | <p>Be sure that the handpiece is correctly fitted on its hose</p> <p>Check the setting of the power control on the unit table</p> <p>Be sure that tip is screwed on properly</p> <p>Check that tip is not worn out</p> <p>Ask for Technical Assistance</p> |
| No vibration | <p>Do not insist with foot-control</p> <p>Ask for Technical Assistance</p> |
| Poor water flow | <p>Check the setting of the water control on the unit table or on the hose connection</p> <p>Be sure that water passage on the tip is not clogged.</p> <p>Eventually blow it with air by means of the syringe</p> <p>Ask for Technical Assistance</p> |

"LEDA" POLYMERIZING LAMP

GENERAL TECHNICAL DATA

| | |
|------------------------|---|
| Power supply | 32 VDC |
| Max electrical input | 10.5 W |
| Light source | 1 LED 5 W |
| Wavelength | 440-480 nm |
| Curing time settings | 20 – 40 – 60 s |
| Intermittent operation | 60 seconds of operation / 13 minutes rest |
| Acoustic signals | at the start, every 5 s and end of curing cycle |
| Thermal protection | against overheating |
| Electrical protection | Standards CEI EN 60601-1 and CEI EN 60601-1-2 |
| Classification | IIa (93/42 EEC Directive) |

CONNECTING THE HANDPIECE AND FIBRE OPTIC LIGHT GUIDE (Pict. 1)

The LEDA curing lamp must be fitted to the power cord simply by pushing it into place (see Pict. 1). The connecting surfaces must be clean and dry.

The fibre optic guide, rotatable by 360°, must always be inserted all the way in to avoid losses in efficiency.

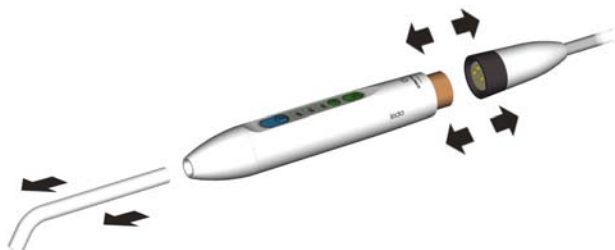

Pict. 1 – Connecting the handpiece and fibre optic guide

PRELIMINARY STEPS

Before using the lamp for the first time, carry out the following steps:

- clean and disinfect the handpiece;
- sterilise the fibre optic guide, which is supplied in a non-sterile condition (see Cleaning, Disinfection and Sterilisation instructions below).

USING SAFELY: rules and recommendations

For safe use of the device, it is important to observe the current standards of hygiene and good professional practice.

We also draw attention to the following rules:

- do not use the device in the presence of flammable substances;
- the device must not be used on patients or by users who have been fitted with pacemakers or other implantable devices;
- do not use the device on patients who are undergoing treatment with photosensitising drugs;
- never aim the light beam toward the eyes; special care should be taken and suitable protective eyewear should be provided for patients who are particularly sensitive or have undergone cataract surgery or have a clinical history of retinal disease;
- protect eyes adequately by wearing glasses, full face shield;
During use wear a suitable protective shield (available from Castellini, order code L0001225) or filter glasses providing protection against blue light up to a wavelength of 520 nm, available from distributors of dental supplies.
- do not aim the light beam at soft tissues (gums, mucous membrane or skin) since overexposure may cause irritation. The fibre optic guide should be positioned directly over the material to be cured;
- while carrying out cleaning and disinfection operations take care that no cleaning agent gets inside the device.

After use on each patient:

it is mandatory to sterilise the fibre optic guide in a steam autoclave at 135°C and 2.1 bars, after the surface has been cleaned and disinfected.

The hygienic maintenance procedures described herein in the section on "Cleaning, Disinfection and Sterilisation" **must be routinely applied. Do not use the device if it is damaged. Contact an authorised Service Centre. Suspend operation immediately if the device becomes abnormally hot.**

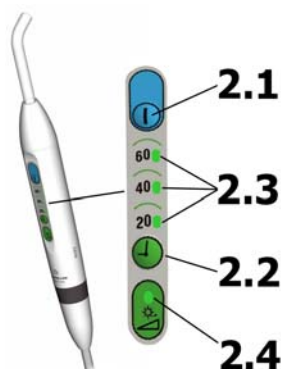

Pict. 2 - Overall view

USING THE HANDPIECE

The wavelength of the light emitted by the device falls within the range of 440 - 480 nm, suitable for the majority of composites. When in doubt, refer to the composite specifications or contact the manufacturer.

The device is designed to **work intermittently**: 60 seconds of operation, 13 minutes of rest.

After connecting the handpiece to the power cord and inserting the fibre optic guide, select the desired curing time by pressing and instantly releasing the button (2.2 - Pict. 2) in sequence: the selected setting will be indicated by the lighting up of the corresponding LED (2.3 - Pict. 2).

Pressing the button (2.2) longer will not change the time setting but will rather activate the light intensity ramp-up mode, as signalled by the lighting up of the corresponding LED (2.4). To deactivate the ramp-up mode, press the button (2.2) and keep it pressed until LED (2.4) goes off.

To turn on the lamp, press the button (2.1 - Pict. 2). As long as the button is pressed the device will emit light for targeting only; releasing the button will activate the curing light.

The light goes off automatically when the set time has elapsed and emits an audible signal (3 beeps in rapid sequence).

The lamp can be turned off before the set time has elapsed by pressing the button again (2.1 - Pict. 2).

During operation a beep will be emitted every 5 s.

A safety device shuts off the lamp if the temperatures exceed the limits established by applicable safety standards. It will be necessary to wait for the lamp to cool down before resuming operation.

When the instrument is disabled due to overtemperature the lighted LEDs will flash.

DO NOT USE when the fibre optic guide is damaged!

The only on-site servicing possible is replacement of the fibre optic guide.

MAINTENANCE

Keep the fibre optic guide clean. Carry out cleaning, disinfection and sterilisation on a routine basis as described below.

CLEANING, DISINFECTION AND STERILIZATION

WARNING: The instrument is supplied in a non-sterile condition.

Before use, sterilise it according to the directions provided below.

It shall be pointed out that the decree issued by the Italian Health Ministry on 28 September 1990 and published in the Official Gazette, n° 235 of 8/10/90, explicitly provides that reusable dental instruments coming into contact with the mucous membrane must be sterilised or disinfected, where sterilisation is not possible, after use on each patient. The optical guide and handpiece casing can be cleaned with Ster 1 Plus and disinfected using a cotton wad dipped in 70% ethyl alcohol.

All operations described in this section must be performed wearing disposable protective gloves.

Cleaning may be carried out only when the handpiece is cold and care must be taken to prevent liquids from getting inside the handpiece.

The optical guide and handpiece casing can be cleaned with Ster 1 Plus and disinfected using a cotton wad dipped in surgical alcohol.

Cleaning may be carried out only when the handpiece is cold and care must be taken to prevent liquids from getting inside the handpiece.

To prevent lamp efficiency from being impaired, keep the fibre optic guide clean and avoid direct contact with restoration materials. Remove any scale without using sharp or pointed tools which may damage the surface.

Only the fibre optic guide can be sterilised and **exclusively in an autoclave** at a temperature of up to 135°C and pressure of 210 kPa (2.1 bars) for 20 min. Always clean the fibre optic guide before sterilising it.

DO NOT AUTOCLAVE THE WHOLE HANDPIECE!

Warning! Periodically check the autoclave according to the manufacturer's directions!

Temperatures beyond the stated limit may damage the optic fibre!

TROUBLESHOOTING

| | |
|--|---|
| Limited curing capacity | Check that the fibre optic guide is clean and intact Request assistance from Service Personnel |
| The lamp goes off before the cycle has ended (*) | The thermal protector has tripped. Allow the lamp to cool down. |

(*) it's lighting intermittently the pre-selected setting time led

PAGE WITHOUT TEXT



Puma Evo

PART IV – **INSTRUCTIONS FOR THE INSTALLATION**

ESSENTIAL REQUIREMENTS

PREMISE

THIS EQUIPMENT MUST BE INSTALLED only by specially trained and qualified technicians, carrying a valid "Authorised Castellini Technician" identification card.

The use of persons not meeting the above requirements, or in possession of an expired Castellini identification card, will automatically and immediately invalidate the equipment guarantee and all certifications, exonerating Castellini from any form of responsibility and transferring it de iure et de facto onto the person responsible for the operation, together with any criminal or civil proceedings undertaken by Castellini and claims for any damages suffered by third parties, including any further and/or greater damages.

The specially trained and qualified technician, carrying a valid Castellini identification card must not make alterations without prior authorisation, arbitrarily tamper or incorrectly carry out maintenance operations (i.e., not in compliance with the instructions issued by Castellini itself) and must not use non-original spare parts and/or components, nor connect Castellini products to any medical devices not approved by Castellini or not in compliance with the compatibility parameters specified by Castellini itself.

The specially trained and qualified technician, carrying a valid Castellini identification card is not authorised to alter or in any way interfere with the electric mains supply system as the law requires such operations to be carried out by specially authorised technical personnel (see applicable law)

Furthermore, no alterations or technical operations of any kind or nature may be performed on the water mains supply and water treatment systems or, generally, to the area in which the equipment is to be installed, as any works of this nature are the personal responsibility of the person legally responsible for the dental surgery (see "Important Warnings", page 4, Operator's Instructions).

Any violation of the above renders the identification card null and void and requires its immediate surrender to Castellini. Castellini reserve the right to undertake civil or criminal proceedings and to apply for compensation of any damages incurred, including any further and/or greater damages, notwithstanding any applicable legal sanctions.

The technician, as defined above, must be aware of the contents of the entire manual, including the section entitled "Operator Instructions" and must follow them scrupulously.



During installation, the technician must follow all the instructions and recommendations contained in this manual as well as the "**Installation Check-list**" attached to the equipment. The "**Installation Check-list**" must be signed by both the technician and the client.

The technician must also scrupulously fill in the documents and perform the duties for which he is competent, as described in the "**Installation Certificate**" attached to the equipment, signing the sections that concern him and asking the client and the sales personnel to sign those that concern them.

*A copy of the "**Installation Certificate**" and of the "**Installation Check-list**" must be forwarded to Castellini S.p.A. on the day the equipment is installed.

The technician must hand to the client a "**Malfunction/accident report**" form, inviting him to keep it safe and explaining that such form is to be used by technicians only to report any specific malfunction and/or accident to Castellini S.p.A.

The owner of the equipment is responsible for booking the services of the Castellini technician at all times.

The technician who performs the scheduled maintenance operations is responsible for correctly and accurately filling in the attached forms (see "Scheduled maintenance operations"), and must sign them, taking the responsibility for their accuracy upon himself.

The technician must explain to the user and any assistants how to use and maintain the device according to the directions provided herein.

The technician must thoroughly explain to the user and any assistants how to properly perform the maintenance operations described in the "*Protocol for Hygiene and Maintenance of Dental Unit*". (Also see, Protocol for Hygiene and Maintenance of the Castellini Dental Unit).

The technician must inform the user that all routine maintenance and sanitation of the dental unit must be performed exclusively with the products (lubricants included) specified by Castellini (see, "*Routine Maintenance Program*" and "*Products to be used with the Castellini Dental Unit*"). It is forbidden to use any product other than those explicitly named in this manual and in the "*Protocol for Hygiene and Maintenance of Dental Unit*".

* The equipment is fitted with an I.M.Q. certified, 10 A - 380 V power switch (to simultaneously separate the positive and negative poles).

The equipment **MUST** be fitted at source with a wall-mounted automatic differential switch manufactured in compliance with European standards, with a minimum of 16 A - 250 V and I Δ N differential power supply not above 0.03 A. Where the above mentioned switch is not already available, it must be fitted by personnel licensed to operate on the electricity mains supply system, in the manner and under the terms envisaged in the relevant laws.

The Manufacturer warns that any failure to comply with the above prescription will be considered improper use in contradiction with the manufacturer's directions and as a result will compromise the essential safety requisites prescribed by Directive 93/42 EEC, thereby invalidating the EC mark placed on the device.

Technicians are obliged to compile the **"Non-conformity Report"** form and send it to Castellini S.p.A.'s main office whenever they observe:

- that other medical devices and/or accessories not authorised by Castellini, or in any case outside the specifications of compatibility indicated by Castellini S.p.A., have been connected to Castellini products;
- evidence of unauthorised modifications, arbitrary tampering or maintenance work not complying with the directions provided by Castellini;
- evidence of previous use of non-original spare parts and/or components.

* The dental unit **MUST** be provided with an earth connection in compliance with BS standard.

* The dental unit is designed to be permanently connected to the power mains, by means of a suitable input terminal board.

* The safety fuse is inserted on the live pole (conductor with brown insulation sheath marked with wiremarker **L**). Access to the fuse (part. **4.3** – pict. 4) is only possible by means of a special screwdriver.

* In order to correctly connect the dental unit to the mains, the dentist's chair to the dental unit and, where applicable, the air extractor to the dental unit, follow instructions at the pictures 1.1, 1.2, 1.3, 1.4A, 1.4B, 1.5.

If the installation of an air compressor is required, separate power supply and protection device are necessary.

* Before proceeding with the installation the pipework should be thoroughly cleaned to avoid the penetration of any sediments in the water and compressed air circuit of the dental unit and the water pipes should be bled to eliminate any air bubbles.

* In order for the dental unit to work efficiently, it is essential that the room in which it is to be installed is adequately prepared, that care is taken in transporting special fittings, that all components are correctly installed and that the maintenance operations schedule recommended by the manufacturer is followed.

PERMITTED ENVIRONMENTAL CONDITIONS FOR TRANSPORT AND STORAGE

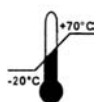

- Ambient temperature between - 20 ° and + 70 °C;

RH

- Relative humidity between 10 and 100 %;

P

- Atmospheric pressure between 500 and 1060 hPa (500 ÷ 1060 mbar).

- The appliance **MUST NOT** be removed from its packaging during transport and storage.

- After installation the first test operation must not be performed until the appliance has reached ambient operating temperature (10 ÷ 40 °C).

INSTALLING THE CHAIR AND THE UNIT

TRANSPORTATION OF THE CHAIR (Pict. A)

To convey the chair to the installation site more easily, it is recommended to use the carrying handles (1a), to be fitted onto the steel frame of the chair base using the safety screws (2a) and washers (3a) provided.

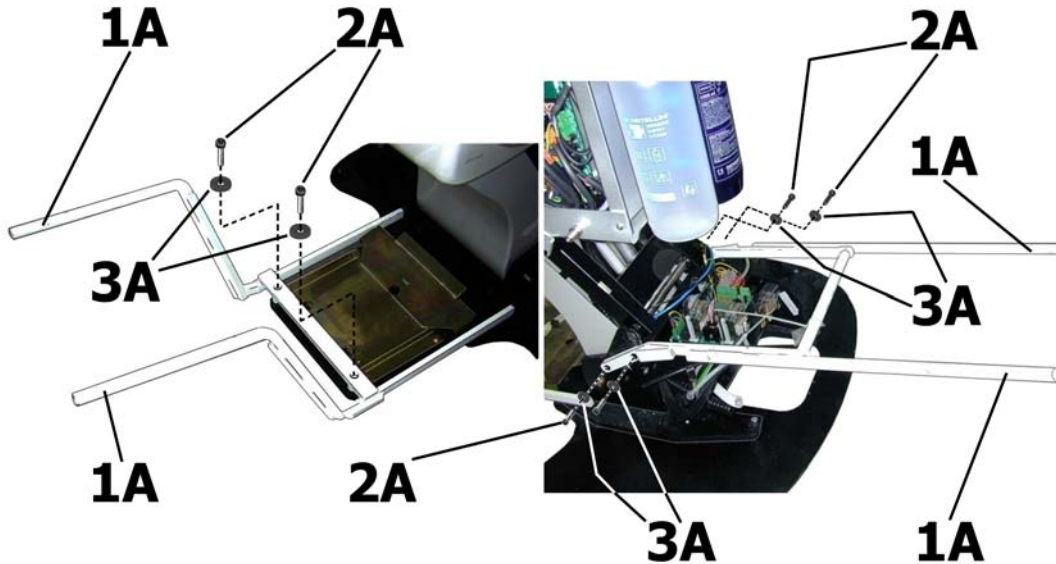

Pict. A – Chair transport with levers

INSTALLING THE CHAIR (Pict. B)



Pict. B – How to grip the chair

Tilt the mobile part of the seat and remove the covering casing at the base of the chair.

Position the chair according to the power supplies arranged on the floor of the surgery and fasten it using the screws with screw anchors provided (2 screws for right-hand unit or 3 screws for ambidextrous version).

In order to prevent probable damage during movements, avoid grasping the chair by the rear covering casing or by the front edge of the seat (legrest) (as indicated in pict. B above).

Grip the chair holding the top or bottom part of the articulated lifting arm only (as shown in pict. B below), or use specially designed lifting equipment (see pict. A).

We recommend reassembling the upholstery on the chair seat only once all unit installation operations are complete.

It is advisable to complete all the chair's installation steps before fitting the upholstery to the chair's seat.

LEVELLING THE CHAIR BASE (ambidextrous dental units only) (Pict. C)

The specific base (2) for the ambidextrous unit is sent separately from the chair. Having fixed it to the floor, use the six adjustment dowels (5 – pict. C) to give the platform a stable position even on slightly uneven floors.

Place the chair over it and fasten the base (1) using the six screws (3).

Assemble the unit body on the chair, then proceed as follows:

Check that the unit is level by placing a spirit level on the fixed horizontal arm of the dentist's tray, turning it first to the rest position and then to the work position.

- Tighten or loosen the adjustment dowels (4) to obtain a good level and the utmost stability of the chair on the floor (the instrument tray must remain stable in the position in which it is left).
- Lastly screw down the dowel (4a) to eliminate any gap between the two bases (1 and 2).

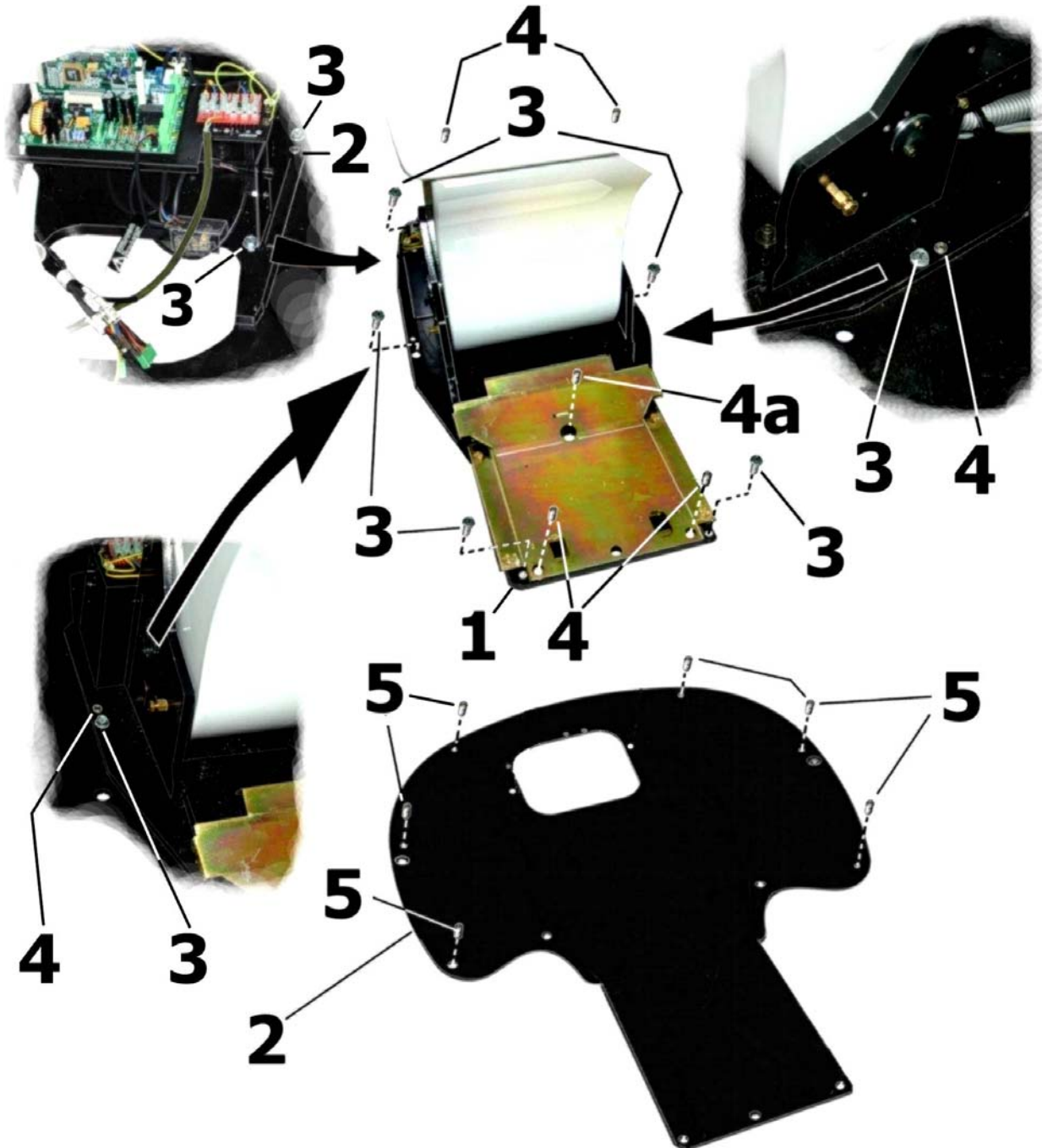

Pict. C – Levelling the chair base for ambidextrous unit

LEVELLING THE CHAIR BASE (right-hand dental units only) (Pict. C bis)

Having fixed the base to the floor (if possible) in the envisaged points indicated in picture C bis by the arrows (6), use the dowels (7) and, lastly, the dowel (8) to bring the underlying stainless steel plates into contact with the floor, thus guaranteeing utmost chair stability.

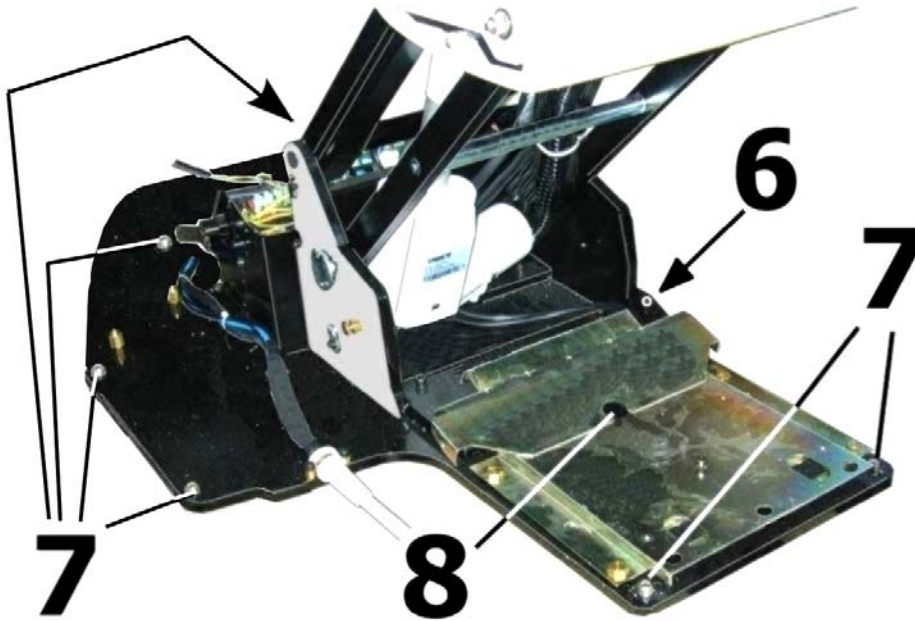

Pict. C bis – Levelling the chair base for right-hand unit

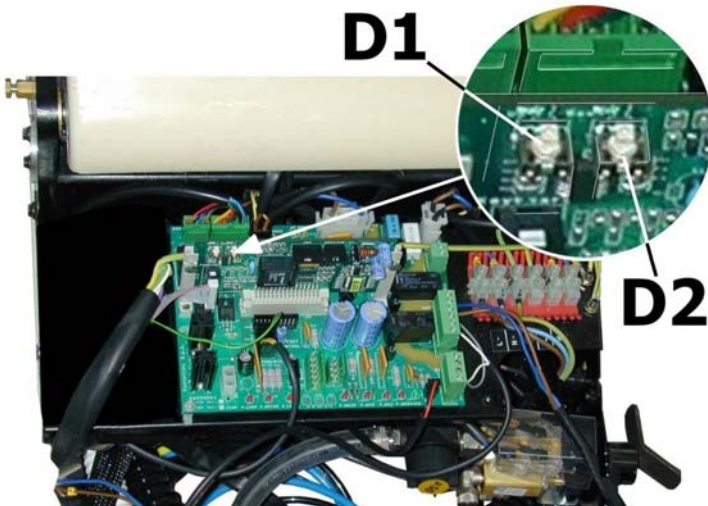

Pict. D – Controls for chair up and down

RAISING THE CHAIR (Pict. D)

To make the up/down movements of the chair seat (necessary during dental unit installation) more convenient to perform, two pushbuttons **D1** (up) and **D2** (down) are provided on the movement control card in the area indicated in pict. **D**.

Warning: pushbuttons **D1** and **D2** work with an extremely low safety voltage, but the main power terminals and main switch are powered with mains voltage.

INSTALLING THE RIGHT-HAND UNIT (Pict. C1)

Make sure that all pre-installation work has been performed according to the instructions shown on the 1:1 scale installation plan diagram and in this manual, then carry out the following operations in the stated order:

1) Using dolly (a), place crate containing the unit near the chair.

2) Remove the cover to open and take out all the accessories attached to the unit.

Caution: The safety binding that prevents the tray arm from rotating **MAY BE REMOVED ONLY AFTER** the dental unit has been completely fastened to the chair.

ATTENTION: the safety strap that prevents the arm of the dentist tray from turning **MAY ONLY BE REMOVED** once the unit has been fixed to the chair.

3) Remove the case of the power supply compartment and the two casing pieces from the articulated arm (c and i) in order to make the route to be followed by the cables to the floor visible when bringing the support (e) up to the attachment seat (f).

ATTENTION: the bundle of cables that comes out of the support (e) must pass over the cross member (m) that connects the two rods; only waste tubings have to pass across the sliding ring (part. B - Pict. C1).

4) Connect the chair to the electricity supply. One the trolley (a) has been positioned next to the chair, remove the bracket (d) from the plate (e) and rotate the unit on the pin (b) to bring the plate (e) parallel to the chair.

5) Position the chair attachment seat (f) at the same height as the plate (e), then bring the unit closer to the chair to make the plate (e) match with the attachment seat (f), passing the threaded pins through the holes (h) in the plate (e).

Before tightening the nuts all the way, level the dental unit, following the directions provided in the chap. "LEVELLING THE DENTAL UNIT"

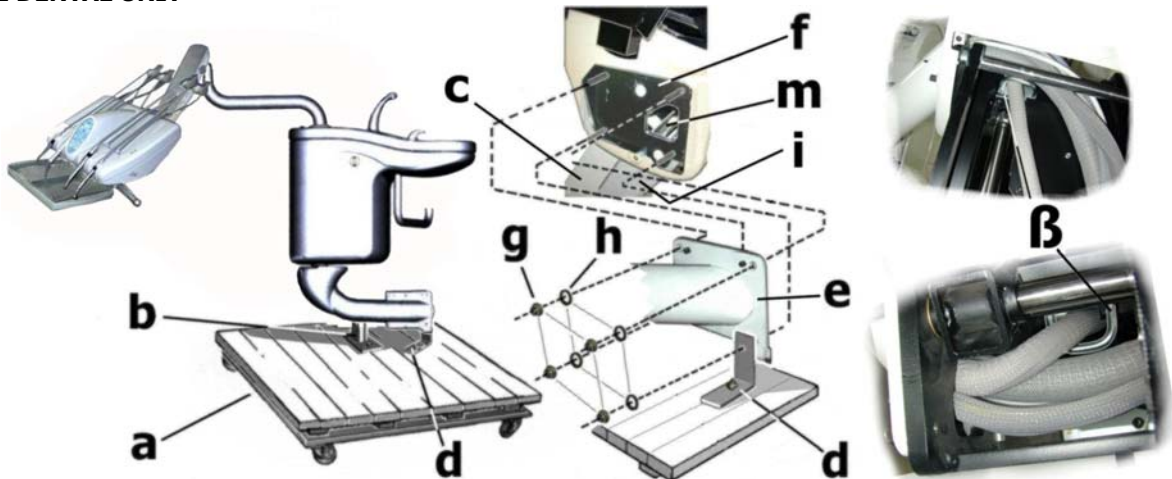

Pict. C1 – Installing the right-hand unit

LEVELLING THE UNIT (Pict. D1)

First check that the chair base is properly secured to the floor and the stand is set in working position. Now check that unit is perfectly flat by placing the level at point A then at point B.

Correct level at point A by tightening or loosening the dowel (C1); then thoroughly tighten the two nuts (A1).

Correct the level at point B by tightening one by one the two dowels (B1); then thoroughly tighten the two nuts (B2).

These steps are necessary when the floor is not perfectly level.

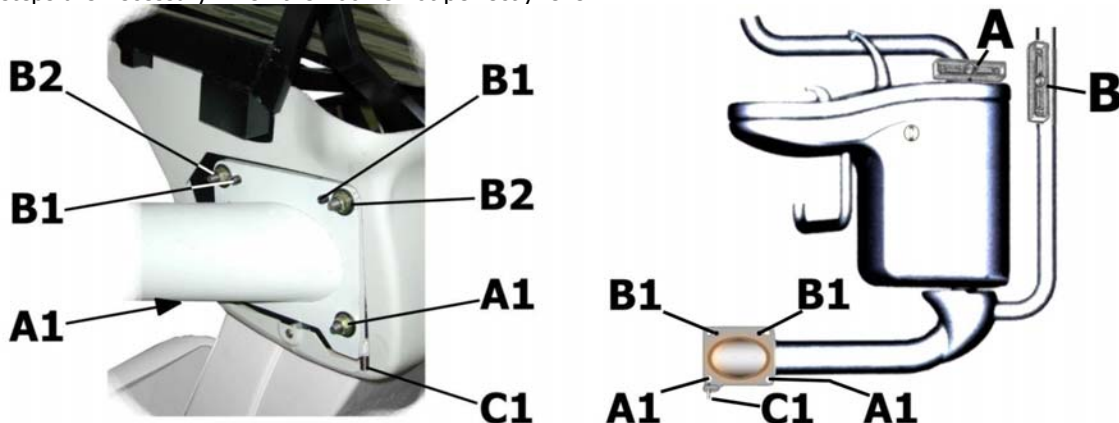

Pict. D1 – Levelling the right-hand unit

INSTALLING THE DENTAL UNIT (only ambidextrous units) (Picts. C2 – D2)

Having ensured that the installation work has been performed correctly according to the indications given in the 1:1 scale installation plan and in this manual, perform the following operations in order:

- 1) Using dolly (a), place crate containing the unit near the chair.
 - 2) Remove the cover to open and take out all the accessories attached to the unit.
- Caution:** The safety binding that prevents the tray arm from rotating **MAY BE REMOVED ONLY AFTER** the dental unit has been completely fastened to the chair.
- 3) Remove the casing on the supply compartment and the two casing pieces of the articulated arm (f and g) in order to make the route to be followed by the cables to reach the floor visible.
 - 4) Remove the protection (e) fastened with Velcro and the cable protection (j – pict. D2) then unscrew the four clamping screws (p) to remove the case (n). Disconnect the two connectors (r and s) to allow the removal of the seat.
 - 5) Remove the four seat clamping screws (h) and then raise the entire seat/backrest block.

Connect the chair to the electricity supply.

Picture C2 shows the sequence to be followed when bringing the platform closer in order to arrange the unit for connection to the chair.

Firstly, the fitter must loosen the nut (c), bringing the chair case closer and rotating the arm (i), on the pin (b) to take the trolley with the unit body as close as possible to the chair.

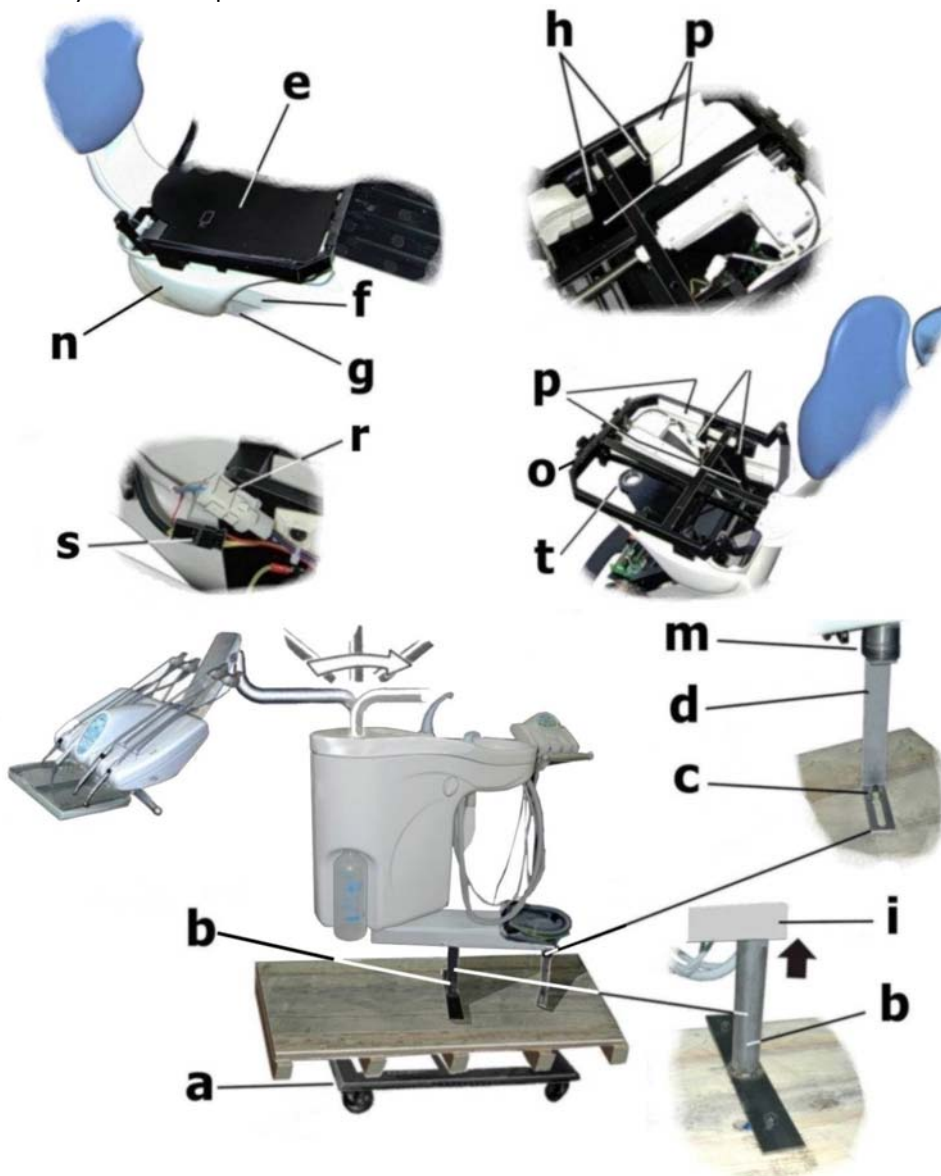

Pict. C2 – Levelling the ambidextrous unit

CONNECT THE AMBIDEXTROUS UNIT TO THE CHAIR (Pict. D2)

Completely lower the chair using the two buttons (D1 and D2 – pict. D) and proceed as follows:

- thread the cables and the hydraulic/pneumatic connections of the unit inside the chair;

ATTENTION: the bundle of cables that comes out of the support (e) must pass over the cross member (m) that connects the two rods.

- check the presence of the bearing and the thrust bearing ring (m) of the arm (i) in point (x), then bring the unit in to align the pin (m) with the hole on the fixing plate (t), then slowly raise the chair to thread the pin in completely;

- thread the thrust bearing ring (z) (with an interior diameter of $\text{Øi } 47$ mm) followed by the ball-support cage (v) and the second thrust bearing ring (u) (with an interior diameter of $\text{Øi } 45$ mm) onto the pin (m) and tighten the self-locking ring nut (w); rotate the arm (i) until the piston pin is engaged (n) in the support seat (t) and then tighten the ring nut until it abuts (w) using the wrench (y);

- before assembling the seat/backrest block ensure that the cable cover (j) is mounted correctly.

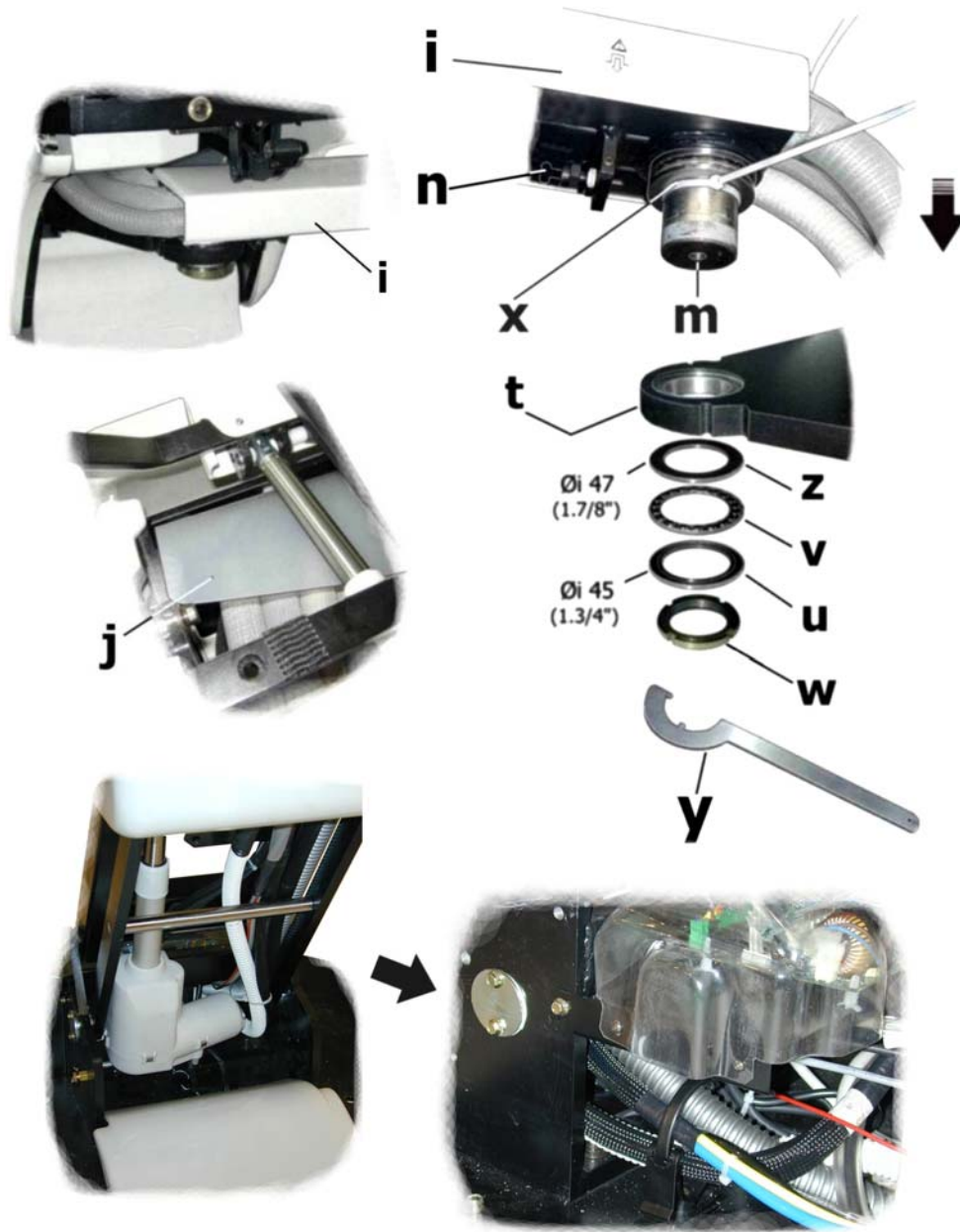

Pict. D2 – Connect the ambidextrous unit to the chair

INSTALLING THE UNIT'S FEED BOX (Picts. 1.1, 1.2 and 1.3)

The service technician is also to secure at installation the supply box and make the hydro-pneumatic and wiring connections as shown in Pict. 1.1, 1.2, 1.3

After disconnect the main power by the main switch, make the following operations:

- 1) Unscrew the three screws (part. **1.1.1** – pict. 1.1) and pull the protection (**1.1.2**); connect the main power cable, from the floor; to the three terminal of the main board (marked with "LINE" – pict. 1.3); the **brown** cable have to be connected to the terminal marked **L**~, the **blue** cable to the terminal **N**~, the **yellow/green** cable to the terminal  (see pict. 1.3);
- 2) Insert the connectors (**1.1.3** and **1.1.4** – pict. **1.1**) and (**1.4.10** and **1.4.11** – pict. **1.4A**) of the cables coming off from the proper seat on the electric circuit code E6000501, marked with **CN1 – CN14 – CN19 – CN20**.
- 3) Insert the water, pneumatic and discharge connections to the proper pipe fittings placed on the floor of the dental cabinet (see .picts. 1.5 and 1.1 and the installation plan by 1:1 scale).
- 4) Connect the foot control following the instruction by the chapter "FOOT PEDAL CONNECTIONS"
- 5) For connect the Unit to a centralized suction-system, see chapter "CONNECTION TO A SUCTION-SYSTEM".

Before making the under mentioned operations, mount again the protection (**1.1.2**) and fix it through the screws (**1.1.1**), then mount the cover (**1.8.1**) and fix it with the screw (**1.8.2** – pict. **1.8**)

CONNECTION FOR FOOT PEDAL (Picts. 1.4A - 1.4B and 1.5)

- Get up the unit to the maximum height; (**only for the ambidextrous version**) after mount the plastic cover of the chair base (**1.4.2**), insert through the preposed chair cover hole terminals (**1.4.8**) foot pedal cable and fairlead (**1.4.6**).
- Insert terminals (**1.4.8**) to the proper connections on the circuit E6000501, and then connect the three tubes (**1.5.1**, **1.5.2**, **1.5.3**), with the proper inserts, to the correspondent tubes connected to the unit (see pict. **1.5**).
- Connect the **yellow/green** cable fixing the ring-terminal cable (**1.4.13**) to one of the two heart-screws marked on pict. **1.1** with the bolt and the notched washer.
- Mount the cable clamp (**1.4.7**) under the fairlead (**1.4.6**) and fix it with proper screws (**1.4.9**) and then assemble the plastic cover (**1.4.2**), blocking it with screws (**1.4.3**).

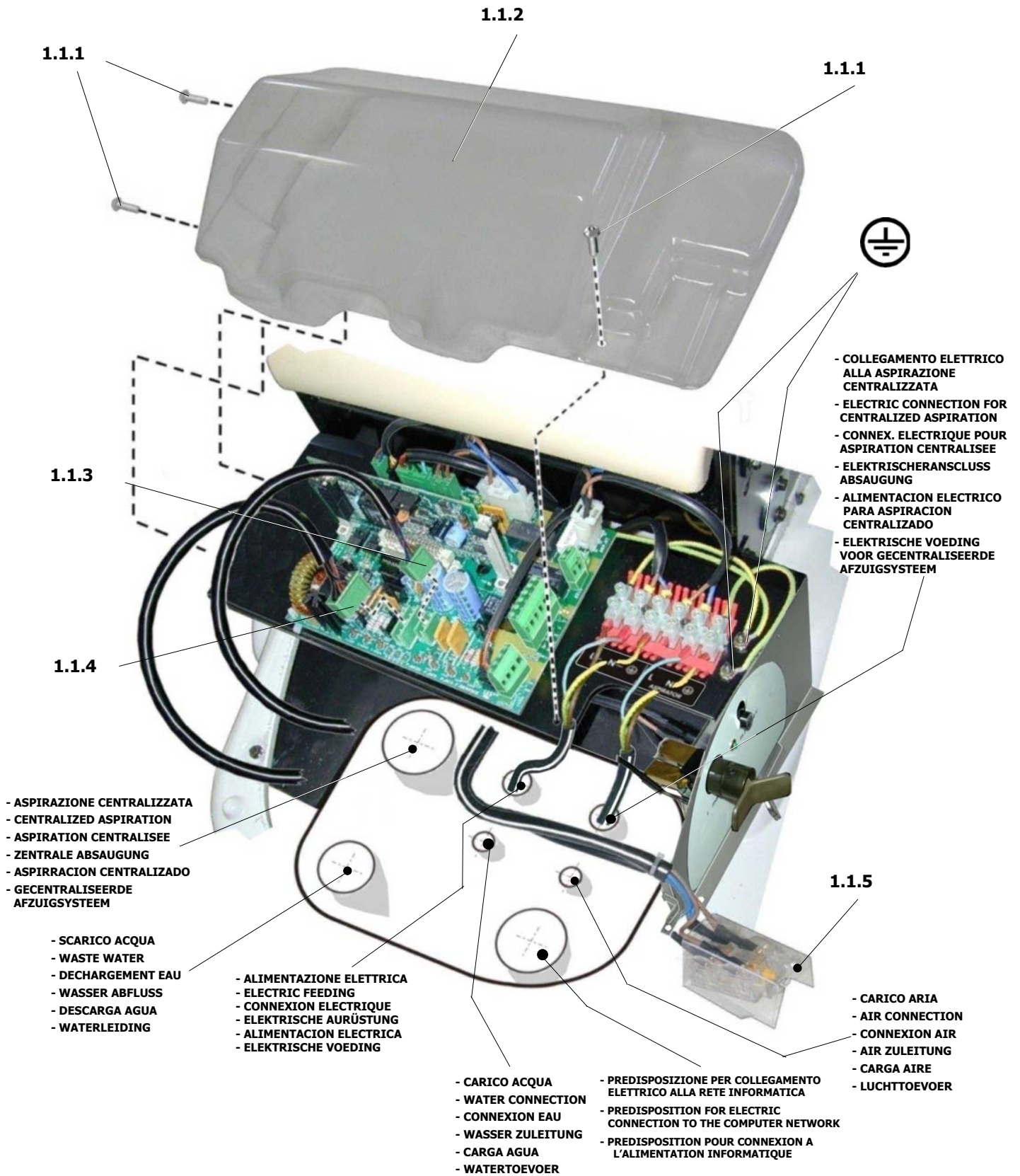

Pict. 1.1 – Feeding box – dental unit connections

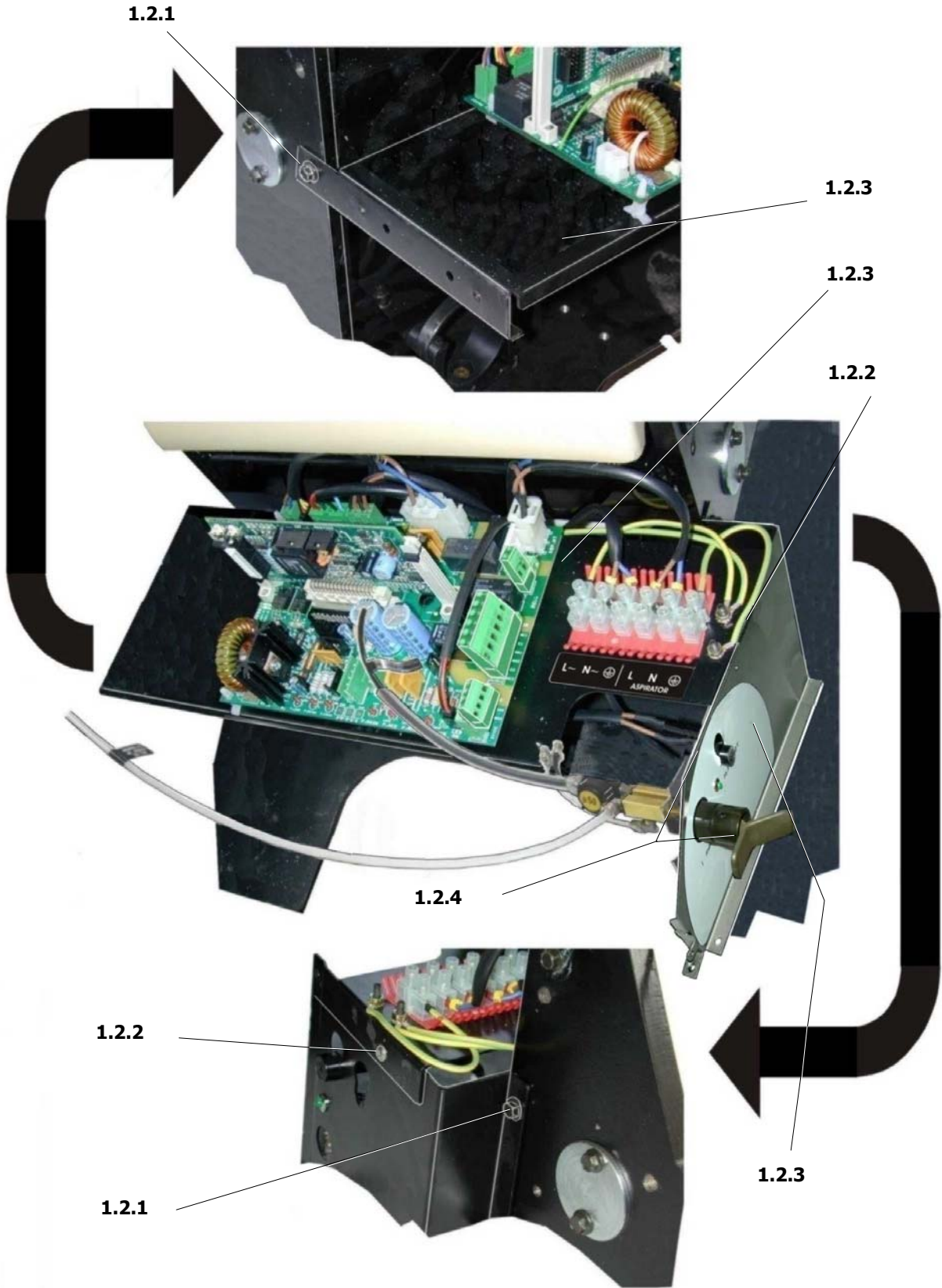

Pict. 1.2 – Feeding box – dental unit connections

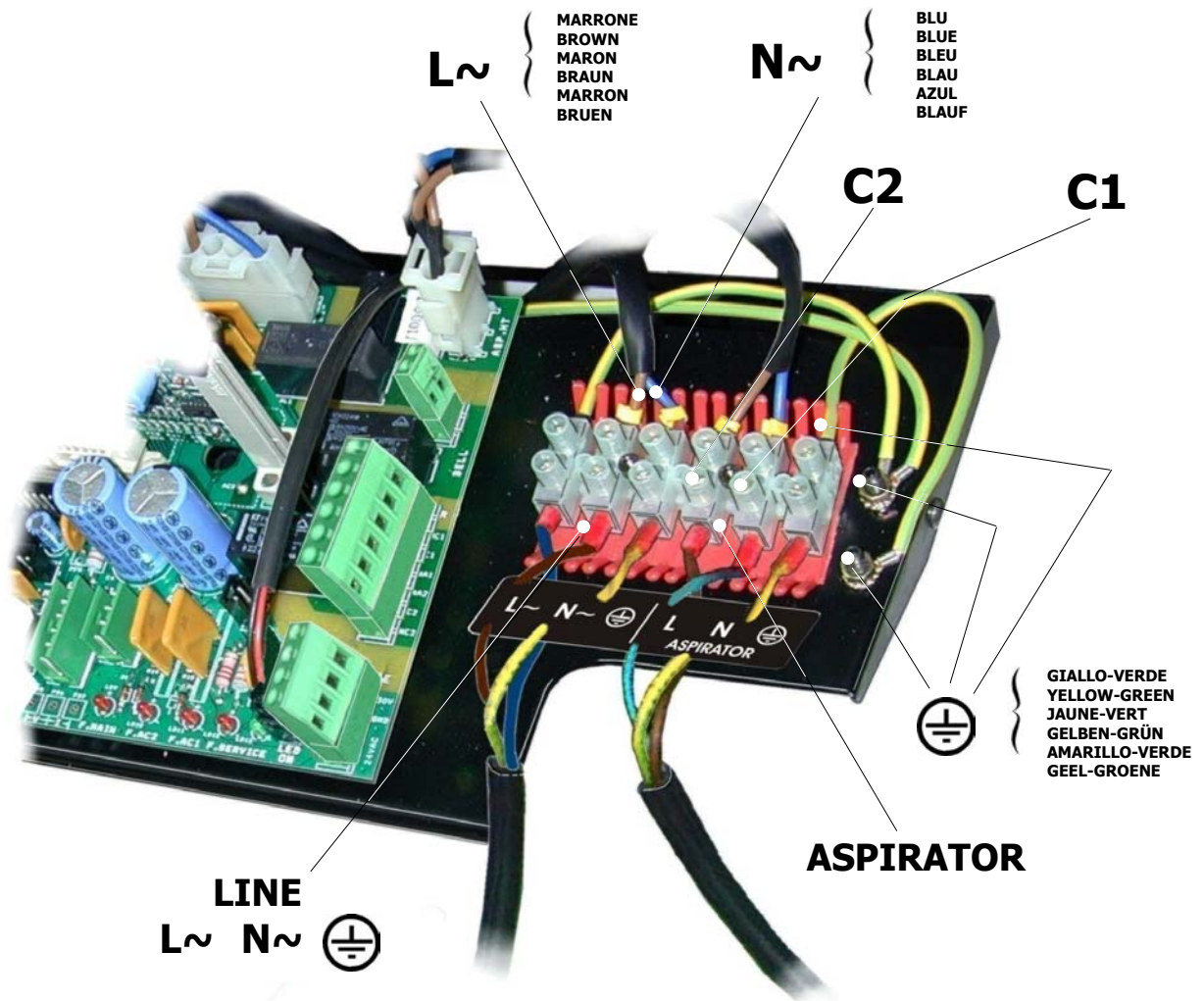

Pict. 1.3 – Feeding box electric connections

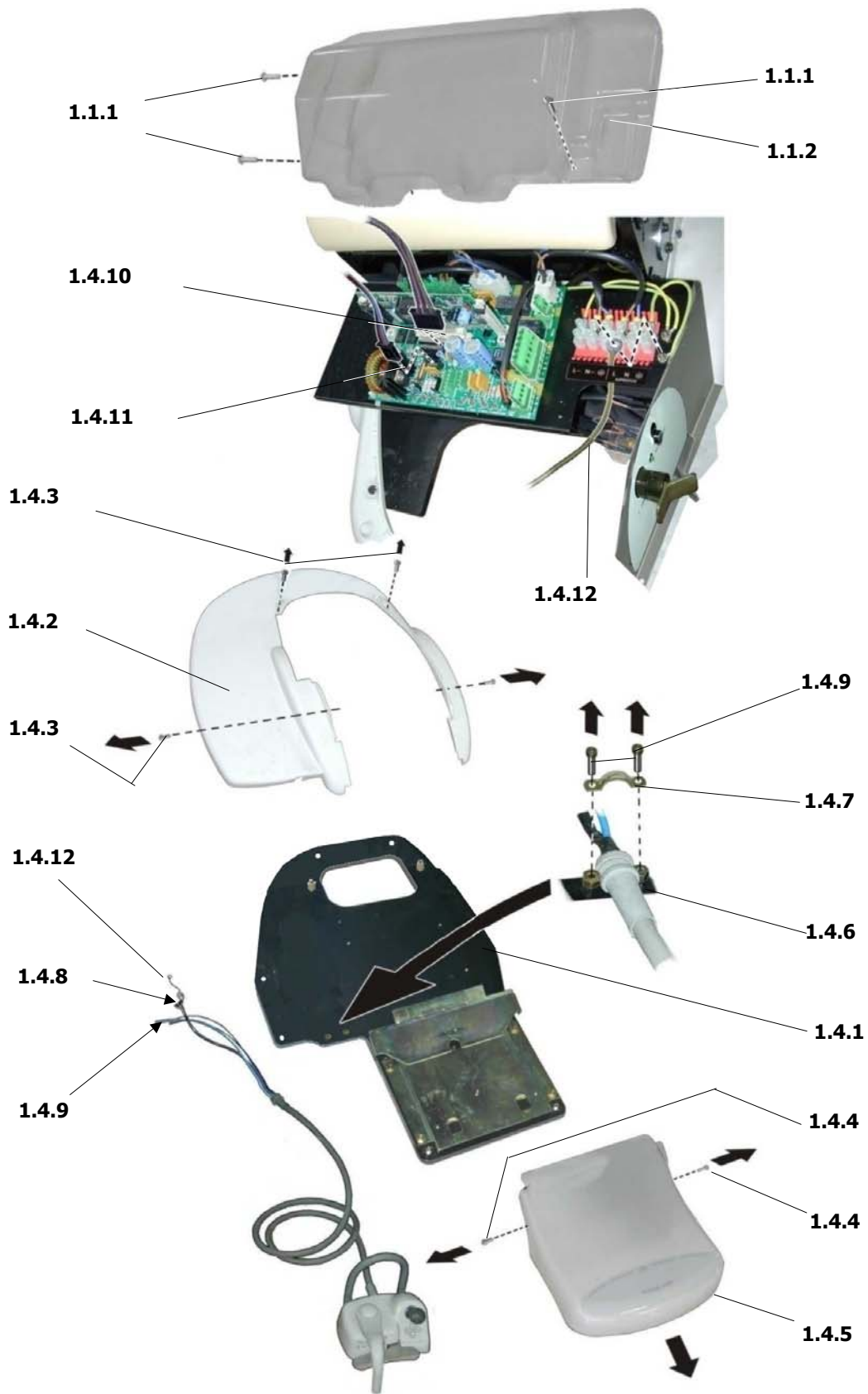

Pict. 1.4A - Foot control installation (right-hand unit)

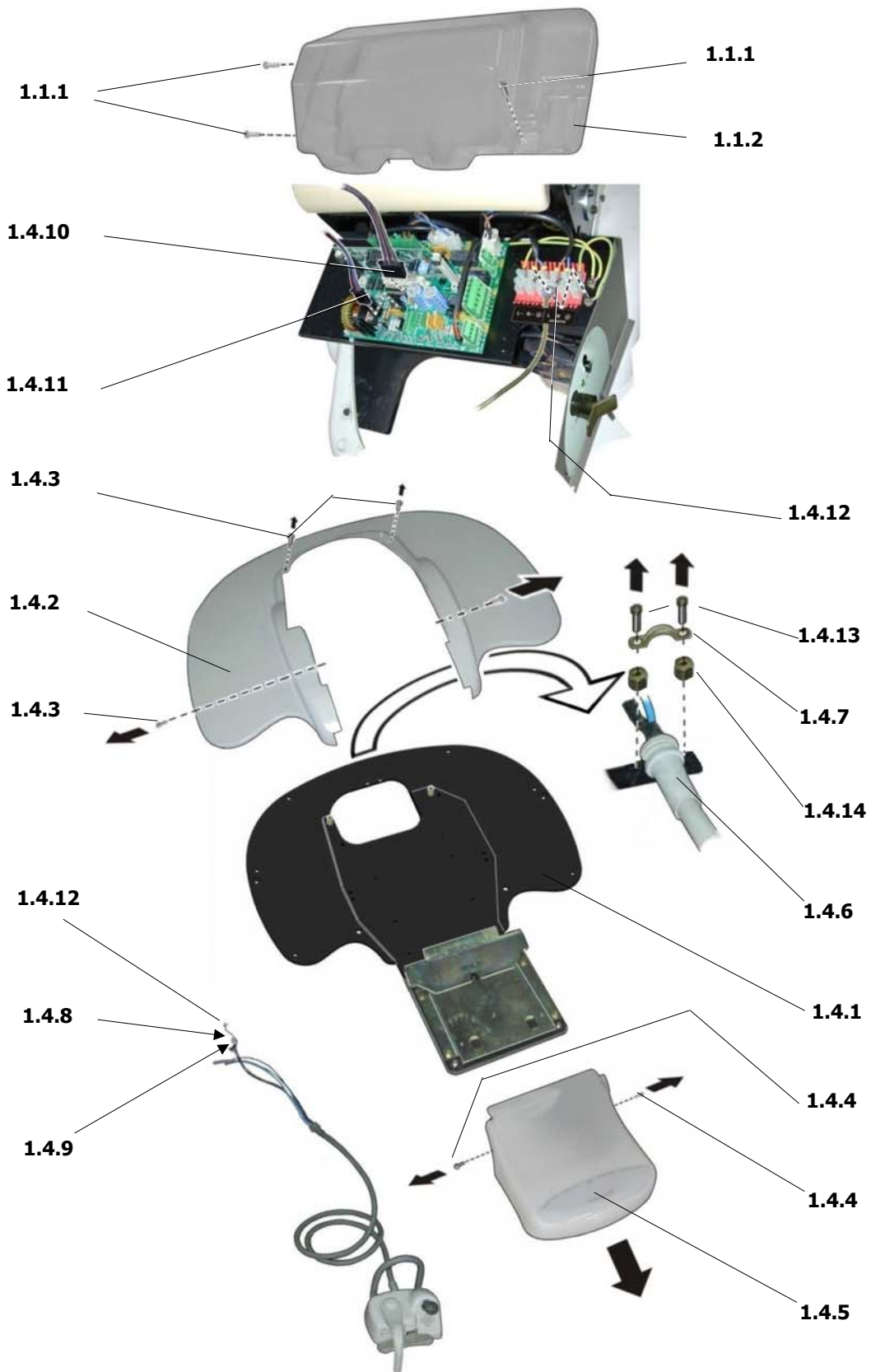

Pict. 1.4B - Foot control installation (ambidextrous unit)

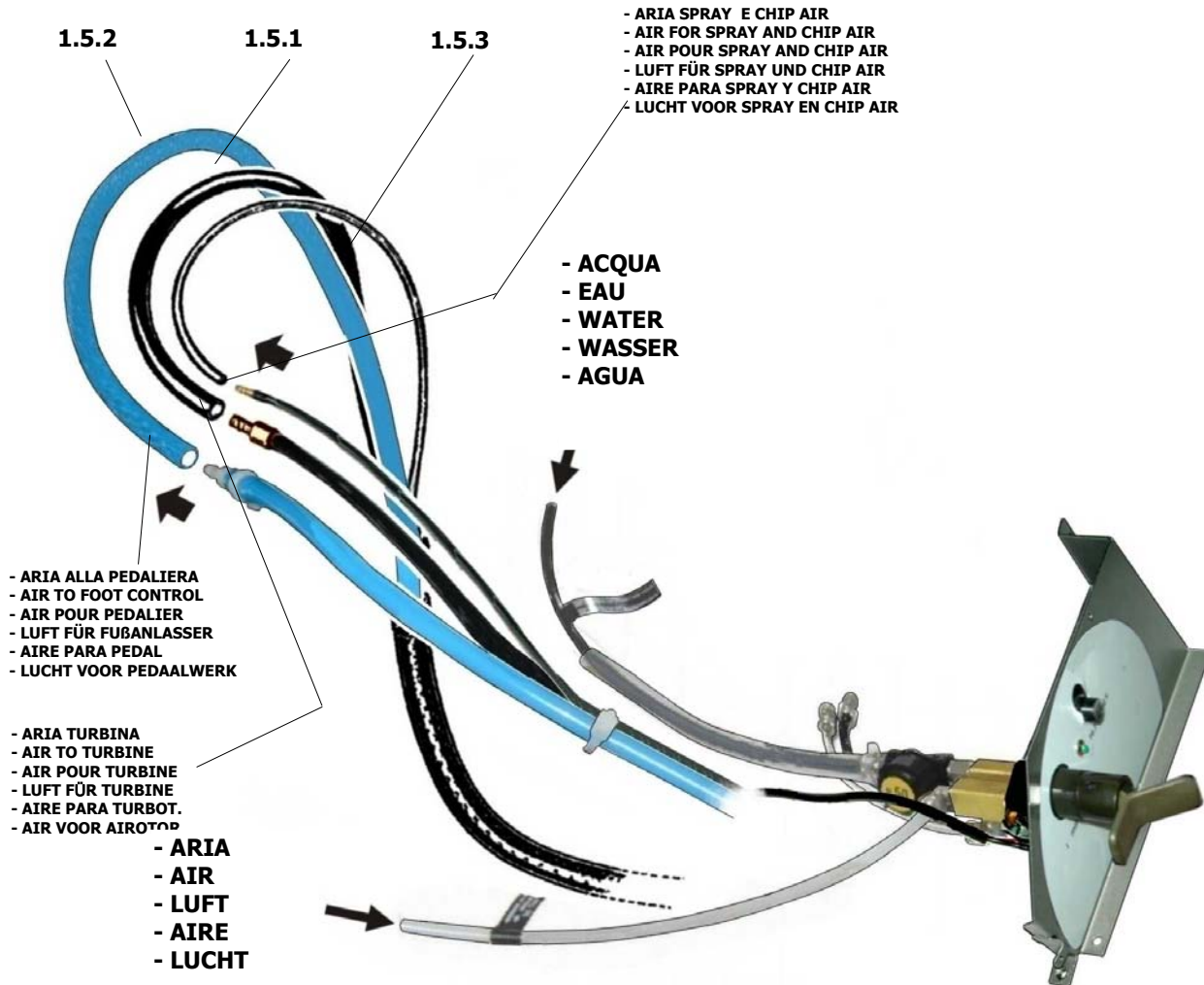

Pict. 1.5 – Foot control hydraulic connections

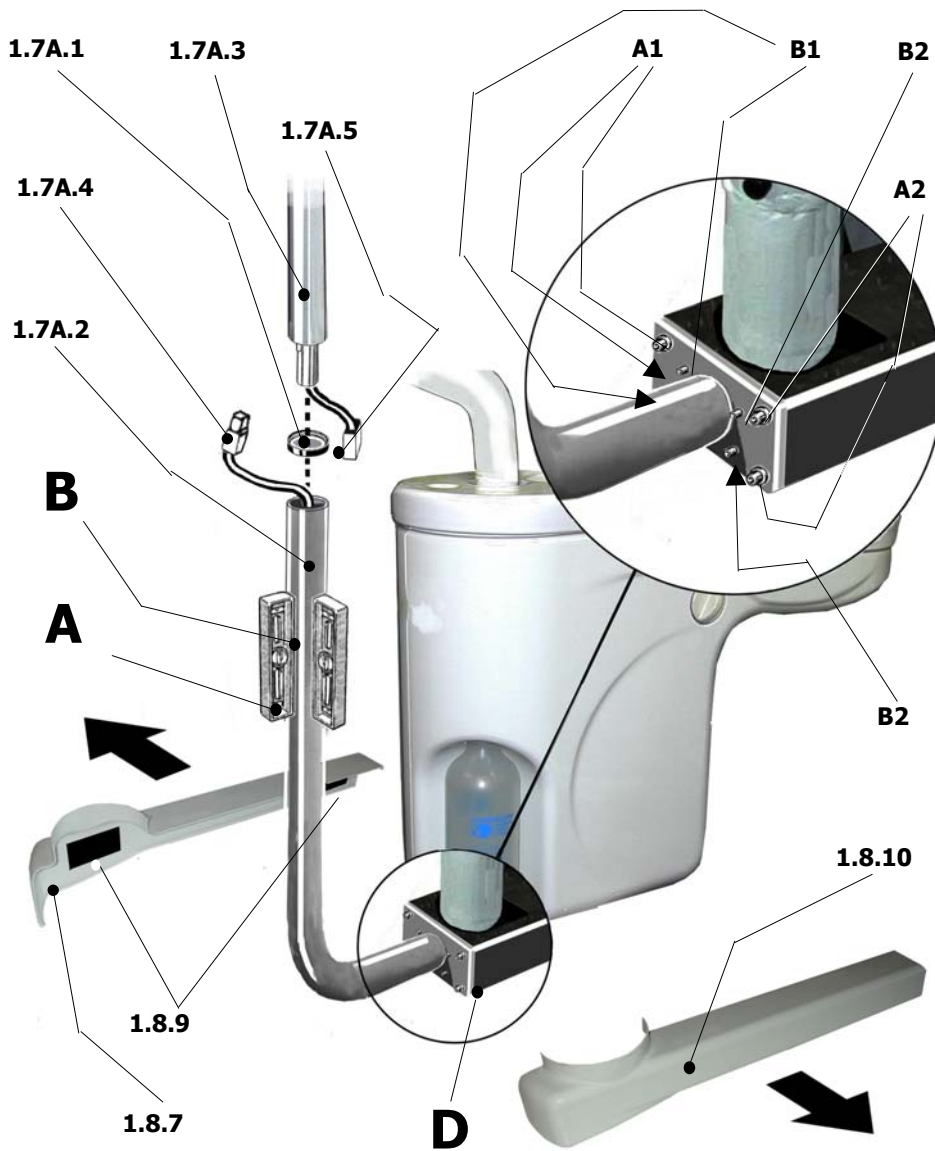

INSTALLING THE SCIALYTIC LAMP POST
(model for left+right handed dental unit) (Pict. 1.7A)

To access the area from which you can adjust the levelling of the scialytic lamp, proceed as follows:

- Remove the two half-covers of the rotation arm (**1.8.7** and **1.8.10** – Pict. 1.8A) by detaching the four Velcro inserts (**1.8.9** - Pict. 1.7A);
- After fitting the finishing ring (**1.7A.1**) on the lamp post (**1.7A.2**), connect the two connectors of the power cables (**1.7A.4** and **1.7A.5**) and insert the rotation pin of the lamp post (**1.7A.3**) into the arm (**1.7A.2**), taking care not to damage the cable.

Pict. 1.7A - Installing the scialytic lamp post (model for left+right handed dental unit)

LEVELLING THE SCIALYTIC LAMP INSTALLED ON THE DENTAL UNIT

After levelling the dental unit you must check whether the scialytic lamp is properly levelled by placing a spirit level first in point **A** and then in point **B**.

- To make a levelling adjustment at point **A**, set the lamp head in the working position and, after loosening the four screws (**A1** and **A2**), turn the support of the lamp post until achieving optimal levelling; then tighten only two of the screws (**A1**).
- To make a levelling adjustment at point **B**, adjust the tightness of the four grub screws (**B1** and **B2**) by tightening or loosening them in relation to the head of the rotation arm of the dental unit (**D**).
- Then firmly tighten the two screws (**A2**) together with the other screws (**A1**).

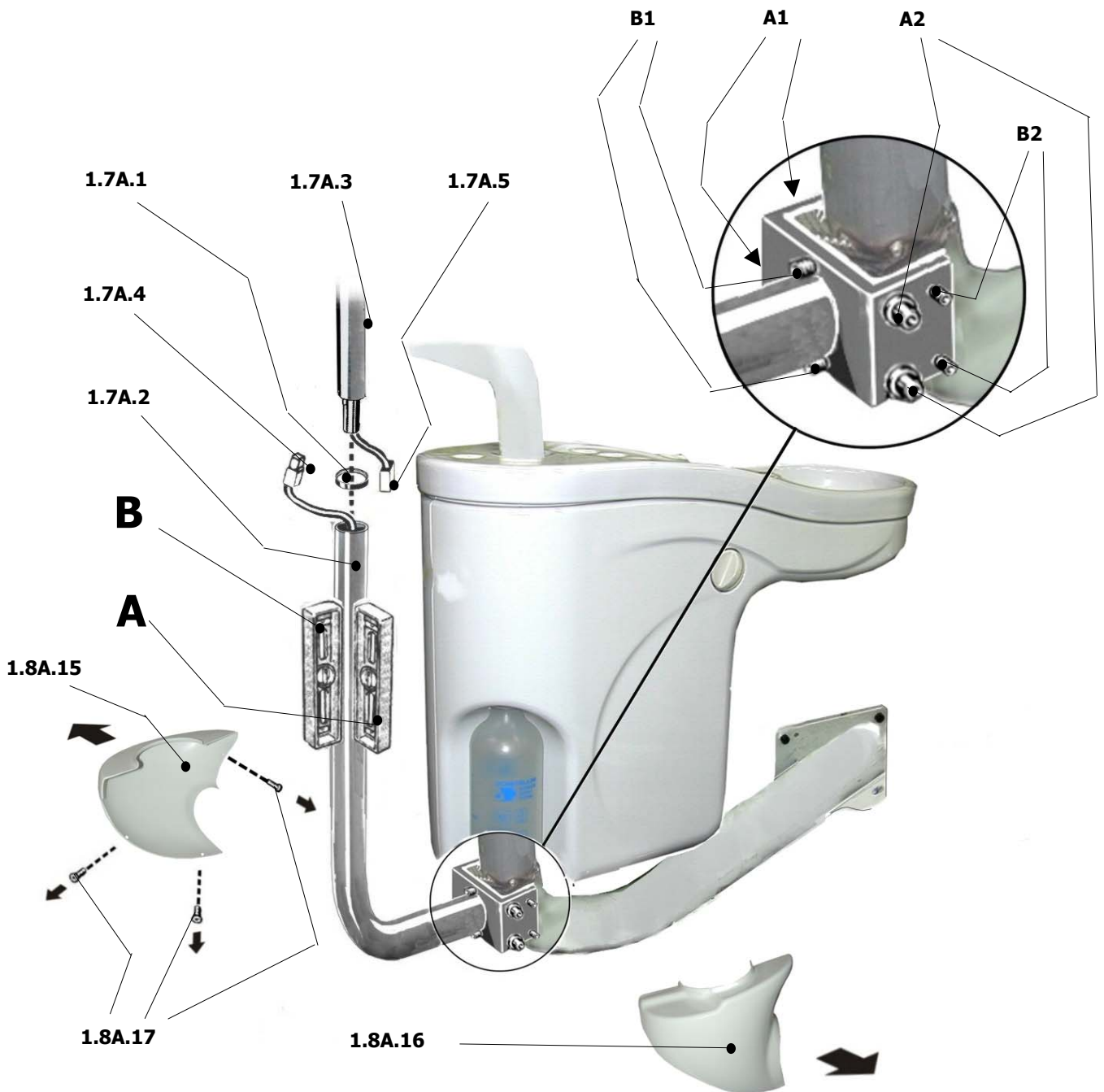

Pict. 1.7B – Installing the scalytic lamp post (model for right hand dental unit)

INSTALLING THE SCIALYTIC LAMP POST AND LEVELLING
(model for right-hand dental unit) (Pict. 1.7B)

- Before starting installation, remove the two side half-covers (**1.8A.15** and **1.8A.16** – Pict. 1.7B) of the supporting arm.
- After fitting the finishing ring (**1.7A.1**) on the lamp post (**1.7A.2**), connect the two connectors of the power cables (**1.7A.4** and **1.7A.5**) and insert the pin of the lamp post (**1.7A.3**) into the arm (**1.7A.2**).
 - After levelling the dental unit, check whether the scalytic lamp is properly levelled by carrying out the steps described in the previous page for left+right handed dental units.

SAFETY COVERS

COVER FOR CHAIR CIRCUITS, FOR SUPPLY BOX AND SAFETY PEDESTAL (Pict. 1.8)

The Castellini Company strongly recommend that cover (1.8.1), which prevents access to parts connected to the electrical mains, be removed with the following procedure only by qualified persons trained and authorized by Castellini:

- Take the chair to a height just below the maximum and switch off the electricity supply;
- Remove the screws (1.8.2);
- Grasp the cover (1.8.1), slide it forward and lift, unhooking it from the two anchoring pins (1.8.3).



Attention: the power terminal board and main switch contacts are always live! After cover (1.8.1) has been replaced, the three securing screws (1.8.2) must be tightened.

The plastic cover (1.8.4) protect the contact with the up/down mechanical device of the chair; to dismount it, it's necessary to slide it upward, pulling and disconnecting it from its seat.

The plastic cover of the security base (1.8.5) is necessary for protect the chair security anticrushing device; to dismount it it's necessary unscrew the two fixing screw (1.8.6) and pull it

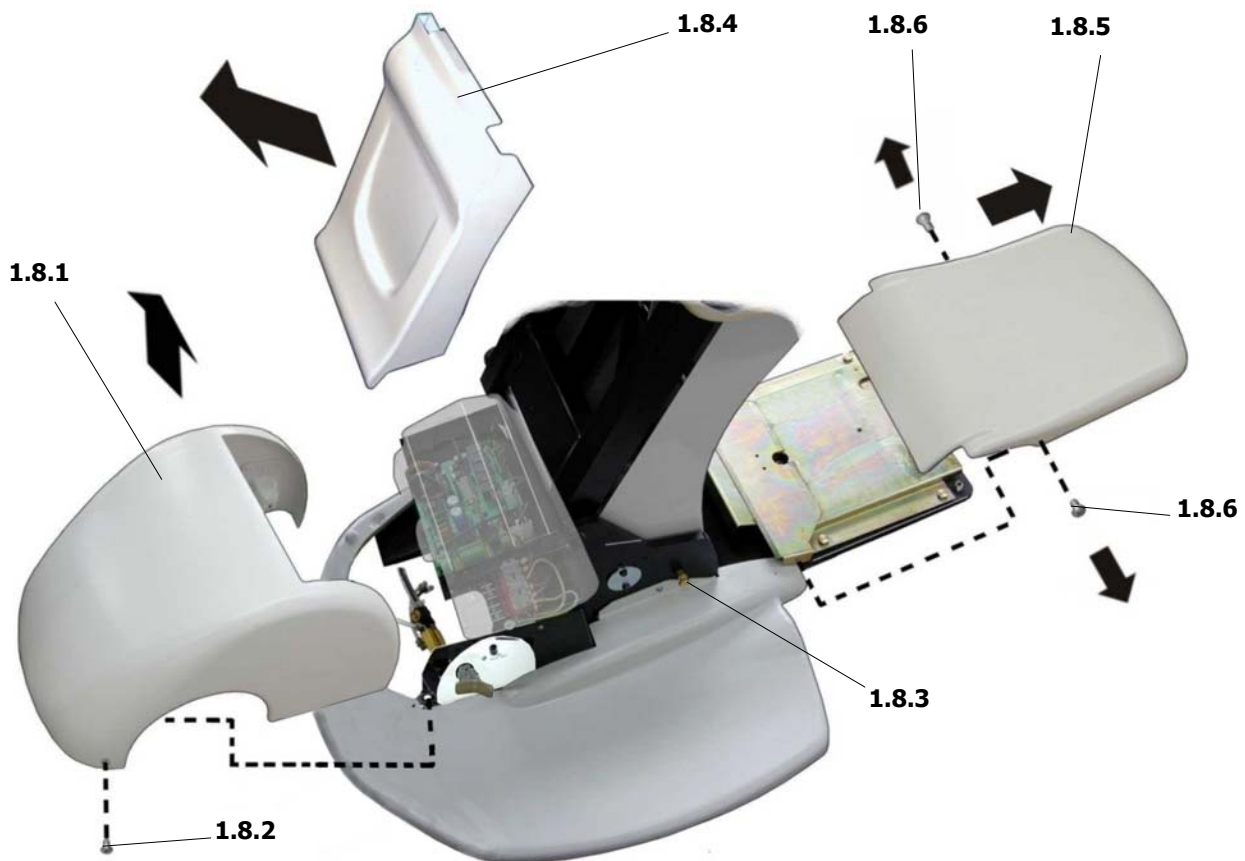

Pict. 1.8 – Safety covers for chair base

HYDRAULIC GROUP SAFETY COVERS (Picts. 1.8A)

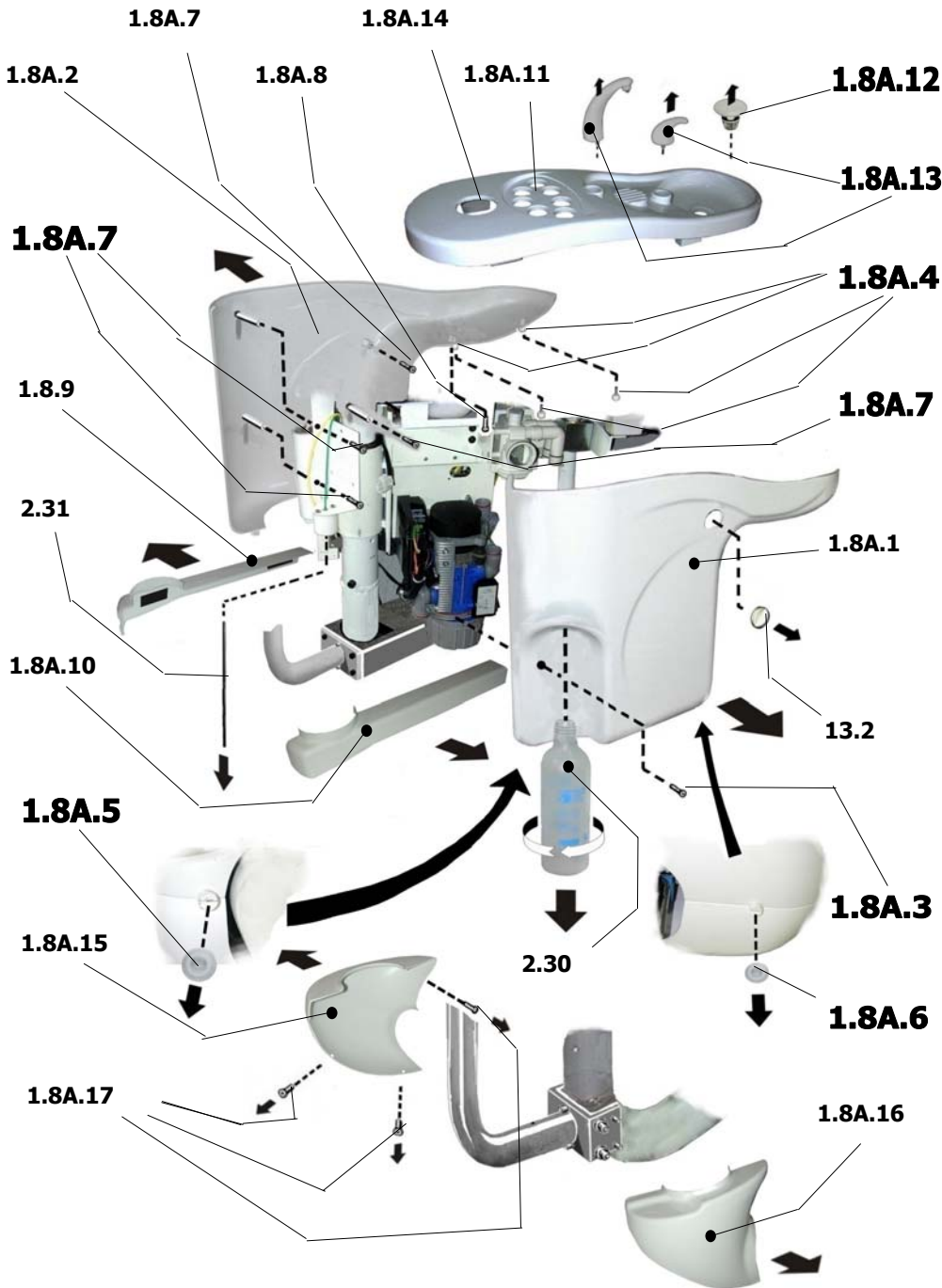

Pict. 1.8A – Hydraulic group safety covers

Before accessing the general electrical switching panel for the secondary low voltage circuits and their corresponding fuses, it is essential to switch the main switch on the unit to the off position.

Then remove the cover (1.8A.1 – Pict. 1.8A) by carrying out the following steps.

- remove the intake filter cap (13.2);
- unscrew and detach the separate supply reservoir and intake needle (2.30 and 2.31);
- take out the screw (1.8A.3) and loosen the two fastening knobs (1.8A.4) situated beneath the cuspidor zone, without removing them;
- finally, remove the two sealing caps (1.8A.5 and 1.8A.6) and take off the side cover.

To remove the inner side cover (1.8A.2) as well:

- remove the four fastening screws, (1.8A.7) screw (1.8A.8) and two knobs (1.8A.4) and take off the cover.

To remove the two side half-covers (1.8A.9 and 1.8A.10) of the rotation arm of the dental unit (left+right handed version only), just pull them outwards firmly to detach the four Velcro inserts.

To remove the two side half-covers (1.8A.15 and 1.8A.16) of the fixed arm of the dental unit (right-handed version only), just take out the 3 screws (1.8A.17).

To access the zone beneath the ceramic cuspidor (1.8A.11), remove the filter (1.8A.12), detach the cuspidor water spout and cup filler terminals (1.8A.13), carefully raise the ceramic part and slide it along the arm of the dentist's instrument tray (1.8A.14) through the hole (1.8A.14).

FITTING CHAIR UPHOLSTERY (Pict 1.9A and 1.9B)

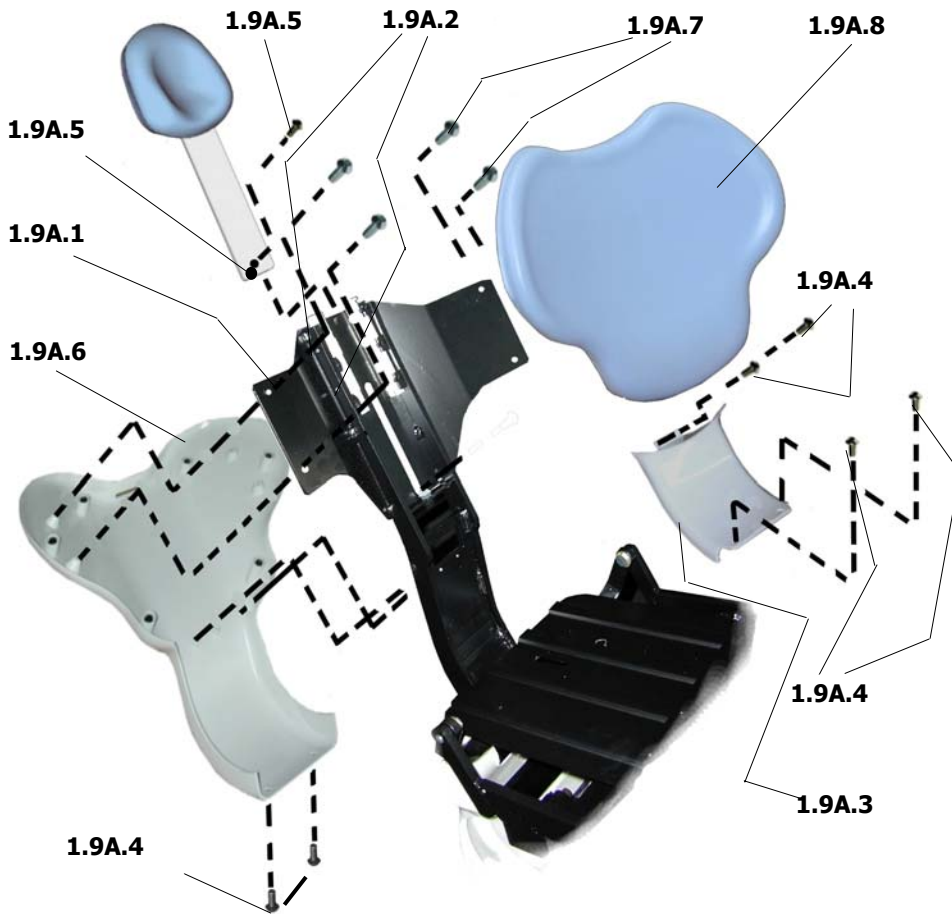

Pict. 1.9A – Fitting chair seatrest upholstery

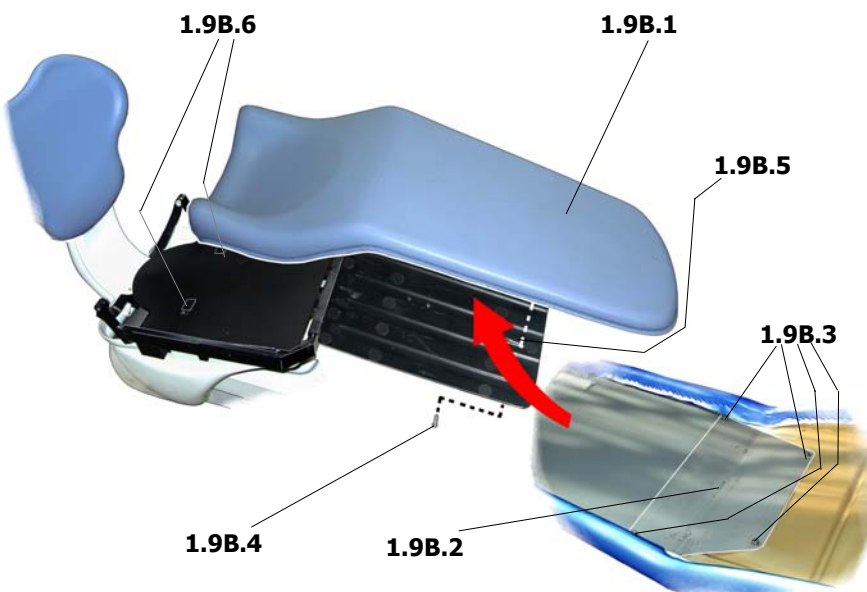

Pict. 1.9B – Fitting backrest and headrest upholstery

The chair is packed with the seat upholstery removed to prevent the risk of damage during transport. To fit the upholstery, carry out the following steps (Pict. 1.9A e 1.9B):

- Fit the rear backrest cover (1.9A.6) using the four screws (1.9A.7) and 2 screws (1.9A.4) provided.
- Fit the front backrest cover (1.9A.3) using the four screws (1.9A.4) provided.
- Insert the headrest, removing the screw (1.9A.5); if necessary, adjust the 2 screws (1.9A.2) so that the rod slides more or less freely; replace the screw (1.9A.5) to prevent the headrest from being pulled out too far.
- Fit the backrest upholstery (1.9A.8) in place, starting from the middle fasteners, and then proceeding to the lower and upper fasteners.
- **Position the chair seat and backrest at the maximum height**
- Overturn upholstery (1.9B.1), remove the 4 screws (1.9B.3) and take off the metal supporting frame (1.9B.2).
- Apply the fastening screw (1.9B.4) on the bottom of the front part of the seat upholstery (1.9B.1) leaving it loose.
- Position the upholstery on the metal frame, passing the head of the screw through the front (widest) part of the slot (1.9B.5)
- Place the seat upholstery on the metal supporting frame and adjust it so that it fits correctly on the rear part. Then press to cause it to adhere to the two velcro inserts (1.9B.6).

N. B.: while carrying out the above steps **always try to keep the seat upholstery in a horizontal position** to avoid creating permanent creases and other surface imperfections.

REPLACING THE LAMP OF THE NEGATOSCOPE FOR INTRAORAL X-RAYS (Pict. 1.10)

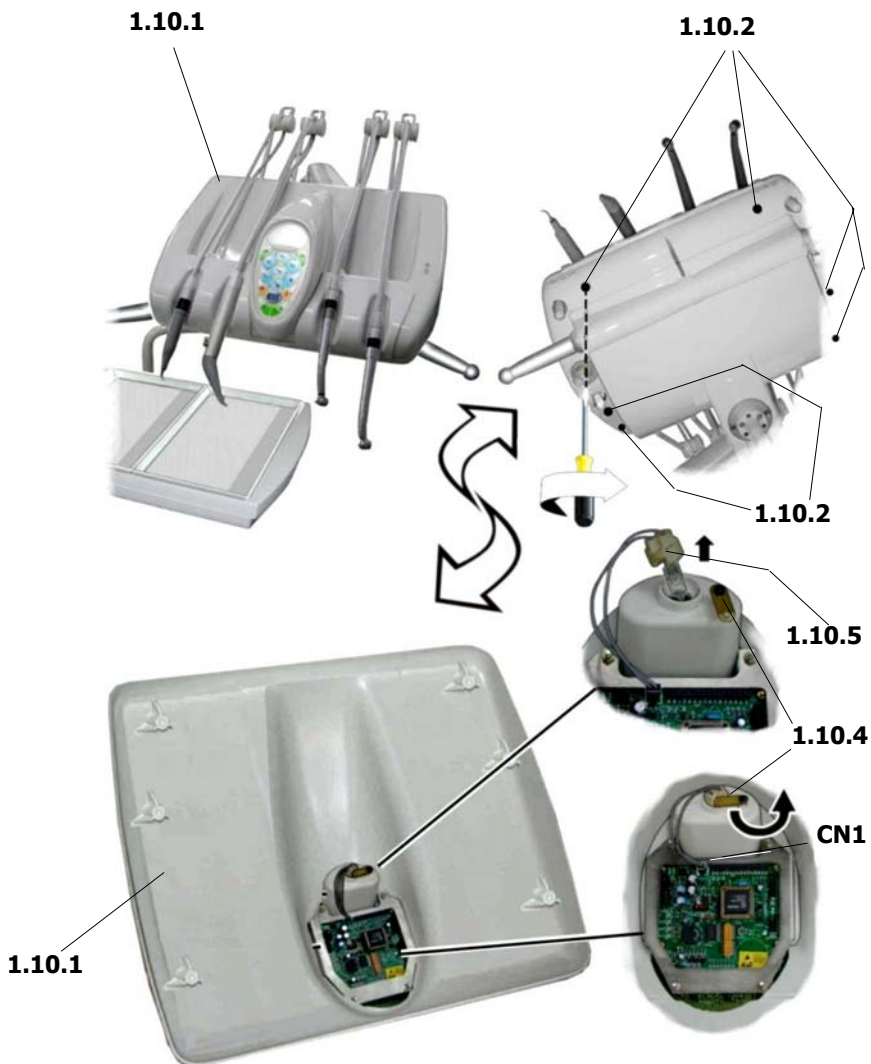

This lamp replacement operation may be carried out solely by technical personnel authorised by Castellini, according to the following instructions:

- switch off the dental unit and remove the instruments from their holders in the instrument tray;
- unscrew the 6 fastening screws (1.10.2) situated on the front of the instrument tray cover (1.10.1);
- lift the rear part (1.10.1) of the instrument tray cover and then lift and turn it 180° to make the job easier;
- turn the locking lever of the lamp holder (1.10.4) as shown in the picture and then remove the lamp holder and lamp;
- replace the lamp (1.10.5), after removing it from the holder. **Use only original replacement lamps supplied by the manufacturer**, making sure that the power indicated on the lamp (5 W) corresponds to the rating shown on the negatoscope.

N.B.: Do not touch the bulb with bare hands, in the event of accidental contact cleanse using alcohol.

Pict. 1.10 – Replacing the negatoscope lamp for intraoral x-rays

ADJUSTING THE TENSION OF THE LEVERS ON THE INSTRUMENT TRAY
MODEL S.P.R.I (Pict. 1.11)

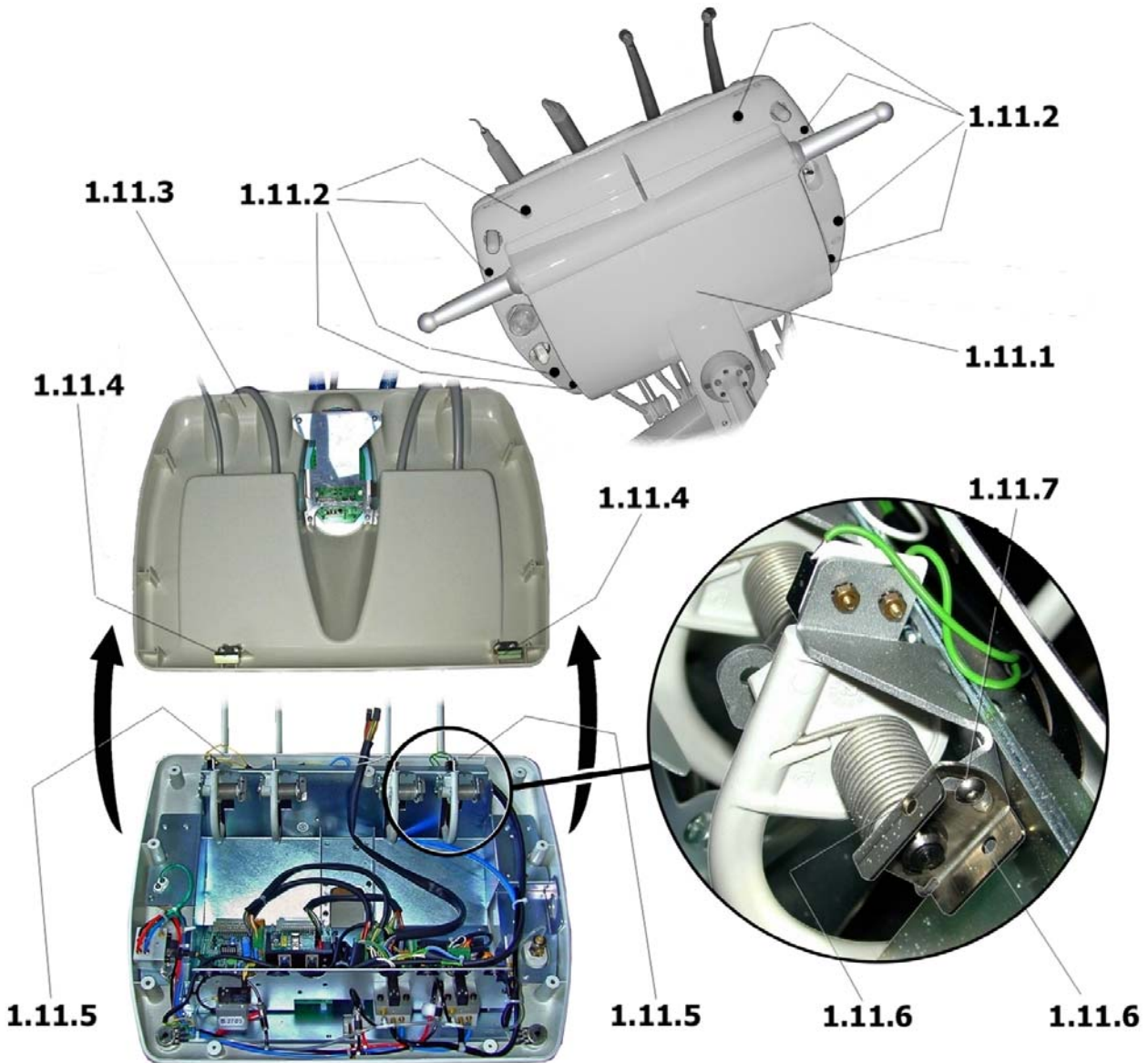

Pict. 1.11 – Adjusting the tension of the levers on the instrument tray

The return movement of the levers on the S.P.R.I. instrument tray is adjusted by the Manufacturer prior to dispatch of the dental unit.

Should further adjustment be required, carry out the following steps:

- Remove the upper part of the tray as shown in pict. 1.10
- With the levers in the rest position, insert the tip of a screwdriver or another pointed tool through the two holes (1.11.6) of the lever-return spring adjustment plate. After loosening the retaining screw (1.11.7), turn the plate clockwise or anticlockwise to decrease or increase, respectively, the return force of the hose levers. Then tighten the retaining screw and close the instrument tray.

1.12.1

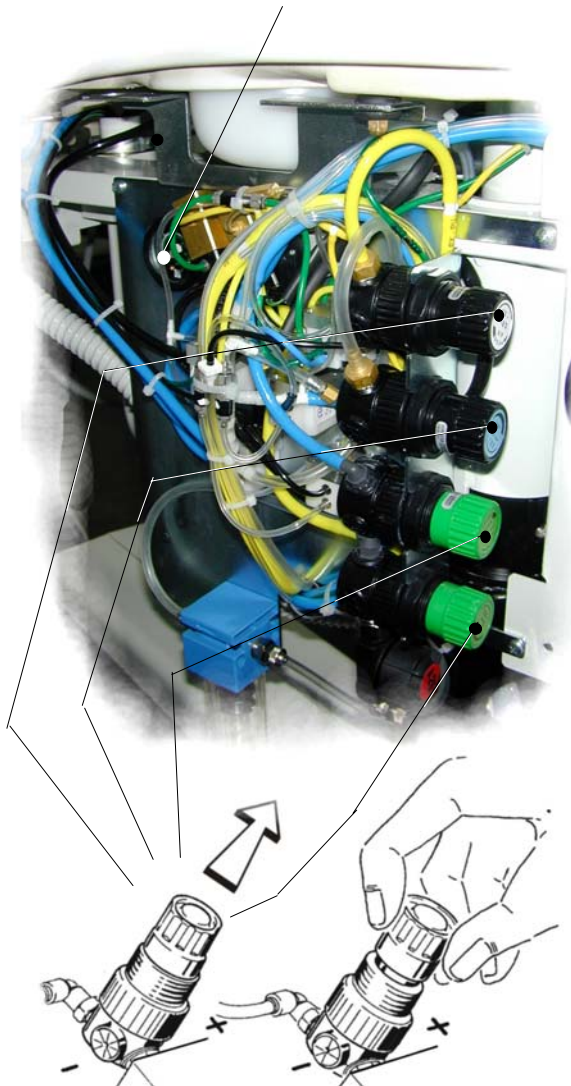

Pict. 1.12 – Adjusting the working pressures

ADJUSTING THE WORKING PRESSURES (Pict.1.12)

The air and water pressures have been factory-set to ensure the proper operation of the dental unit.

The manufacturer is not responsible for faulty operation that may result from any tampering with these settings.

All future adjustments of the pressure regulators must be done as follows only by qualified personnel authorized by the Castellini Company:

- Pull the knob outwards to unlock the regulator. Then turn it clockwise to increase the pressure, or counterclockwise to reduce the pressure.
- After the pressure has been adjusted, lock the pressure regulator by pressing the knob in.

PRESSURE SETTINGS

| | |
|---|-------------------------------|
| Drinking water - syringe - instrument spray water | 90÷140 kPa (0,9÷1,4 bar); |
| Air for turbine and air micromotor | 260÷280 kPa (2,6÷2,8 bar): |

(measured with the appropriate pressure gauge placed between the connector and the turbine, Code N. L0001067).

N.W.: For a correct pneumatic feeding of the unit, the manometer (1.12.1) placed on the general panel inside the unit body must show: 430÷470 kPa (4,3÷4,7 bar).

"Puma Evo" Unit (ambidextrous version) + "DAMA" motor chair

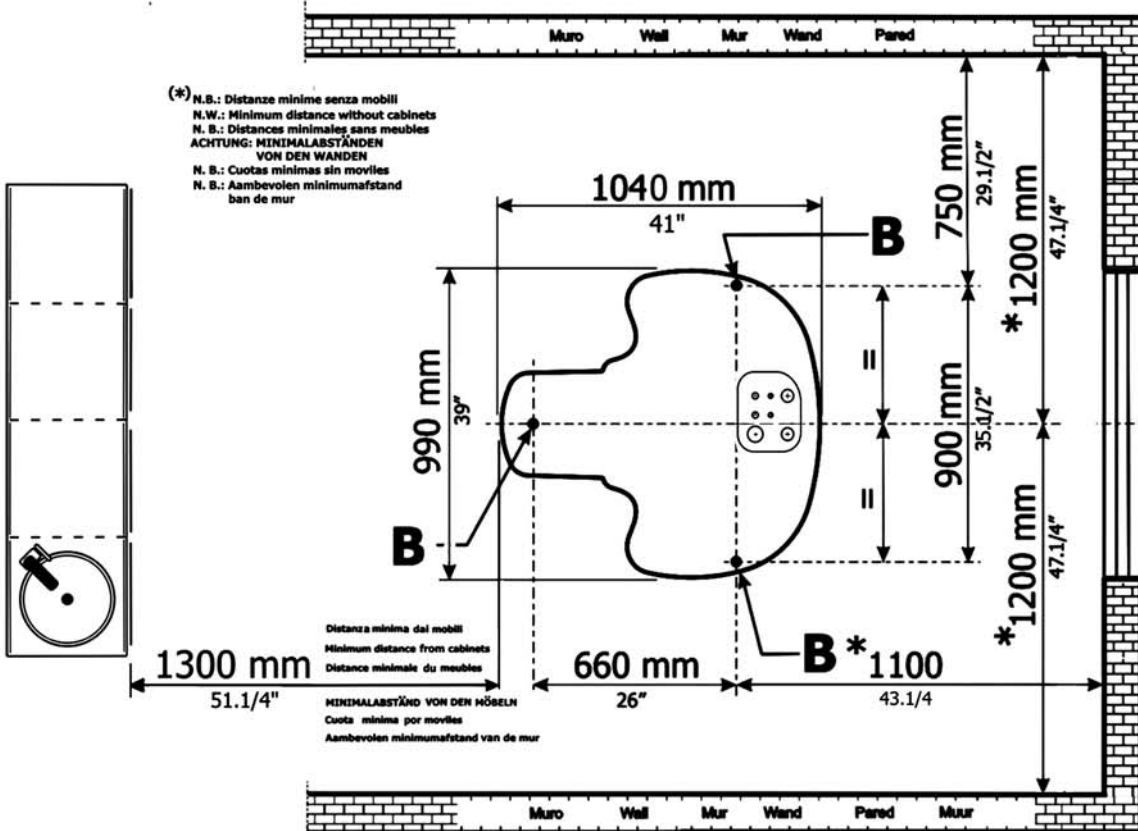
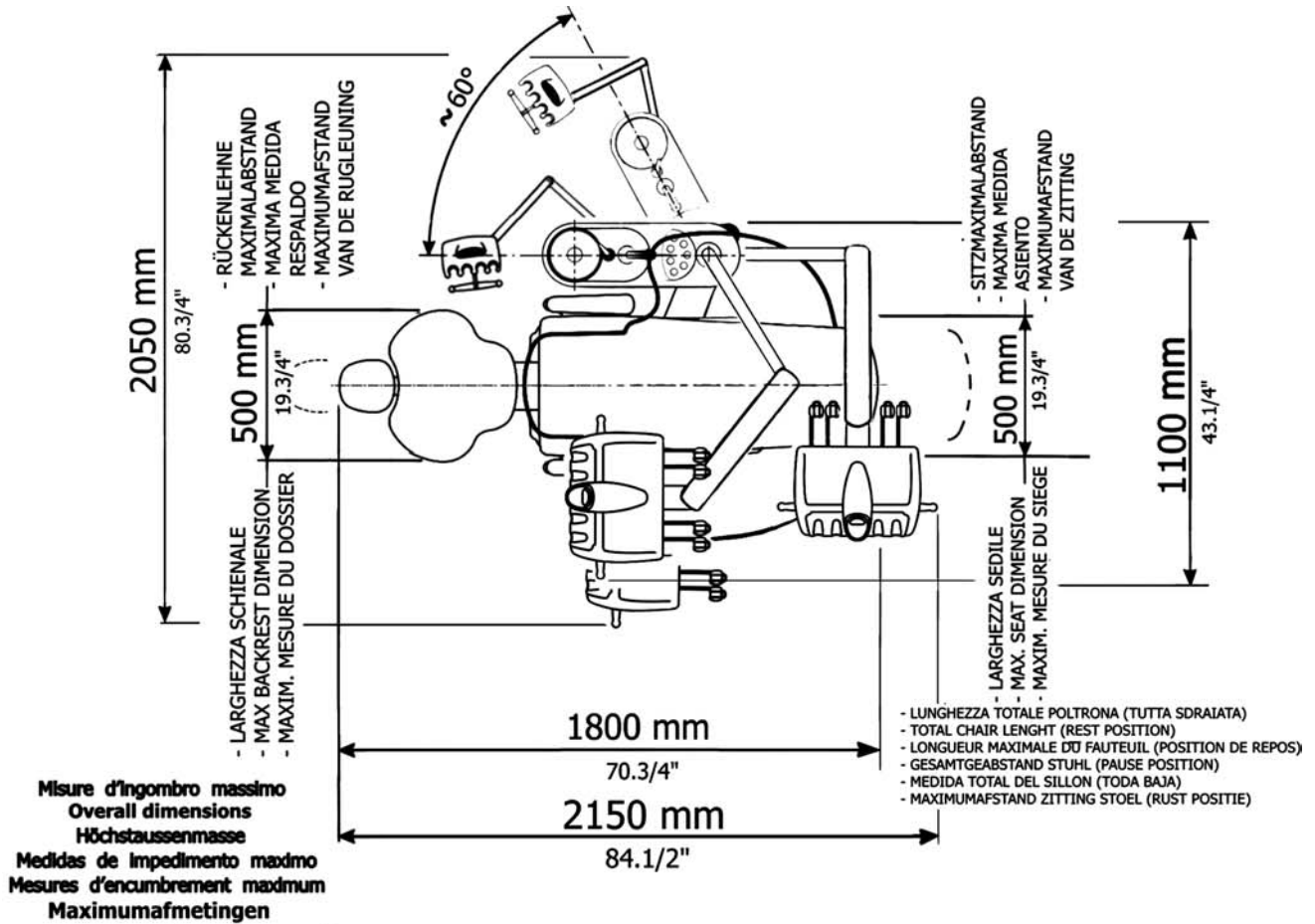

"Puma Evo" unit (right-hand version) + "DAMA" motor chair

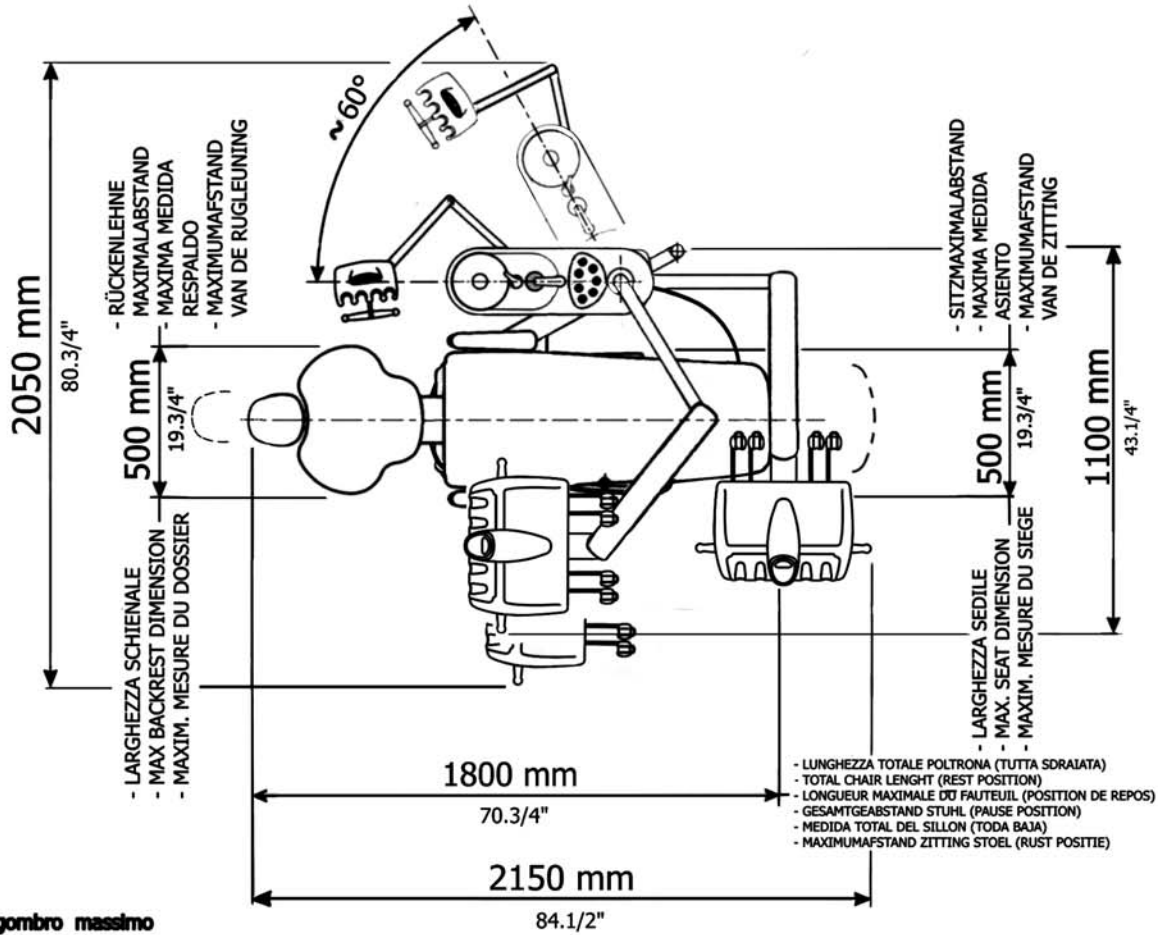

Misure d'ingombro massimo
Overall dimensions
Höchstaussenmasse
Medidas de impedimento máximo
Mesures d'encubrement maximum
Maximumafmetingen

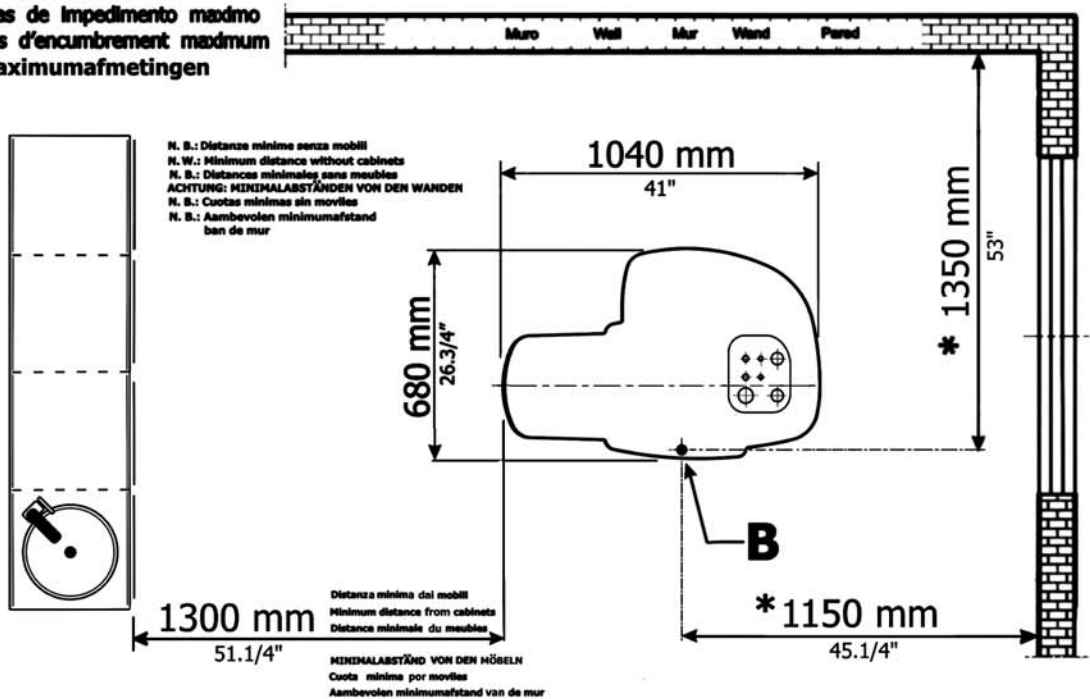

"Puma Eli Cart" Unit + "DAMA" motor chair

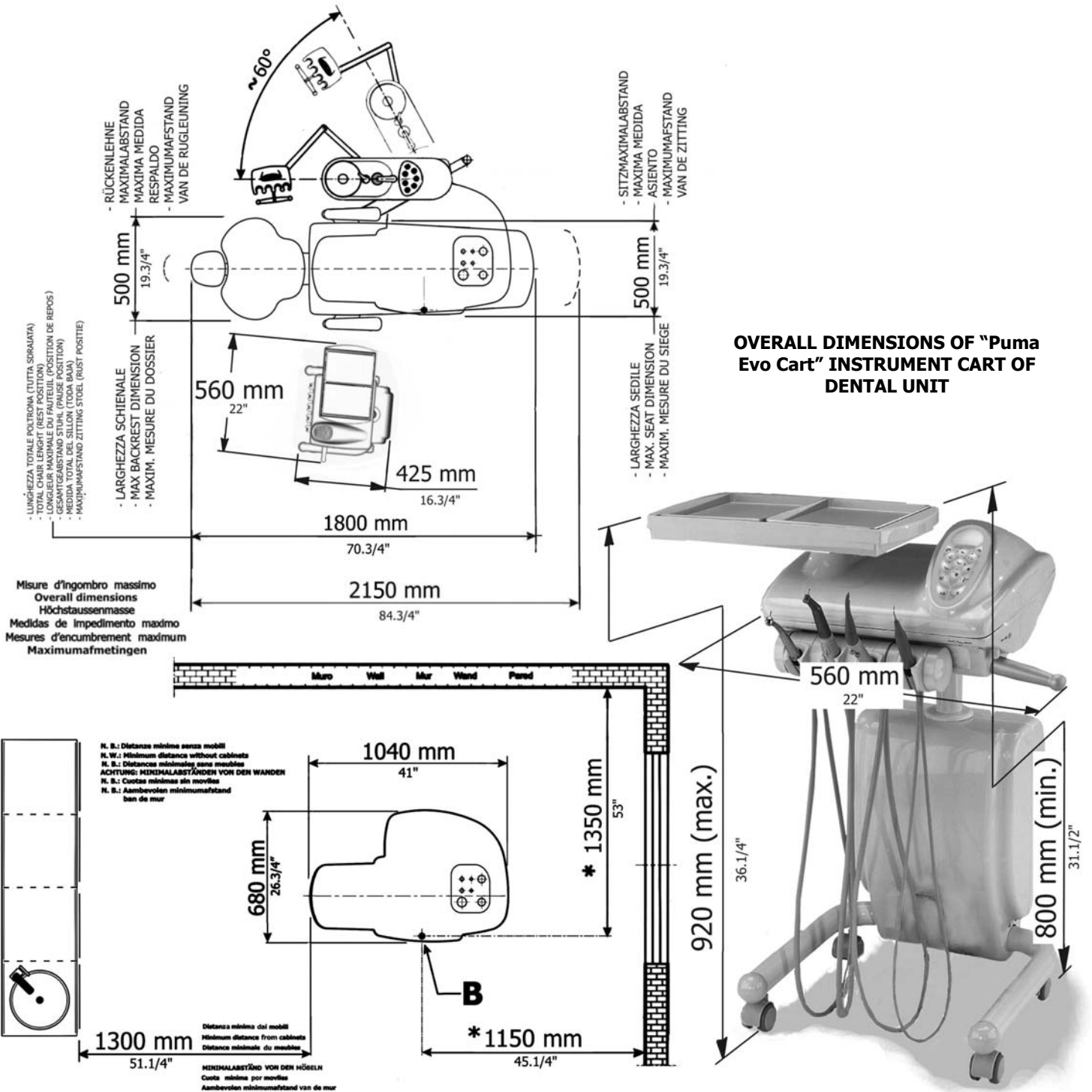

UNIT HYDRAULIC SYSTEMS

DENTIST'S TABLE (CODE 390U0100)

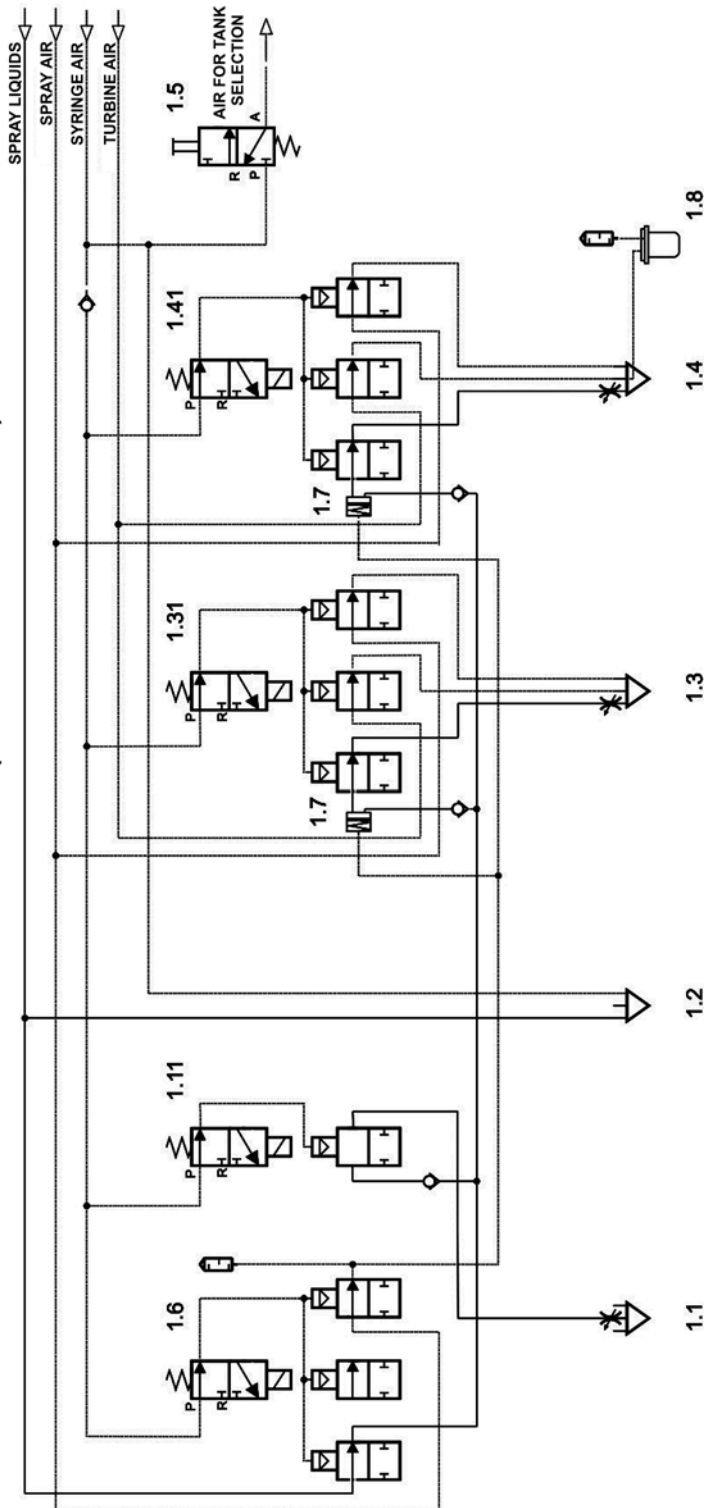

**DENTIST'S TABLE
(CODE 390U0100)**

- 1.1** – Scaler handpiece.
- 1.2** – Syringe.
- 1.3** – Micromotor.
- 1.4** – Turbine.
- 1.5** – Selector for water supply/liquids tank.
- 1.6** – Solenoid valve for backdraw valve air and spray liquids.
- 1.7** – Valve for spray re-aspiration.
- 1.8** – Tank for turbines oil
- 1.11** – Solenoid valves for scaler selection.
- 1.31** – Solenoid valves for micromotor selection
- 1.41** – Solenoid valve for turbine selection.

HYDRAULIC GROUP (CODE 390U0200)

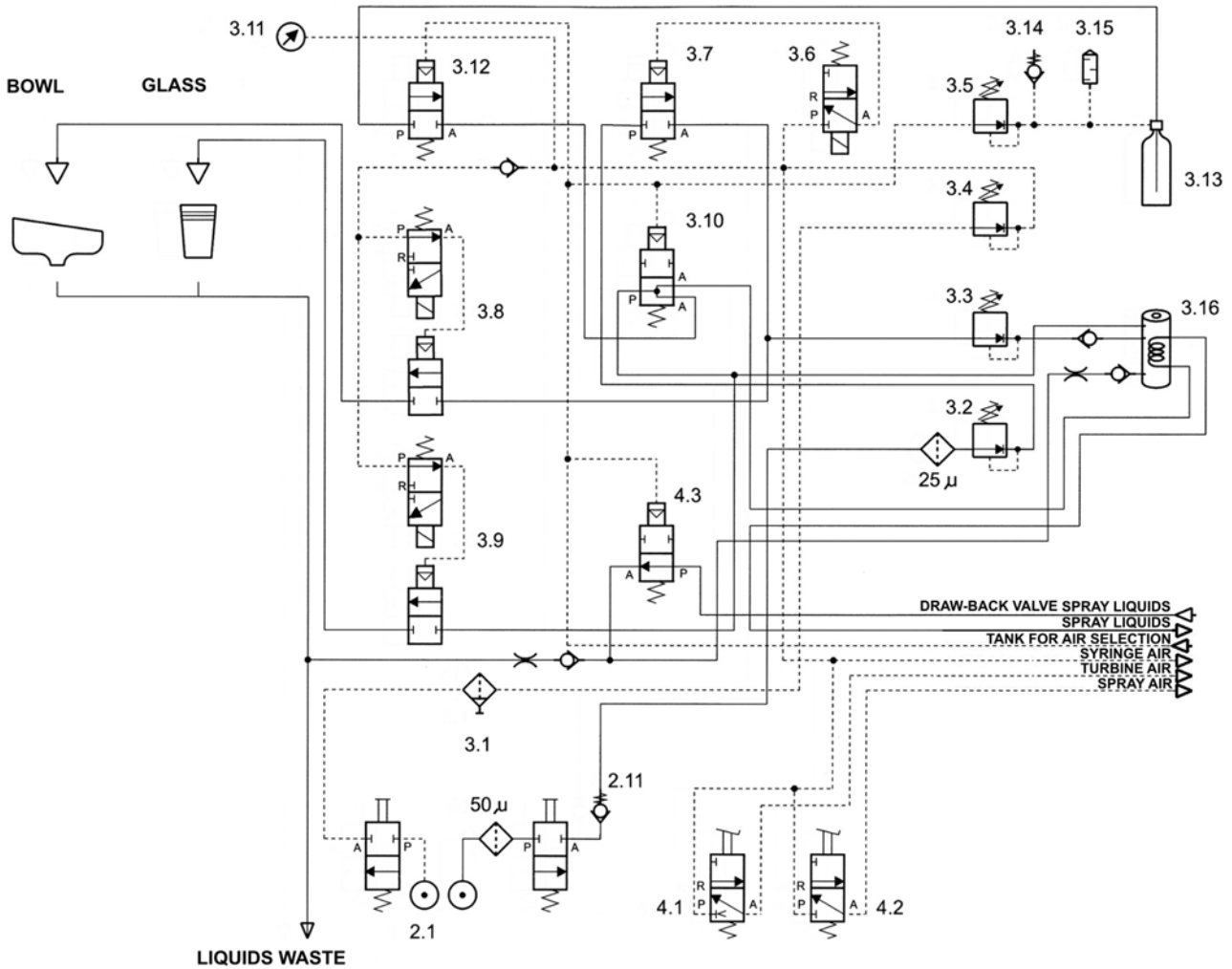

HYDRAULIC GROUP (CODE 390U0200)

- 2.1** – Main switch for air and water.
- 2.11** – Not-return valve for water.
- 3.1** – Main air filter.
- 3.2** – Pressure reducer for water to the bowl.
- 3.3** – Pressure reducer for water to glass and spray.
- 3.4** – Pressure reducer for air.
- 3.5** – Pressure reducer for spray liquids tank.
- 3.6** – Solenoid valve for water cut-off valve.
- 3.7** – Water cut-off valve.
- 3.8** – Solenoid valve for water to the bowl.
- 3.9** – Solenoid valve for water to the glass.
- 3.10** – Selection valve for spray liquid.
- 3.11** – Manometer.
- 3.12** – Valve spray liquids tank cup.
- 3.13** – Dedicated liquids tank cup.
- 3.14** – Security valve for dedicated liquids tank cup.
- 3.15** – Calibrated waste for vacuum dedicated liquids tank cup.
- 3.16** – Water heater for glass and spray liquids.
- 4.1** – Valve for turbine power and micromotor cooling.
- 4.2** – Spray air valve for chip-air to the turbine and micromotor.
- 4.3** – TAD system solenoid valve (*only Puma Evo*)

UNIT ELECTRIC SYSTEMS

**MOTOR CHAIR - HYDRAULIC GROUP
ASSISTANT TABLE - FOOT CONTROL
(CODE 390T0100)**

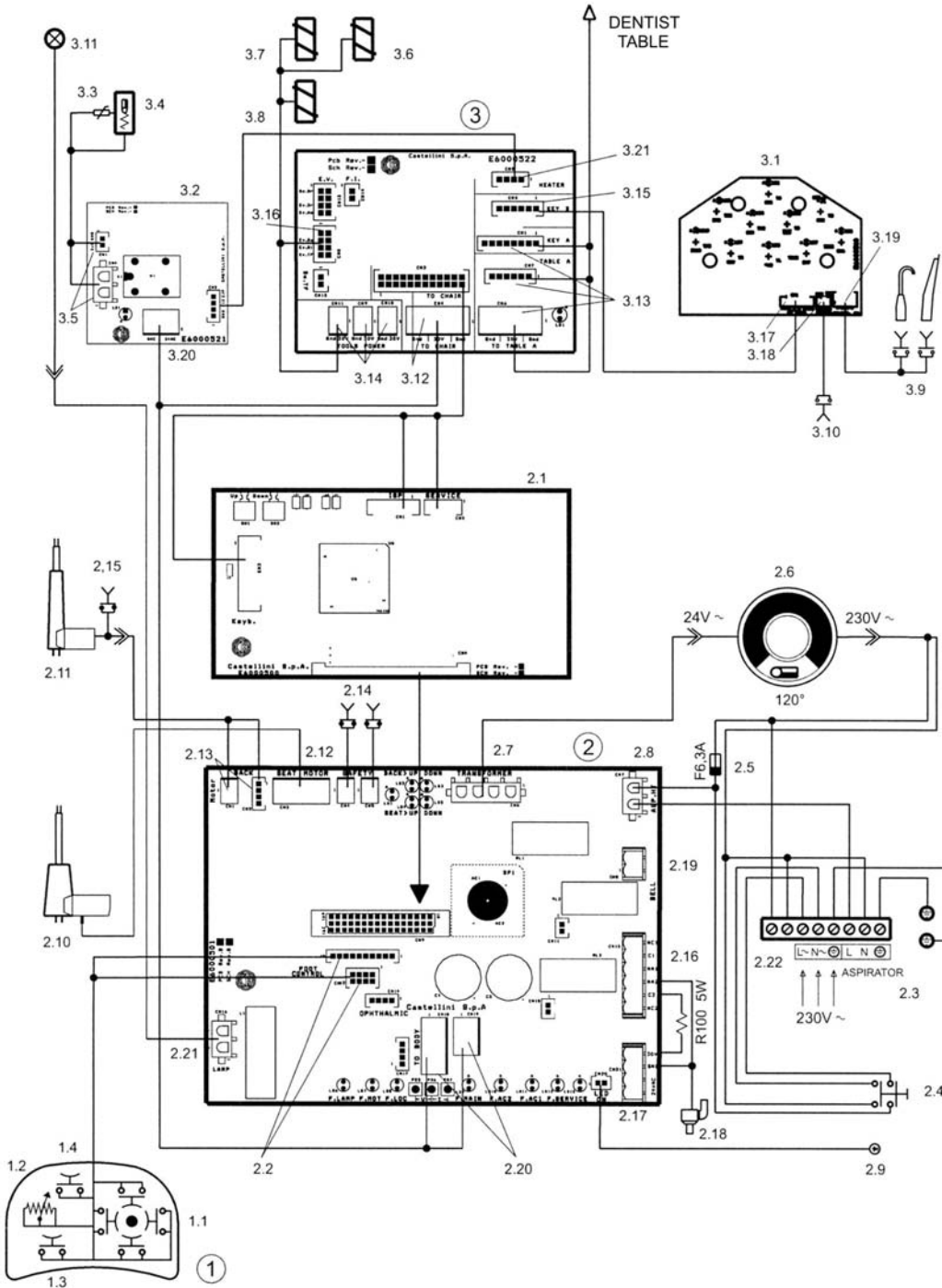

CHAIR – HYDRAULIC GROUP – ASSISTANT TABLE – FOOT CONTROL (CODE 390T0100)

- 1** – Foot control.
- 1.1** - Chair controls.
- 1.2** - Potentiometer regulation for micromotor speed control.
- 1.3** - Microswitch for handpieces activation.
- 1.4** - Microswitch for spray insertion.
- 2** - Circuit for motor chair and dental unit power E6000501.
- 2.1** - Motor chair Controller circuit E6000500.
- 2.2** - Connectors for foot control cable connections.
- 2.3** - Connection board for electric connection and aspiration motor connection.
- 2.4** - Main switch.
- 2.5** - F 6,3A rapid fuse for primary transformer.
- 2.6** - Transformer 230/24V 50/50Hz 400VA.
- 2.7** - Connector for 24V transformer connection.
- 2.8** - Connector for aspirator motor lighting.
- 2.9** - Main pilot light.
- 2.10** - Up and down chair motor.
- 2.11** - Backrest and return chair motor.
- 2.12** - Connector for power and up and down chair motor control.
- 2.13** - Connectors for power and backrest and return chair motor control.
- 2.14** - Microswitches for anti-crush safety device.
- 2.15** - Backrest safety microswitch.
- 2.16** - Connection board for activation and aspiration power.
- 2.17** - Connection board for 32 VDC and 24 VAC for services.
- 2.18** - Aspiration pneumatic valve.
- 2.19** - Clipboard for assistant call.
- 2.20** - Connectors for power and unit control.
- 2.21** - Connectors for scalytic lamp electric feeding.
- 2.22** - Videocam external feeding.
- 3** - Hydraulic group power circuit E6000522.
- 3.1** - Assistant table power and control panel circuit.

- 3.2** – E6000521 Feeding and heater tank control circuit
- 3.3** – NTC liquids heater temperature control.
- 3.4** – Heater for water to glass, spray liquids and syringe.
- 3.5** - Feeding and heater control connectors.
- 3.6** – NC Solenoid valve for liquids blocking air.
- 3.7** – Solenoid valve for water to the bowl.
- 3.8** - Solenoid valve for water to the glass.
- 3.9** - Microswitch for assistant's table tips selection.
- 3.10** – Microswitch for handle security device for assistant's table.
- 3.11** – Operating lamp.
- 3.12** - Connectors for feeding and unit control from the motor chair.
- 3.13** - Connectors for feeding and unit control dentist's table.
- 3.14** - 32 VDC feeding connectors.
- 3.15** - Connectors for feeding and control assistant's table.
- 3.16** – Connector for glass and bowl solenoid valve feeding.
- 3.15** - Connectors for feeding and assistant's table control circuit.
- 3.18** – Connectors for microswitch for handle security device for assistant's table.
- 3.19** - Connector for assistant's table microswitch selection.
- 3.20** - Connectors for heater tank circuit feeding (24 VAC).
- 3.21** - Connector for heater control circuit.

DENTIST'S TABLE (CODE 390T0200)

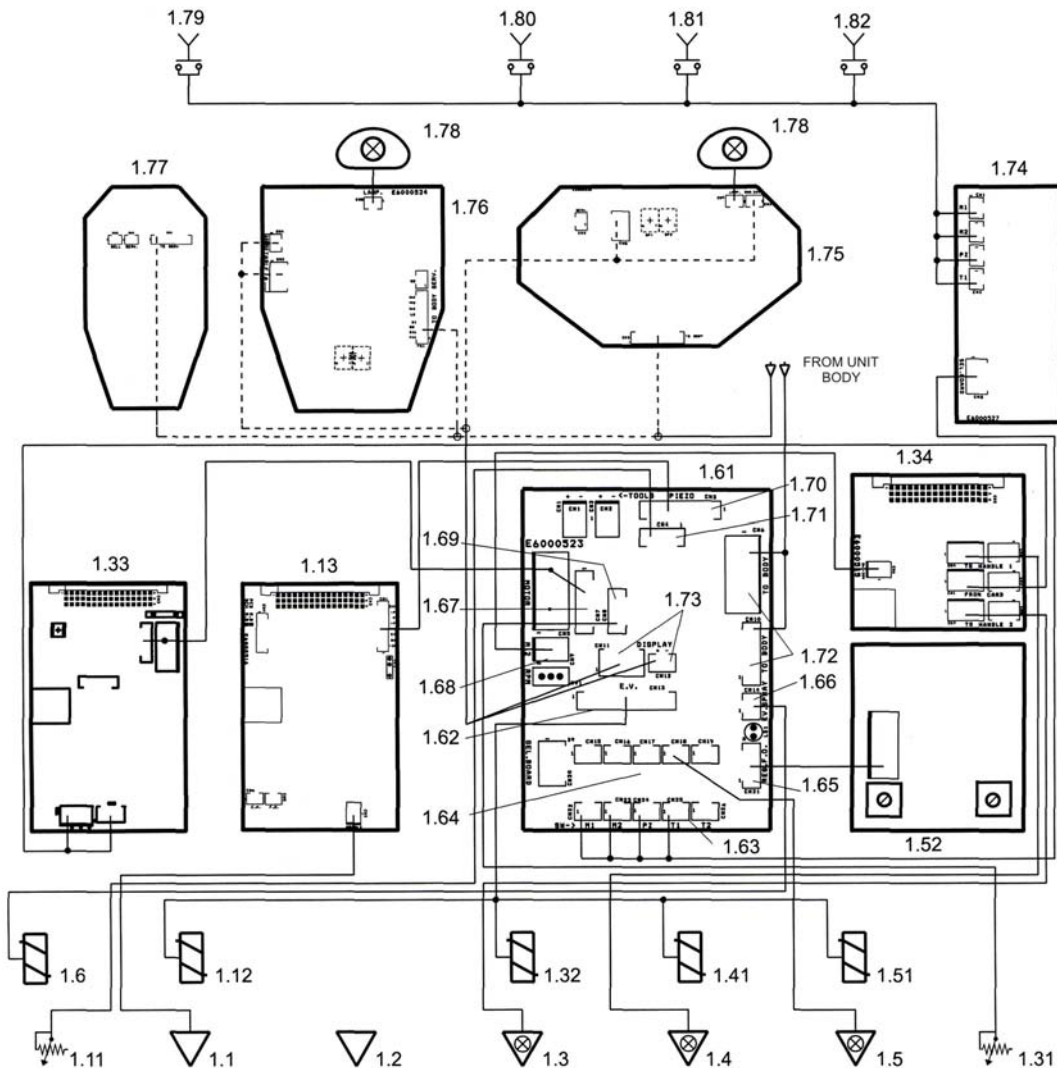

DENTIST'S TABLE (CODE 390T0200)

- 1.69** - Connector for ablator potentiometer.
- 1.70** - Connector for ablator potentiometer circuit.
- 1.71** - Connector for ablator potentiometer.
- 1.72** - Connector for feeding and control of handpiece table from unit.
- 1.73** - Control board connectors.
- 1.74** - Connectors for handpieces double-operativity .
- 1.75** - PUMA EVO 5 control circuit.

- 1.1** - Ablator handpiece.
- 1.2** - Syringe.
- 1.3** - Micromotor O.F.
- 1.4** - Additional O.F. micromotor (only if required).
- 1.5** - Turbine O.F.
- 1.11** - Potentiometer for power regulation ablator handpiece.
- 1.12** - Solenoid valve for ablatore.
- 1.13** - Ablator handpiece feeder circuit.
- 1.31** - Potentiometer for speed micromotor regulation.
- 1.32** - Solenoid valve for micromotor selection.
- 1.33** - Micromotor feeding circuit.
- 1.34** - 2nd micromotor selection circuit.
- 1.41** - 2nd micromotor solenoid valve selection.
- 1.51** - 2nd micromotor solenoid valve selection.
- 1.52** - O.F. feeding circuit.
- 1.6** - Spray solenoid valve.
- 1.61** - Dentist's table circuit.
- 1.62** - Connector for handpieces valve selection.
- 1.63** - Connector for handpieces microswitch.
- 1.64** - Connector for O.F. handpieces cords feeding
- 1.65** - Connector for O.F. circuit feeding.
- 1.66** - Connector for spray S.V. feeding.
- 1.67** - Connector for micromotor circuit feeding.
- 1.68** - Connector for 2nd micromotor selection circuit.



Puma Evo

***PART V* – SCHEDULED MAINTENANCE PROGRAM, SERVICING AND WARRANTY CONDITIONS**

SCHEDULED MAINTENANCE AND SERVICING

INTRODUCTION

In accordance with Directive 93/42 EEC, Appendix 1 Item 13.6 par. D, the periodic maintenance program contains *"complete information regarding the nature and frequency of the operations necessary to constantly ensure the efficiency and safety of this equipment"*.

The Manufacturer notes that all scheduled maintenance and/or servicing of this equipment MAY ONLY be performed by specialised personnel in possession of a regular, currently valid "Castellini Authorised Technician" license (See Part "Important Information" and Part "Essential Rules").

As provided by Directive 93/42 EEC, implemented in Italy through Law Decree n° 46 of 24 January 1997 and Law Decree n° 95 of 25 February 1998, Castellini S.p.A, guarantees that the safety, reliability and performance requisites certified by the EC mark will be maintained only if maintenance and/or servicing is performed by persons who are specially trained, authorised and updated by Castellini itself and in possession of a regular, currently valid "Castellini Authorised Technician" license.

Any maintenance and/or servicing performed by persons other than those authorised will be considered improper use in contradiction with the manufacturer's directions and will as a result compromise the essential safety requisites prescribed by Directive 93/42 EEC, thereby invalidating the EC mark placed on the device. The warranty will likewise become null and void (see item A, letter 2 of the Warranty Conditions), and the manufacturer will be exempted from all the liabilities provided under President's Decree 224/88 and/or applicable European Directives.

In light of the above considerations, if maintenance and/or servicing is entrusted to persons not in possession of a valid "Castellini Authorised Technician" license, the safety of this device WILL NOT BE GUARANTEED BY THE EC MARK and the user will be working with a product that does not comply with current regulations, according to the requisites stated by Legislative Decree 626/94 and/or applicable European Directives.

SCHEDULED PERIODIC MAINTENANCE

The Manufacturer notes that scheduled periodic maintenance MUST BE performed according to the terms and procedures indicated below, in order to preserve the validity of all the certifications pertaining to the device and the manufacturer's liability in regard to the EC mark on the product itself.

Periodic maintenance operations must be performed at the time intervals indicated in the periodic check forms provided below.

The owner of the device is always responsible for calling in the technician, who must meet the requisites described above; The Technician who performs scheduled maintenance will ensure that the periodic check forms provided are duly and accurately compiled and, on his own responsibility, he will sign and stamp them;

The periodic check forms are in two copies; one must remain attached to this manual as proof that the periodic check has been carried out;

The owner of the device is responsible for keeping all the technical documents regarding maintenance work and the periodic check forms, which must be shown to inspectors on request.

For each scheduled maintenance operation the user will be charged hourly labour costs, a flat-rate calling cost and the cost of replacing any worn parts, according to the existing contract conditions, unless otherwise indicated on the periodic check forms themselves.

Should any faults be revealed during the scheduled maintenance checks, the technician will either service the equipment or replace any worn parts.

N.B.: IN THE PERIODIC CHECK FORMS THE MANUFACTURER PRESCRIBES A COMPULSORY GENERAL OVERHAUL OF TURBODRILLS 3 YEARS AFTER THEIR INSTALLATION. FOR THIS PURPOSE THE TURBODRILLS MUST BE SENT TO THE MAIN OFFICE OF CASTELLINI S.P.A. (Via Saliceto, 22, 40013 Castel Maggiore Bologna) AND MUST UNDERGO FURTHER OVERHAULS EVERY THREE YEARS.

DESCRIPTION OF SCHEDULED MAINTENANCE OPERATIONS

All scheduled maintenance must include all the operations specified in the Check List on the back of each periodic check form.

The Check List must be completely filled out and duly stamped and signed by the technician who performs the maintenance.

SERVICING

The manufacturer accepts no liability for guaranteeing the certifications pertaining to the device, compliance with the EC mark requisites or the conformity of this device with current laws, as prescribed by Leg. Decree 626/94 and/or applicable European Directives, if servicing is not carried out in full accordance with the rules provided in this manual (See in particular Part IV, Instructions for installers, ESSENTIAL RULES).

The Manufacturer again emphasises that only persons in possession of a currently valid "Castellini Authorised Technician" license may service the equipment (See above considerations in the Introduction, of this manual). Technical personnel, as specified above, may not connect to Castellini products any other medical devices and/or accessories that are not recommended by Castellini or are in any case outside the parameters of compatibility indicated by Castellini S.p.A. Unauthorised modifications, arbitrary tampering and maintenance work not complying with the directions provided by Castellini are likewise forbidden, as is the use of non-original spare parts and/or components.

Any failure to comply with the above prescriptions will be considered improper use in contradiction with the manufacturer's directions and will as a result compromise the essential safety requisites prescribed by 93/42 EEC Directive, thereby invalidating the EC mark placed on the device. All liabilities will fall on whoever has performed the work without authorisation.

IMPORTANT

Original Castellini spare parts and/or components are exclusively available through the Castellini S.p.A. main office and local Authorised Service Centres.

Whenever servicing is to be carried out, the user is fully entitled to ask the technician to show his license as "Authorised Castellini Technician", which must be identical to the facsimile shown below.

*FRONT**BACK*

| Tecnico Autorizzato Castellini | |
|---------------------------------------|-------|
| Nome | _____ |
| Cognome | _____ |
| data di emissione | _____ |
| data di scadenza | _____ |
| Centro Impiantistico | _____ |

Questo documento è di proprietà della Castellini S.p.A. e deve essere restituito in qualsiasi momento a semplice richiesta. Deve essere esposto nel corso di visite presso la clientela. La sua validità è limitata alla data indicata. Alla scadenza deve essere restituito alla Castellini S.p.A., la quale avrà facoltà di effettuare l'emissione di un nuovo documento. L'uso improprio o la manomissione del presente e comunque l'utilizzo oltre i termini di validità dello stesso, saranno perseguiti a norma di legge. Il furto o lo smarrimento devono essere comunicati alla Castellini S.p.A. nel più breve tempo possibile. Chiunque lo trovi è pregato di inviarlo a:

**CASTELLINI S.p.A. Via Saliceto,22
40013 - Castel Maggiore (BO) - Tel. 051.700877**

*...license as "Authorised Castellini Technician"...***PROTOCOL FOR HYGIENE AND MAINTENANCE OF THE CASTELLINI DENTAL UNIT**

The user is responsible for complying in full with the "protocol for hygiene and maintenance of the dental unit" when carrying out the maintenance operations reserved to the user him/herself and adequately trained assistants.

The "protocol for hygiene and maintenance of the dental unit" represents an integral part of the equipment use and maintenance manual.

The manufacturer recommends posting the "protocol for hygiene and maintenance of the dental unit" on the wall to allow constant and immediate consultation.

WARRANTY CONDITIONS

A) Equipments manufactured by CASTELLINI S.p.A. are covered by warranty for a period of 365 days from the date of installation and therefore will be repaired and/or replaced free of charge any part recognised defective during the warranty period, with the exception of defects caused by fortuitous events, natural wear and tear, and defects due to the fault of the buyer (negligence, inexperience, shocks, falls, accidental knocks).

At the installation date the Warranty Certificate must be returned to Castellini S.p.A. headquarters duly filled, signed and countersigned by the Castellini dealer, otherwise the warranty will be automatically invalidated.

The parts to be repaired or replaced must be sent at customer expenses prepaid to our warehouses. Parts under warranty (with corresponding serial number) will not be sent before the defective part has been received, unless an exception is made exclusively by CASTELLINI S.p.A..

The manufacturer's civil and criminal liability ceases and the warranty is automatically invalidated in following cases:

- 1) if the user does not observe the essential environmental requirements given in the "warnings" section in the operation and maintenance manual supplied with the equipment and available on request at any time;
- 2) if assembly, addition re-calibration, adjustment and repair operations are not performed exclusively by "Castellini authorized" technical personnel with a valid licence;
- 3) if other medical devices and/or accessories not envisaged by Castellini S.p.A. or not meeting the compatibility specifications laid down by Castellini S.p.A. are connected to "Castellini" products;
- 4) if unauthorised modifications, tampering or inappropriate maintenance operations are performed or if non-original spare parts and/or components are used;
- 5) if the appliance is not used in accordance with the operating instructions (as indicated in the operation and maintenance manual) and for its intended purpose;
- 6) if the electrical, water and compressed air systems, the water outlet system and the suction system (if any) are not set up in accordance with the conditions given in the operations and maintenance manual (see "environment set-up" section and 1:1 scale installation plan drawing) and in compliance with legislation in the country of use;
- 7) if regular scheduled maintenance procedures are not carried out or any of the requirements of the operation and maintenance manual are not met.

We also stress that when the equipment is sold as new failure to observe the system specifications laid down by CASTELLINI S.p.A. or attributing to the devices performance and/or compatibility data that differ from those stated by CASTELLINI S.p.A. will release CASTELLINI S.p.A. of all responsibility regarding the CE marking on the product.

The warranty does not cover guards, glass parts, ceramic parts, enamelled parts, light bulbs, warning lamps, switches, upholstery, electric cables, tubes in general.

B) Equipments of other brands will be covered by the warranty issued by the original manufacturer. In any case CASTELLINI does not assume any responsibility regarding the warranty.



PERIODIC CHECK

form n° 1 - 1 year

This form, duly compiled, stamped and signed by an Authorized Castellini Technician, must remain permanently affixed to manual as proof that the periodic check has been performed and must be shown on request to the Supervisory Authorities

DENTAL UNIT

mod. _____

serial n° _____

CHAIR

mod. _____

serial n° _____

Date

Stamp and signature of Authorized Castellini Technician

License expiry date _____

Mod. Cast. U.T.008-E/1 (inglese)



PERIODIC CHECK

form n° 1 - 1 year

This form must be taken by the Authorized Castellini Technician

DENTAL UNIT

mod. _____

serial n° _____

CHAIR

mod. _____

serial n° _____

Date

Stamp and signature of Authorized Castellini Technician

License expiry date _____

Mod. Cast. U.T.008-E/1 (inglese)



SANITATION AND CLEANING

- Cleaning of lamp reflector and glass
- Surface cleaning of dental unit and chair (with STER 1 PLUS)
- Cleaning of surgical suction system (with STER 3 PLUS)
- Sterilisation of HPA filter cartridge (if present)
- Activation of Time Flushing System/Autosteril System
- Cleaning and stability control of the foot pedal basement

LUBRICATION

- Lubrication turbine (daily oil)
- Lubrication of micromotor handpiece
- Lubrication of O-ring of quick coupling of turbine (S1)
- Lubrication of O-ring of quick coupling of micromotor (S1)

CHECKS ON SAFETY**PROTECTION DEVICES**

- Check on chair descent safety stop
- Check on chair backrest safety stop
- Check on functioning of main switch
- Check on water/spray safety valve
- Check on connections and protective sheating of power cable
- Check on air/water supply connections

FUNCTIONAL/DIAGNOSTIC CHECKS

- Check on dental unit functions
- Check on Chair functions/Programming system
- Check on instrument functions
- Check on turbine supply pressure
- Check on syringe supply pressure (air/water)
- Check on Time Flushing/Autosteril system
- Check on supply system
- Check on system of separate supply/physiological solution
- Check on cup/cuspidor timing
- Check on suction system/Suction Stop

RENEWED INSTRUCTIONS TO THE USER AND ALL ASSISTANT PERSONNEL IN REGARD TO THE PROTOCOL FOR HYGIENE AND MAINTENANCE OF THE DENTAL UNIT

Date _____

Stamp and signature of Authorised Castellini Technician

License expiry
date _____**SANITATION AND CLEANING**

- Cleaning of lamp reflector and glass
- Surface cleaning of dental unit and chair (with STER 1 PLUS)
- Cleaning of surgical suction system (with STER 3 PLUS)
- Sterilisation of HPA filter cartridge (if present)
- Activation of Time Flushing System/Autosteril System
- Cleaning and stability control of the foot pedal basement

LUBRICATION

- Lubrication turbine (daily oil)
- Lubrication of micromotor handpiece
- Lubrication of O-ring of quick coupling of turbine (S1)
- Lubrication of O-ring of quick coupling of micromotor (S1)

CHECKS ON SAFETY**PROTECTION DEVICES**

- Check on chair descent safety stop
- Check on chair backrest safety stop
- Check on functioning of main switch
- Check on water/spray safety valve
- Check on connections and protective sheating of power cable
- Check on air/water supply connections

FUNCTIONAL/DIAGNOSTIC CHECKS

- Check on dental unit functions
- Check on Chair functions/Programming system
- Check on instrument functions
- Check on turbine supply pressure
- Check on syringe supply pressure (air/water)
- Check on Time Flushing/Autosteril system
- Check on supply system
- Check on system of separate supply/physiological solution
- Check on cup/cuspidor timing
- Check on suction system/Suction Stop

RENEWED INSTRUCTIONS TO THE USER AND ALL ASSISTANT PERSONNEL IN REGARD TO THE PROTOCOL FOR HYGIENE AND MAINTENANCE OF THE DENTAL UNIT

Date _____

Stamp and signature of Authorised Castellini Technician

License expiry
date _____

CASTELLINI[®] S.p.A.



PERIODIC CHECK

form n° 2 - 2 years

This form, duly compiled, stamped and signed by an Authorized Castellini Technician, must remain permanently affixed to manual as proof that the periodic check has been performed and must be shown on request to the Supervisory Authorities

DENTAL UNIT

mod. _____

serial n° _____

CHAIR

mod. _____

serial n° _____

Date

Stamp and signature of Authorized Castellini Technician

License expiry date _____

Mod. Cast. U.T008-E2 (inglese)



CASTELLINI[®] S.p.A.



PERIODIC CHECK

form n° 2 - 2 years

This form must be taken by the Authorized Castellini Technician

DENTAL UNIT

mod. _____

serial n° _____

CHAIR

mod. _____

serial n° _____

Date

Stamp and signature of Authorized Castellini Technician

License expiry date _____

Mod. Cast. U.T008-E2 (inglese)



SANITATION AND CLEANING

- Cleaning of lamp reflector and glass
- Surface cleaning of dental unit and chair (with STER 1 PLUS)
- Cleaning of surgical suction system (with STER 3 PLUS)
- Activation of Time Flushing System/Autosteril System
- Sterilisation of HPA filter cartridge (if present)
- Cleaning of Amalgam separator (if present)
- Cleaning of water filter (50µ - 25µ)
- Condensate drainage of general main air filter
- Cleaning and stability control of the foot pedal basement

LUBRICATION

- Lubrication turbine (daily oil)
- Lubrication of micromotor handpiece
- Lubrication of O-ring of quick coupling of turbine (S1)
- Lubrication of O-ring of quick coupling of micromotor (S1)

CHECKS ON SAFETY**PROTECTION DEVICES**

- Check on chair descent safety stop
- Check on chair backrest safety stop
- Check on functioning of main switch
- Check on water/spray safety valve
- Check on connections and protective sheathing of power cable
- Check on air/water supply connections
- Check on anchorage of casing/protections of chair and dental unit

FUNCTIONAL/DIAGNOSTIC CHECKS

- Check on dental unit functions
- Check on Chair functions/Programming system
- Check on instrument functions
- Check on turbine supply pressure
- Check on syringe supply pressure (air/water)
- Check on Time Flushing/Autosteril system
- Check on supply system
- Check on system of separate supply/physiological solution
- Check on cup/cuspidor timing
- Check on suction system - Suction Stop

RENEWED INSTRUCTIONS TO THE USER AND ALL ASSISTANT PERSONNEL IN REGARD TO THE PROTOCOL FOR HYGIENE AND MAINTENANCE OF THE DENTAL UNIT

Date _____

Stamp and signature of Authorised Castellini Technician

License expiry

date _____

SANITATION AND CLEANING

- Cleaning of lamp reflector and glass
- Surface cleaning of dental unit and chair (with STER 1 PLUS)
- Cleaning of surgical suction system (with STER 3 PLUS)
- Sterilisation of HPA filter cartridge (if present)
- Activation of Time Flushing System/Autosteril System
- Cleaning of Amalgam separator (if present)
- Cleaning of water filter (50µ - 25µ)
- Condensate drainage of general main air filter
- Cleaning and stability control of the foot pedal basement

LUBRICATION

- Lubrication turbine (daily oil)
- Lubrication of micromotor handpiece
- Lubrication of O-ring of quick coupling of turbine (S1)
- Lubrication of O-ring of quick coupling of micromotor (S1)

CHECKS ON SAFETY**PROTECTION DEVICES**

- Check on chair descent safety stop
- Check on chair backrest safety stop
- Check on functioning of main switch
- Check on water/spray safety valve
- Check on connections and protective sheathing of power cable
- Check on air/water supply connections
- Check on anchorage of casing/protections of chair and dental unit

FUNCTIONAL/DIAGNOSTIC CHECKS

- Check on dental unit functions
- Check on Chair functions/Programming system
- Check on instrument functions
- Check on turbine supply pressure
- Check on syringe supply pressure (air/water)
- Check on Time Flushing/Autosteril system
- Check on supply system
- Check on system of separate supply/physiological solution
- Check on cup/cuspidor timing
- Check on suction system - Suction Stop

RENEWED INSTRUCTIONS TO THE USER AND ALL ASSISTANT PERSONNEL IN REGARD TO THE PROTOCOL FOR HYGIENE AND MAINTENANCE OF THE DENTAL UNIT

Date _____

Stamp and signature of Authorised Castellini Technician

License expiry

date _____

CASTELLINI[®] S.p.A.



PERIODIC CHECK

form n° 3 – 3 years

This form, duly compiled, stamped and signed by an Authorized Castellini Technician, must remain permanently affixed to manual as proof that the periodic check has been performed and must be shown on request to the Supervisory Authorities

The Manufacturer notes that Turbodrills must undergo compulsory general overhaul; for this purpose they must be sent to the main office of Castellini S.p.A. via Saliceto, 22 40013 Castel Maggiore Bologna

DENTAL UNIT

mod. _____

serial n° _____

CHAIR

mod. _____

serial n° _____

Date _____

Stamp and signature of Authorized Castellini Technician _____

License expiry date _____

Mod. Cast. U.T.008-E/3 (inglese)



CASTELLINI[®] S.p.A.



PERIODIC CHECK

form n° 3 – 3 years

This form must be taken by the Authorized Castellini Technician

The Manufacturer notes that Turbodrills must undergo compulsory general overhaul; for this purpose they must be sent to the main office of Castellini S.p.A. via Saliceto, 22 40013 Castel Maggiore Bologna

DENTAL UNIT

mod. _____

serial n° _____

CHAIR

mod. _____

serial n° _____

Date _____

Stamp and signature of Authorized Castellini Technician _____

License expiry date _____

Mod. Cast. U.T.008-E/3 (inglese)



SANITATION AND CLEANING

- Cleaning of lamp reflector and glass
- Surface cleaning of dental unit and chair (with STER 1 PLUS)
- Cleaning of surgical suction system (with STER 3 PLUS)
- Activation of Time Flushing System/Autosteril System
- Cleaning and stability control of the foot pedal basement

REPLACEMENT OF PARTS

- Replacement of water filter filtering element (50µ - 25µ)
- Replacement of general air filter filtering element
- Replacement of suction filter
- Sterilisation of HPA filter cartridge (if present)
- Check/lubrication or replacement of O-ring of quick coupling of turbine (S1)
- Check/lubrication or replacement of O-ring of quick coupling of micromotor (S1)

LUBRICATION

- Lubrication turbine (daily oil)
- Lubrication of micromotor handpiece

CHECKS ON SAFETY**PROTECTION DEVICES**

- Check on chair descent safety stop
- Check on chair backrest safety stop
- Check on functioning of main switch
- Check on water/spray safety valve
- Check on connections and protective sheathing of power cable
- Check on air/water supply connections

SANITATION AND CLEANING

- Cleaning of lamp reflector and glass
- Surface cleaning of dental unit and chair (with STER 1 PLUS)
- Cleaning of surgical suction system (with STER 3 PLUS)
- Activation of Time Flushing System/Autosteril System
- Cleaning and stability control of the foot pedal basement

REPLACEMENT OF PARTS

- Replacement of water filter filtering element (50µ - 25µ)
- Replacement of general air filter filtering element
- Replacement of suction filter
- Sterilisation of HPA filter cartridge (if present)
- Check/lubrication or replacement of O-ring of quick coupling of turbine (S1)
- Check/lubrication or replacement of O-ring of quick coupling of micromotor (S1)

LUBRICATION

- Lubrication turbine (daily oil)
- Lubrication of micromotor handpiece

CHECKS ON SAFETY**PROTECTION DEVICES**

- Check on chair descent safety stop
- Check on chair backrest safety stop
- Check on functioning of main switch
- Check on water/spray safety valve
- Check on connections and protective sheathing of power cable
- Check on air/water supply connections

MECHANICAL DEVICES

- Check on balance of dental unit articulated arm
- Check on balance of lamp articulated arm
- Check on rotation/articulated racket of dental unit and lamp arms
- Check on shifting/articulation of headrest

FUNCTIONAL/DIAGNOSTIC CHECKS

- Check on dental unit functions
- Check on Chair functions/Programming system
- Check on instrument functions
- Check on turbine supply pressure
- Check on syringe supply pressure (air/water)
- Check on Time Flushing/Autosteril system
- Check on supply system
- Check on system of separate supply/physiological solution
- Check on amalgam separator device (if present)
- Check on suction system - Suction stop

RENEWED INSTRUCTIONS TO THE USER AND ALL ASSISTANT PERSONNEL IN REGARD TO THE PROTOCOL FOR HYGIENE AND MAINTENANCE OF THE DENTAL UNIT

Date _____

Stamp and signature of Authorised Castellini Technician

License expiry date _____

MECHANICAL DEVICES

- Check on balance of dental unit articulated arm
- Check on balance of lamp articulated arm
- Check on rotation/articulated racket of dental unit and lamp arms
- Check on shifting/articulation of headrest

FUNCTIONAL/DIAGNOSTIC CHECKS

- Check on dental unit functions
- Check on Chair functions/Programming system
- Check on instrument functions
- Check on turbine supply pressure
- Check on syringe supply pressure (air/water)
- Check on Time Flushing/Autosteril system
- Check on supply system
- Check on system of separate supply/physiological solution
- Check on amalgam separator device (if present)
- Check on suction system - Suction stop

RENEWED INSTRUCTIONS TO THE USER AND ALL ASSISTANT PERSONNEL IN REGARD TO THE PROTOCOL FOR HYGIENE AND MAINTENANCE OF THE DENTAL UNIT

Date _____

Stamp and signature of Authorised Castellini Technician

License expiry date _____



PERIODIC CHECK

form n° 4 – 4 years

This form, duly compiled, stamped and signed by an Authorized Castellini Technician, must remain permanently affixed to manual as proof that the periodic check has been performed and must be shown on request to the Supervisory Authorities

DENTAL UNIT

mod. _____

serial n° _____

CHAIR

mod. _____

serial n° _____

Date

Stamp and signature of Authorized Castellini Technician

License expiry date _____

Mod. Cast. U.T.008-E/4 (inglese)



PERIODIC CHECK

form n° 4 – 4 years

This form must be taken by the Authorized Castellini Technician

DENTAL UNIT

mod. _____

serial n° _____

CHAIR

mod. _____

serial n° _____

Date

Stamp and signature of Authorized Castellini Technician

License expiry date _____



Mod. Cast. U.T.008-E/4 (inglese)

SANITATION AND CLEANING

- Cleaning of lamp reflector and glass
- Surface cleaning of dental unit and chair (with STER 1 PLUS)
- Cleaning of surgical suction system (with STER 3 PLUS)
- Activation of Time Flushing System/Autosteril System
- Cleaning and stability control of the foot pedal basement

REPLACEMENT OF PARTS

- Replacement of water filter filtering element (50µ - 25µ)
- Replacement of general air filter filtering element
- Replacement of suction filter
- Sterilisation of HPA filter cartridge (if present)
- Check/lubrication or replacement of O-ring of quick coupling of turbine (S1)
- Check/lubrication or replacement of O-ring of quick coupling of micromotor (S1)

LUBRICATION

- Lubrication turbine (daily oil)
- Lubrication of micromotor handpiece

CHECKS ON SAFETY**PROTECTION DEVICES**

- Check on chair descent safety stop
- Check on chair backrest safety stop
- Check on functioning of main switch
- Check on water/spray safety valve
- Check on connections and protective sheathing of power cable
- Check on air/water supply connections

SANITATION AND CLEANING

- Cleaning of lamp reflector and glass
- Surface cleaning of dental unit and chair (with STER 1 PLUS)
- Cleaning of surgical suction system (with STER 3 PLUS)
- Activation of Time Flushing System/Autosteril System
- Cleaning and stability control of the foot pedal basement

REPLACEMENT OF PARTS

- Replacement of water filter filtering element (50µ - 25µ)
- Replacement of general air filter filtering element
- Replacement of suction filter
- Sterilisation of HPA filter cartridge (if present)
- Check/lubrication or replacement of O-ring of quick coupling of turbine (S1)
- Check/lubrication or replacement of O-ring of quick coupling of micromotor (S1)

LUBRICATION

- Lubrication turbine (daily oil)
- Lubrication of micromotor handpiece

CHECKS ON SAFETY**PROTECTION DEVICES**

- Check on chair descent safety stop
- Check on chair backrest safety stop
- Check on functioning of main switch
- Check on water/spray safety valve
- Check on connections and protective sheathing of power cable
- Check on air/water supply connections

MECHANICAL DEVICES

- Check on balance of dental unit articulated arm
- Check on balance of lamp articulated arm
- Check on rotation/articulated racket of dental unit and lamp arms
- Check on shifting/articulation of headrest

FUNCTIONAL/DIAGNOSTIC CHECKS

- Check on dental unit functions
- Check on Chair functions/Programming system
- Check on instrument functions
- Check on turbine supply pressure
- Check on syringe supply pressure (air/water)
- Check on Time Flushing/Autosteril system
- Check on supply system
- Check on system of separate supply/physiological solution
- Check on amalgam separator device (if present)
- Check on suction system - Suction stop

RENEWED INSTRUCTIONS TO THE USER AND ALL ASSISTANT PERSONNEL IN REGARD TO THE PROTOCOL FOR HYGIENE AND MAINTENANCE OF THE DENTAL UNIT

Date _____

Stamp and signature of Authorised Castellini Technician

License expiry date _____

MECHANICAL DEVICES

- Check on balance of dental unit articulated arm
- Check on balance of lamp articulated arm
- Check on rotation/articulated racket of dental unit and lamp arms
- Check on shifting/articulation of headrest

FUNCTIONAL/DIAGNOSTIC CHECKS

- Check on dental unit functions
- Check on Chair functions/Programming system
- Check on instrument functions
- Check on turbine supply pressure
- Check on syringe supply pressure (air/water)
- Check on Time Flushing/Autosteril system
- Check on supply system
- Check on system of separate supply/physiological solution
- Check on amalgam separator device (if present)
- Check on suction system - Suction stop

RENEWED INSTRUCTIONS TO THE USER AND ALL ASSISTANT PERSONNEL IN REGARD TO THE PROTOCOL FOR HYGIENE AND MAINTENANCE OF THE DENTAL UNIT

Date _____

Stamp and signature of Authorised Castellini Technician

License expiry date _____



PERIODIC CHECK

form n° 5 – 5 years

This form, duly compiled, stamped and signed by an Authorized Castellini Technician, must remain permanently affixed to manual as proof that the periodic check has been performed and must be shown on request to the Supervisory Authorities

DENTAL UNIT

mod. _____

serial n° _____

CHAIR

mod. _____

serial n° _____

Date

Stamp and signature of Authorized Castellini Technician

License expiry date _____

Mod. Cast. U.T.008-E/5 (inglese)



PERIODIC CHECK

form n° 5 – 5 years

This form must be taken by the Authorized Castellini Technician

DENTAL UNIT

mod. _____

serial n° _____

CHAIR

mod. _____

serial n° _____

Date

Stamp and signature of Authorized Castellini Technician

License expiry date _____

Mod. Cast. U.T.008-E/5 (inglese)



SANITATION AND CLEANING

- Cleaning of lamp reflector and glass
- Surface cleaning of dental unit and chair (with STER 1 PLUS)
- Cleaning of surgical suction system (with STER 3 PLUS)
- Activation of Time Flushing System/Autosteril System
- Cleaning and stability control of the foot pedal basement

REPLACEMENT OF PARTS

- Replacement of water filter filtering element (50µ - 25µ)
- Replacement of general air filter filtering element
- Replacement of suction filter
- Sterilisation of HPA filter cartridge (if present)
- Check/lubrication or replacement of O-ring of quick coupling of turbine (S1)
- Check/lubrication or replacement of O-ring of quick coupling of micromotor (S1)

LUBRICATION

- Lubrication turbine (daily oil)
- Lubrication of micromotor handpiece

CHECKS ON SAFETY**PROTECTION DEVICES**

- Check on chair descent safety stop
- Check on chair backrest safety stop
- Check on functioning of main switch
- Check on water/spray safety valve
- Check on connections and protective sheathing of power cable
- Check on air/water supply connections

SANITATION AND CLEANING

- Cleaning of lamp reflector and glass
- Surface cleaning of dental unit and chair (with STER 1 PLUS)
- Cleaning of surgical suction system (with STER 3 PLUS)
- Activation of Time Flushing System/Autosteril System
- Cleaning and stability control of the foot pedal basement

REPLACEMENT OF PARTS

- Replacement of water filter filtering element (50µ - 25µ)
- Replacement of general air filter filtering element
- Replacement of suction filter
- Sterilisation of HPA filter cartridge (if present)
- Check/lubrication or replacement of O-ring of quick coupling of turbine (S1)
- Check/lubrication or replacement of O-ring of quick coupling of micromotor (S1)

LUBRICATION

- Lubrication turbine (daily oil)
- Lubrication of micromotor handpiece

CHECKS ON SAFETY**PROTECTION DEVICES**

- Check on chair descent safety stop
- Check on chair backrest safety stop
- Check on functioning of main switch
- Check on water/spray safety valve
- Check on connections and protective sheathing of power cable
- Check on air/water supply connections

MECHANICAL DEVICES

- Check on balance of dental unit articulated arm
- Check on balance of lamp articulated arm
- Check on rotation/articulated racket of dental unit and lamp arms
- Check on shifting/articulation of headrest

FUNCTIONAL/DIAGNOSTIC CHECKS

- Check on dental unit functions
- Check on Chair functions/Programming system
- Check on instrument functions
- Check on turbine supply pressure
- Check on syringe supply pressure (air/water)
- Check on Time Flushing/Autosteril system
- Check on supply system
- Check on system of separate supply/physiological solution
- Check on amalgam separator device (if present)
- Check on suction system - Suction stop

RENEWED INSTRUCTIONS TO THE USER AND ALL ASSISTANT PERSONNEL IN REGARD TO THE PROTOCOL FOR HYGIENE AND MAINTENANCE OF THE DENTAL UNIT

Date _____

Stamp and signature of Authorised Castellini Technician

License expiry date _____

MECHANICAL DEVICES

- Check on balance of dental unit articulated arm
- Check on balance of lamp articulated arm
- Check on rotation/articulated racket of dental unit and lamp arms
- Check on shifting/articulation of headrest

FUNCTIONAL/DIAGNOSTIC CHECKS

- Check on dental unit functions
- Check on Chair functions/Programming system
- Check on instrument functions
- Check on turbine supply pressure
- Check on syringe supply pressure (air/water)
- Check on Time Flushing/Autosteril system
- Check on supply system
- Check on system of separate supply/physiological solution
- Check on amalgam separator device (if present)
- Check on suction system - Suction stop

RENEWED INSTRUCTIONS TO THE USER AND ALL ASSISTANT PERSONNEL IN REGARD TO THE PROTOCOL FOR HYGIENE AND MAINTENANCE OF THE DENTAL UNIT

Date _____

Stamp and signature of Authorised Castellini Technician

License expiry date _____

CASTELLINI[®] S.p.A.



PERIODIC CHECK

form n° 6 – 6 years

This form, duly compiled, stamped and signed by an Authorized Castellini Technician, must remain permanently affixed to manual as proof that the periodic check has been performed and must be shown on request to the Supervisory Authorities

The Manufacturer notes that Turbodrills must undergo compulsory general overhaul; for this purpose they must be sent to the main office of Castellini S.p.A. via Saliceto, 22 40013 Castel Maggiore Bologna

DENTAL UNIT

mod. _____

serial n° _____

CHAIR

mod. _____

serial n° _____

Date

Stamp and signature of Authorized Castellini Technician

License expiry date _____

Mod. Cast. U.T.008-E/6 (Inglese)

CASTELLINI[®] S.p.A.



PERIODIC CHECK

form n° 6 – 6 years

This form must be taken by the Authorized Castellini Technician

The Manufacturer notes that Turbodrills must undergo compulsory general overhaul; for this purpose they must be sent to the main office of Castellini S.p.A. via Saliceto, 22 40013 Castel Maggiore Bologna

DENTAL UNIT

mod. _____

serial n° _____

CHAIR

mod. _____

serial n° _____

Date

Stamp and signature of Authorized Castellini Technician

License expiry date _____

Mod. Cast. U.T.008-E/6 (inglese)

SANITATION AND CLEANING

- Cleaning of lamp reflector and glass
- Surface cleaning of dental unit and chair (with STER 1 PLUS)
- Cleaning of surgical suction system (with STER 3 PLUS)
- Activation of Time Flushing System/Autosteril System
- Cleaning and stability control of the foot pedal basement

REPLACEMENT OF PARTS

- Replacement of water filter filtering element (50µ - 25µ)
- Replacement of general air filter filtering element
- Replacement of suction filter
- Sterilisation of HPA filter cartridge (if present)
- Check/lubrication or replacement of O-ring of quick coupling of turbine (S1)
- Check/lubrication or replacement of O-ring of quick coupling of micromotor (S1)

LUBRICATION

- Lubrication turbine (daily oil)
- Lubrication of micromotor handpiece

CHECKS ON SAFETY**PROTECTION DEVICES**

- Check on chair descent safety stop
- Check on chair backrest safety stop
- Check on functioning of main switch
- Check on water/spray safety valve
- Check on connections and protective sheathing of power cable
- Check on air/water supply connections

SANITATION AND CLEANING

- Cleaning of lamp reflector and glass
- Surface cleaning of dental unit and chair (with STER 1 PLUS)
- Cleaning of surgical suction system (with STER 3 PLUS)
- Activation of Time Flushing System/Autosteril System
- Cleaning and stability control of the foot pedal basement

REPLACEMENT OF PARTS

- Replacement of water filter filtering element (50µ - 25µ)
- Replacement of general air filter filtering element
- Replacement of suction filter
- Sterilisation of HPA filter cartridge (if present)
- Check/lubrication or replacement of O-ring of quick coupling of turbine (S1)
- Check/lubrication or replacement of O-ring of quick coupling of micromotor (S1)

LUBRICATION

- Lubrication turbine (daily oil)
- Lubrication of micromotor handpiece

CHECKS ON SAFETY**PROTECTION DEVICES**

- Check on chair descent safety stop
- Check on chair backrest safety stop
- Check on functioning of main switch
- Check on water/spray safety valve
- Check on connections and protective sheathing of power cable
- Check on air/water supply connections

MECHANICAL DEVICES

- Check on balance of dental unit articulated arm
- Check on balance of lamp articulated arm
- Check on rotation/articulated racket of dental unit and lamp arms
- Check on shifting/articulation of headrest

FUNCTIONAL/DIAGNOSTIC CHECKS

- Check on dental unit functions
- Check on Chair functions/Programming system
- Check on instrument functions
- Check on turbine supply pressure
- Check on syringe supply pressure (air/water)
- Check on Time Flushing/Autosteril system
- Check on supply system
- Check on system of separate supply/physiological solution
- Check on amalgam separator device (if present)
- Check on suction system - Suction stop

RENEWED INSTRUCTIONS TO THE USER AND ALL ASSISTANT PERSONNEL IN REGARD TO THE PROTOCOL FOR HYGIENE AND MAINTENANCE OF THE DENTAL UNIT

Date _____

Stamp and signature of Authorised Castellini Technician

License expiry date _____

MECHANICAL DEVICES

- Check on balance of dental unit articulated arm
- Check on balance of lamp articulated arm
- Check on rotation/articulated racket of dental unit and lamp arms
- Check on shifting/articulation of headrest

FUNCTIONAL/DIAGNOSTIC CHECKS

- Check on dental unit functions
- Check on Chair functions/Programming system
- Check on instrument functions
- Check on turbine supply pressure
- Check on syringe supply pressure (air/water)
- Check on Time Flushing/Autosteril system
- Check on supply system
- Check on system of separate supply/physiological solution
- Check on amalgam separator device (if present)
- Check on suction system - Suction stop

RENEWED INSTRUCTIONS TO THE USER AND ALL ASSISTANT PERSONNEL IN REGARD TO THE PROTOCOL FOR HYGIENE AND MAINTENANCE OF THE DENTAL UNIT

Date _____

Stamp and signature of Authorised Castellini Technician

License expiry date _____



PERIODIC CHECK

form n° 7 - 7 years

This form, duly compiled, stamped and signed by an Authorized Castellini Technician, must remain permanently affixed to manual as proof that the periodic check has been performed and must be shown on request to the Supervisory Authorities

DENTAL UNIT

mod. _____

serial n° _____

CHAIR

mod. _____

serial n° _____

Date _____

Stamp and signature of Authorized Castellini Technician _____

License expiry date _____

Mod. Cast. U.T.008-E/7 (inglese)



PERIODIC CHECK

form n°. 7 - 7 years

This form must be taken by the Authorized Castellini Technician

DENTAL UNIT

mod. _____

serial n° _____

CHAIR

mod. _____

serial n° _____

Date _____

Stamp and signature of Authorized Castellini Technician _____

License expiry date _____

Mod. Cast. U.T.008-E/7 (inglese)

SANITATION AND CLEANING

- Cleaning of lamp reflector and glass
- Surface cleaning of dental unit and chair (with STER 1 PLUS)
- Cleaning of surgical suction system (with STER 3 PLUS)
- Activation of Time Flushing System/Autosteril System
- Cleaning and stability control of the foot pedal basement

REPLACEMENT OF PARTS

- Replacement of water filter filtering element (50µ - 25µ)
- Replacement of general air filter filtering element
- Replacement of suction filter
- Sterilisation of HPA filter cartridge (if present)
- Check/lubrication or replacement of O-ring of quick coupling of turbine (S1)
- Check/lubrication or replacement of O-ring of quick coupling of micromotor (S1)

LUBRICATION

- Lubrication turbine (daily oil)
- Lubrication of micromotor handpiece

CHECKS ON SAFETY**PROTECTION DEVICES**

- Check on chair descent safety stop
- Check on chair backrest safety stop
- Check on functioning of main switch
- Check on water/spray safety valve
- Check on connections and protective sheathing of power cable
- Check on air/water supply connections

SANITATION AND CLEANING

- Cleaning of lamp reflector and glass
- Surface cleaning of dental unit and chair (with STER 1 PLUS)
- Cleaning of surgical suction system (with STER 3 PLUS)
- Activation of Time Flushing System/Autosteril System
- Cleaning and stability control of the foot pedal basement

REPLACEMENT OF PARTS

- Replacement of water filter filtering element (50µ - 25µ)
- Replacement of general air filter filtering element
- Replacement of suction filter
- Sterilisation of HPA filter cartridge (if present)
- Check/lubrication or replacement of O-ring of quick coupling of turbine (S1)
- Check/lubrication or replacement of O-ring of quick coupling of micromotor (S1)

LUBRICATION

- Lubrication turbine (daily oil)
- Lubrication of micromotor handpiece

CHECKS ON SAFETY**PROTECTION DEVICES**

- Check on chair descent safety stop
- Check on chair backrest safety stop
- Check on functioning of main switch
- Check on water/spray safety valve
- Check on connections and protective sheathing of power cable
- Check on air/water supply connections

MECHANICAL DEVICES

- Check on balance of dental unit articulated arm
- Check on balance of lamp articulated arm
- Check on rotation/articulated racket of dental unit and lamp arms
- Check on shifting/articulation of headrest

FUNCTIONAL/DIAGNOSTIC CHECKS

- Check on dental unit functions
- Check on Chair functions/Programming system
- Check on instrument functions
- Check on turbine supply pressure
- Check on syringe supply pressure (air/water)
- Check on Time Flushing/Autosteril system
- Check on supply system
- Check on system of separate supply/physiological solution
- Check on amalgam separator device (if present)
- Check on suction system - Suction stop

RENEWED INSTRUCTIONS TO THE USER AND ALL ASSISTANT PERSONNEL IN REGARD TO THE PROTOCOL FOR HYGIENE AND MAINTENANCE OF THE DENTAL UNIT

Date _____

Stamp and signature of Authorised Castellini Technician

License expiry date _____

MECHANICAL DEVICES

- Check on balance of dental unit articulated arm
- Check on balance of lamp articulated arm
- Check on rotation/articulated racket of dental unit and lamp arms
- Check on shifting/articulation of headrest

FUNCTIONAL/DIAGNOSTIC CHECKS

- Check on dental unit functions
- Check on Chair functions/Programming system
- Check on instrument functions
- Check on turbine supply pressure
- Check on syringe supply pressure (air/water)
- Check on Time Flushing/Autosteril system
- Check on supply system
- Check on system of separate supply/physiological solution
- Check on amalgam separator device (if present)
- Check on suction system - Suction stop

RENEWED INSTRUCTIONS TO THE USER AND ALL ASSISTANT PERSONNEL IN REGARD TO THE PROTOCOL FOR HYGIENE AND MAINTENANCE OF THE DENTAL UNIT

Date _____

Stamp and signature of Authorised Castellini Technician

License expiry date _____



PERIODIC CHECK

form n° 8 - 8 years

This form, duly compiled, stamped and signed by an Authorized Castellini Technician, must remain permanently affixed to manual as proof that the periodic check has been performed and must be shown on request to the Supervisory Authorities

DENTAL UNIT

mod. _____

serial n° _____

CHAIR

mod. _____

serial n° _____

Date _____

Stamp and signature of Authorized Castellini Technician

License expiry date _____

Mod. Cast. U.T.008-E/8 (inglese)



PERIODIC CHECK

form n° 8 - 8 years

This form must be taken by the Authorized Castellini Technician

DENTAL UNIT

mod. _____

serial n° _____

CHAIR

mod. _____

serial n° _____

Date _____

Stamp and signature of Authorized Castellini Technician

License expiry date _____

Mod. Cast. U.T.008-E/8 (inglese)

SANITATION AND CLEANING

- Cleaning of lamp reflector and glass
- Surface cleaning of dental unit and chair (with STER 1 PLUS)
- Cleaning of surgical suction system (with STER 3 PLUS)
- Activation of Time Flushing System/Autosteril System
- Cleaning and stability control of the foot pedal basement

REPLACEMENT OF PARTS

- Replacement of water filter filtering element (50µ - 25µ)
- Replacement of general air filter filtering element
- Replacement of suction filter
- Sterilisation of HPA filter cartridge (if present)
- Check/lubrication or replacement of O-ring of quick coupling of turbine (S1)
- Check/lubrication or replacement of O-ring of quick coupling of micromotor (S1)

LUBRICATION

- Lubrication turbine (daily oil)
- Lubrication of micromotor handpiece

CHECKS ON SAFETY**PROTECTION DEVICES**

- Check on chair descent safety stop
- Check on chair backrest safety stop
- Check on functioning of main switch
- Check on water/spray safety valve
- Check on connections and protective sheathing of power cable
- Check on air/water supply connections

SANITATION AND CLEANING

- Cleaning of lamp reflector and glass
- Surface cleaning of dental unit and chair (with STER 1 PLUS)
- Cleaning of surgical suction system (with STER 3 PLUS)
- Activation of Time Flushing System/Autosteril System
- Cleaning and stability control of the foot pedal basement

REPLACEMENT OF PARTS

- Replacement of water filter filtering element (50µ - 25µ)
- Replacement of general air filter filtering element
- Replacement of suction filter
- Sterilisation of HPA filter cartridge (if present)
- Check/lubrication or replacement of O-ring of quick coupling of turbine (S1)
- Check/lubrication or replacement of O-ring of quick coupling of micromotor (S1)

LUBRICATION

- Lubrication turbine (daily oil)
- Lubrication of micromotor handpiece

CHECKS ON SAFETY**PROTECTION DEVICES**

- Check on chair descent safety stop
- Check on chair backrest safety stop
- Check on functioning of main switch
- Check on water/spray safety valve
- Check on connections and protective sheathing of power cable
- Check on air/water supply connections

MECHANICAL DEVICES

- Check on balance of dental unit articulated arm
- Check on balance of lamp articulated arm
- Check on rotation/articulated racket of dental unit and lamp arms
- Check on shifting/articulation of headrest

FUNCTIONAL/DIAGNOSTIC CHECKS

- Check on dental unit functions
- Check on Chair functions/Programming system
- Check on instrument functions
- Check on turbine supply pressure
- Check on syringe supply pressure (air/water)
- Check on Time Flushing/Autosteril system
- Check on supply system
- Check on system of separate supply/physiological solution
- Check on amalgam separator device (if present)
- Check on suction system - Suction stop

RENEWED INSTRUCTIONS TO THE USER AND ALL ASSISTANT PERSONNEL IN REGARD TO THE PROTOCOL FOR HYGIENE AND MAINTENANCE OF THE DENTAL UNIT

Date _____

Stamp and signature of Authorised Castellini Technician

License expiry date _____

MECHANICAL DEVICES

- Check on balance of dental unit articulated arm
- Check on balance of lamp articulated arm
- Check on rotation/articulated racket of dental unit and lamp arms
- Check on shifting/articulation of headrest

FUNCTIONAL/DIAGNOSTIC CHECKS

- Check on dental unit functions
- Check on Chair functions/Programming system
- Check on instrument functions
- Check on turbine supply pressure
- Check on syringe supply pressure (air/water)
- Check on Time Flushing/Autosteril system
- Check on supply system
- Check on system of separate supply/physiological solution
- Check on amalgam separator device (if present)
- Check on suction system - Suction stop

RENEWED INSTRUCTIONS TO THE USER AND ALL ASSISTANT PERSONNEL IN REGARD TO THE PROTOCOL FOR HYGIENE AND MAINTENANCE OF THE DENTAL UNIT

Date _____

Stamp and signature of Authorised Castellini Technician

License expiry date _____



PERIODIC CHECK form n° 9 - 9 years

This form, duly compiled, stamped and signed by an Authorized Castellini Technician, must remain permanently affixed to manual as proof that the periodic check has been performed and must be shown on request to the Supervisory Authorities

The Manufacturer notes that Turbodrills must undergo compulsory general overhaul; for this purpose they must be sent to the main office of Castellini S.p.A. via Saliceto, 22 40013 Castel Maggiore Bologna

DENTAL UNIT

mod. _____

serial n° _____

CHAIR

mod. _____

serial n° _____

Date

Stamp and signature of Authorized Castellini Technician

License expiry date _____

Mod. Cast. U.T.008-E/9 (inglese)



PERIODIC CHECK form n° 9 - 9 years

This form must be taken by the Authorized Castellini Technician

The Manufacturer notes that Turbodrills must undergo compulsory general overhaul; for this purpose they must be sent to the main office of Castellini S.p.A. via Saliceto, 22 40013 Castel Maggiore Bologna

DENTAL UNIT

mod. _____

serial n° _____

CHAIR

mod. _____

serial n° _____

Date

Stamp and signature of Authorized Castellini Technician

License expiry date _____



Mod. Cast. U.T.008-E/9 (inglese)

SANITATION AND CLEANING

- Cleaning of lamp reflector and glass
- Surface cleaning of dental unit and chair (with STER 1 PLUS)
- Cleaning of surgical suction system (with STER 3 PLUS)
- Activation of Time Flushing System/Autosteril System
- Cleaning and stability control of the foot pedal basement

REPLACEMENT OF PARTS

- Replacement of water filter filtering element (50µ - 25µ)
- Replacement of general air filter filtering element
- Replacement of suction filter
- Sterilisation of HPA filter cartridge (if present)
- Check/lubrication or replacement of O-ring of quick coupling of turbine (S1)
- Check/lubrication or replacement of O-ring of quick coupling of micromotor (S1)

LUBRICATION

- Lubrication turbine (daily oil)
- Lubrication of micromotor handpiece

CHECKS ON SAFETY**PROTECTION DEVICES**

- Check on chair descent safety stop
- Check on chair backrest safety stop
- Check on functioning of main switch
- Check on water/spray safety valve
- Check on connections and protective sheathing of power cable
- Check on air/water supply connections

SANITATION AND CLEANING

- Cleaning of lamp reflector and glass
- Surface cleaning of dental unit and chair (with STER 1 PLUS)
- Cleaning of surgical suction system (with STER 3 PLUS)
- Activation of Time Flushing System/Autosteril System
- Cleaning and stability control of the foot pedal basement

REPLACEMENT OF PARTS

- Replacement of water filter filtering element (50µ - 25µ)
- Replacement of general air filter filtering element
- Replacement of suction filter
- Sterilisation of HPA filter cartridge (if present)
- Check/lubrication or replacement of O-ring of quick coupling of turbine (S1)
- Check/lubrication or replacement of O-ring of quick coupling of micromotor (S1)

LUBRICATION

- Lubrication turbine (daily oil)
- Lubrication of micromotor handpiece

CHECKS ON SAFETY**PROTECTION DEVICES**

- Check on chair descent safety stop
- Check on chair backrest safety stop
- Check on functioning of main switch
- Check on water/spray safety valve
- Check on connections and protective sheathing of power cable
- Check on air/water supply connections

MECHANICAL DEVICES

- Check on balance of dental unit articulated arm
- Check on balance of lamp articulated arm
- Check on rotation/articulated racket of dental unit and lamp arms
- Check on shifting/articulation of headrest

FUNCTIONAL/DIAGNOSTIC CHECKS

- Check on dental unit functions
- Check on Chair functions/Programming system
- Check on instrument functions
- Check on turbine supply pressure
- Check on syringe supply pressure (air/water)
- Check on Time Flushing/Autosteril system
- Check on supply system
- Check on system of separate supply/physiological solution
- Check on amalgam separator device (if present)
- Check on suction system - Suction stop

RENEWED INSTRUCTIONS TO THE USER AND ALL ASSISTANT PERSONNEL IN REGARD TO THE PROTOCOL FOR HYGIENE AND MAINTENANCE OF THE DENTAL UNIT

Date _____

Stamp and signature of Authorised Castellini Technician

License expiry date _____

MECHANICAL DEVICES

- Check on balance of dental unit articulated arm
- Check on balance of lamp articulated arm
- Check on rotation/articulated racket of dental unit and lamp arms
- Check on shifting/articulation of headrest

FUNCTIONAL/DIAGNOSTIC CHECKS

- Check on dental unit functions
- Check on Chair functions/Programming system
- Check on instrument functions
- Check on turbine supply pressure
- Check on syringe supply pressure (air/water)
- Check on Time Flushing/Autosteril system
- Check on supply system
- Check on system of separate supply/physiological solution
- Check on amalgam separator device (if present)
- Check on suction system - Suction stop

RENEWED INSTRUCTIONS TO THE USER AND ALL ASSISTANT PERSONNEL IN REGARD TO THE PROTOCOL FOR HYGIENE AND MAINTENANCE OF THE DENTAL UNIT

Date _____

Stamp and signature of Authorised Castellini Technician

License expiry date _____



PERIODIC CHECK

form n° 10 – 10 years

This form, duly compiled, stamped and signed by an Authorized Castellini Technician, must remain permanently affixed to manual as proof that the periodic check has been performed and must be shown on request to the Supervisory Authorities

DENTAL UNIT

mod. _____

serial n° _____

CHAIR

mod. _____

serial n° _____

Date

Stamp and signature of Authorized Castellini Technician

License expiry date _____

Mod. Cast. U.T.008-E/10 (inglese)



PERIODIC CHECK

form n° 10 – 10 years

This form must be taken by the Authorized Castellini Technician

DENTAL UNIT

mod. _____

serial n° _____

CHAIR

mod. _____

serial n° _____

Date

Stamp and signature of Authorized Castellini Technician

License expiry date _____



Mod. Cast. U.T.008-E/10 (inglese)

SANITATION AND CLEANING

- Cleaning of lamp reflector and glass
- Surface cleaning of dental unit and chair (with STER 1 PLUS)
- Cleaning of surgical suction system (with STER 3 PLUS)
- Activation of Time Flushing System/Autosteril System
- Cleaning and stability control of the foot pedal basement

REPLACEMENT OF PARTS

- Replacement of water filter filtering element (50µ - 25µ)
- Replacement of general air filter filtering element
- Replacement of suction filter
- Sterilisation of HPA filter cartridge (if present)
- Check/lubrication or replacement of O-ring of quick coupling of turbine (S1)
- Check/lubrication or replacement of O-ring of quick coupling of micromotor (S1)

LUBRICATION

- Lubrication turbine (daily oil)
- Lubrication of micromotor handpiece

CHECKS ON SAFETY**PROTECTION DEVICES**

- Check on chair descent safety stop
- Check on chair backrest safety stop
- Check on functioning of main switch
- Check on water/spray safety valve
- Check on connections and protective sheathing of power cable
- Check on air/water supply connections

SANITATION AND CLEANING

- Cleaning of lamp reflector and glass
- Surface cleaning of dental unit and chair (with STER 1 PLUS)
- Cleaning of surgical suction system (with STER 3 PLUS)
- Activation of Time Flushing System/Autosteril System
- Cleaning and stability control of the foot pedal basement

REPLACEMENT OF PARTS

- Replacement of water filter filtering element (50µ - 25µ)
- Replacement of general air filter filtering element
- Replacement of suction filter
- Sterilisation of HPA filter cartridge (if present)
- Check/lubrication or replacement of O-ring of quick coupling of turbine (S1)
- Check/lubrication or replacement of O-ring of quick coupling of micromotor (S1)

LUBRICATION

- Lubrication turbine (daily oil)
- Lubrication of micromotor handpiece

CHECKS ON SAFETY**PROTECTION DEVICES**

- Check on chair descent safety stop
- Check on chair backrest safety stop
- Check on functioning of main switch
- Check on water/spray safety valve
- Check on connections and protective sheathing of power cable
- Check on air/water supply connections

MECHANICAL DEVICES

- Check on balance of dental unit articulated arm
- Check on balance of lamp articulated arm
- Check on rotation/articulated racket of dental unit and lamp arms
- Check on shifting/articulation of headrest

FUNCTIONAL/DIAGNOSTIC CHECKS

- Check on dental unit functions
- Check on Chair functions/Programming system
- Check on instrument functions
- Check on turbine supply pressure
- Check on syringe supply pressure (air/water)
- Check on Time Flushing/Autosteril system
- Check on supply system
- Check on system of separate supply/physiological solution
- Check on amalgam separator device (if present)
- Check on suction system - Suction stop

RENEWED INSTRUCTIONS TO THE USER AND ALL ASSISTANT PERSONNEL IN REGARD TO THE PROTOCOL FOR HYGIENE AND MAINTENANCE OF THE DENTAL UNIT

Date _____

Stamp and signature of Authorised Castellini Technician

License expiry date _____

MECHANICAL DEVICES

- Check on balance of dental unit articulated arm
- Check on balance of lamp articulated arm
- Check on rotation/articulated racket of dental unit and lamp arms
- Check on shifting/articulation of headrest

FUNCTIONAL/DIAGNOSTIC CHECKS

- Check on dental unit functions
- Check on Chair functions/Programming system
- Check on instrument functions
- Check on turbine supply pressure
- Check on syringe supply pressure (air/water)
- Check on Time Flushing/Autosteril system
- Check on supply system
- Check on system of separate supply/physiological solution
- Check on amalgam separator device (if present)
- Check on suction system - Suction stop

RENEWED INSTRUCTIONS TO THE USER AND ALL ASSISTANT PERSONNEL IN REGARD TO THE PROTOCOL FOR HYGIENE AND MAINTENANCE OF THE DENTAL UNIT

Date _____

Stamp and signature of Authorised Castellini Technician

License expiry date _____



Puma Evo

APPENDIX I – CERTIFICATIONS

EC Certificate



Full Quality Assurance

No. CE 01083

Issued to:

Castellini Spa
Sede Centrale
Via Saliceto, 22
Castel Maggiore
Bologna
40013
Italy

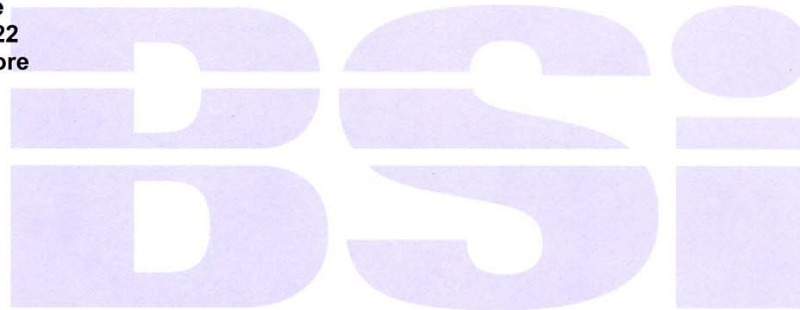

In respect of:

The design, development, manufacture and installation of dental equipment, x-ray generators and their supports and stands, electrosurgical units, and dental handpieces

on the basis of our examination under the requirements of Council Directive 93/42/EEC, Annex II, Section 3.2.

For and on behalf of the British Standards Institution, a Notified Body for the above Directive (Notified Body Number 0086):



Anne Boyd, Managing Director, BSI Product Services

First Issued: 11 Dec 1995

Date: 30 Sep 2005

Expiration Date: 10 Dec 2010

Page: 1 of 1

Conditions of Approval

Validity of this certificate is conditional on the quality system being maintained to the requirements of the Directive.

This approval excludes all products designed and/or manufactured by a third party on behalf of the company named on this certificate, unless specifically agreed with BSI.



CERTIFICATE OF REGISTRATION

Quality Management System

This is to certify that:

Castellini S.p.A
Sede Centrale
Via Saliceto 22
40013 Castel Maggiore
Bologna
Italy

Hold Certificate No: FM 51210

and operate a Quality Management System which complies with the requirements of BS EN ISO 9001:2000 for the following scope:

The design, manufacture, installation, maintenance and service of "own brand" dental equipment, X-ray units, electrosurgical units and dental handpieces. Provision of training and qualification for internal and external service engineers to install, maintain and service company products.

For and on behalf of BSI:

Certification Manager, Systems Assessment

Originally registered: 9 Jul 1999

Latest issue: 30 Dec 2003

Page: 1 of 1



003



This certificate remains the property of BSI and shall be returned immediately upon request. This certificate does not expire. To check its validity telephone: +44 (0)20 8996 9001 or visit www.bsi-global.com/ClientDirectory. Further clarifications regarding the scope of this certificate and the applicability of ISO 9001:2000 requirements may be obtained by consulting the organization.

*The British Standards Institution is incorporated by Royal Charter.
Group Headquarters: 389 Chiswick High Road, London W4 4AL, UK.*





CERTIFICATE OF REGISTRATION

Quality Management System

Castellini S.p.A

Sede Centrale
Via Saliceto 22
40013 Castel Maggiore
Bologna
Italy



Operate a Quality Management System
which complies with the requirements of
BS EN ISO 9001:2000
for the activities detailed in the scope of
registration.

Certificate No: **FM 51210**

Signed on behalf of BSI

Originally registered: **9 Jul 1999**



003



*This is not a legal document and cannot be used as such. This certificate does not expire.
To check its validity telephone +44 (0)20 8996 9001 or visit www.bsi-global.com/ClientDirectory
Further clarifications regarding the scope of this certificate and the applicability of ISO 9001:2000 requirements may be
obtained by consulting the organization. The British Standards Institution is incorporated by Royal Charter.
Group Headquarters: 389 Chiswick High Road, London W4 4AL, UK.*





CERTIFICATE OF REGISTRATION

Quality Management System

This is to certify that

Castellini S.p.A
Sede Centrale
Via Saliceto, 22
Castel Maggiore
Bologna
40013
Italy



Hold Certificate No: **MD 76089**

and operate a Quality Management System which complies with the requirements of **ISO 13485:2003** for the following scope:

The design, manufacture, installation, maintenance and service of "own brand" dental equipment, x-ray units, electrosurgical units and dental handpieces. Provision of training and qualification for internal and external service engineers to install, maintain and service company products to maintain compliance of products

For and on behalf of BSI:

Alastair Trivett, Managing Director, BSI Product Services – Global

First Issued: 23 Jan 2004

Date: 30 Oct 2006

Expiration Date: 22 Jan 2010



003

Page 1 of 1

This certificate remains the property of BSI and shall be returned immediately upon request.

The British Standards Institution is incorporated by Royal Charter.

Group Headquarters: 389 Chiswick High Road, London W4 4AL, UK.



PAGE WITHOUT TEXT